

Cooker hood	Data sheet / Datenblatt	Dunstabzugshaube
--------------------	--------------------------------	-------------------------

According to Regulation (EU) Nr. 65/2014 / Nach Verordnung (EU) Nr. 65/2014

Brand name <i>Warenzeichen</i>			
Welcome 1133100N			
Type / Model <i>Typ / Modell</i>			
Annual Energy Consumption <i>Jährliche Energieverbrauch</i>	AEC hood	28.6	kWh
Energy Efficiency Class <i>Energieeffizienzklasse</i>	D - A+++	B	
Fluid dynamic efficiency <i>Fluiddynamische Effizienz</i>	FDE hood	13.2	
Fluid dynamic efficiency class <i>Fluiddynamische Effizienzklasse</i>	G - A+++	D	
Lighting efficiency <i>Beleuchtungseffizienz</i>	LE hood	45.0	lux/W
Lighting Efficiency Class <i>Beleuchtungseffizienzklasse</i>	G - A+++	A	
Grease Filtering Efficiency <i>Fettabscheidegrad</i>	GFE hood	65.2	%
Grease Filtering Efficiency class <i>Effizienzklasse des Fettabscheidegrads</i>	G - A+++	D	
Minimum air flow in normal operation <i>Luftstrom bei min. Geschwindigkeit im Normalbetrieb</i>	m3/h	178.1	m3/h
Maximum air flow in normal operation <i>Luftstrom bei max. Geschwindigkeit im Normalbetrieb</i>	m3/h	316.0	m3/h
Air flow during operation on the intensive/ boost setting <i>Luftstrom im Betrieb auf der Intensiv- oder Schnelllaufstufe</i>	m3/h	/	m3/h
A- weighted airborne noise emissions in normal operation at minimum speed <i>A-bewertete Luftschallemission im Normalbetrieb bei min. Geschwindigkeit</i>	dB	51.0	dB (A) re 1pW
A- weighted airborne noise emissions in normal operation maximum speed <i>A-bewertete Luftschallemission im Normalbetrieb bei max. Geschwindigkeit</i>	dB	64.0	dB (A) re 1pW
A- weighted airborne noise emission in the intensive or boost speed <i>A-bewertete Luftschallemission in der Intensiv- oder Schnelllaufstufe</i>	dB	/	dB (A) re 1pW
Power consumption in off mode <i>Leistungsaufnahme im Aus-Zustand</i>	Po	0	W
Power consumption in standby mode <i>Leistungsaufnahme im Bereitschaftsmodus</i>	Ps	/	W

Additional Product Information compliant to commission regulation (EU) Nr. 66/2014 <i>Zusätzliche Produktinformationen gemäß Kommissionsverordnung (EU) Nr. 66/2014</i>			
Time increase factor <i>Zeitverlängerungsfaktor</i>	f	1.5	
Energy efficiency index <i>Energieeffizienzindex</i>	EEI hood	65.4	
Measured air flow rate at best efficiency point <i>Gemessener Luftvolumenstrom im Bestpunkt</i>	Q BEP	190.5	m3/h
Measured air pressure at the best efficiency point <i>Gemessener Luftdruck im Bestpunkt</i>	P BEP	123.8	Pa
Maximum air flow <i>Maximaler Luftstrom</i>	Q max	316.0	m3/h
Measured electric power input at best efficiency point <i>Gemessene elektr. Eingangsleistung im Bestpunkt</i>	W BEP	49.7	W
Nominal power of the lighting system <i>Nennleistung des Beleuchtungssystems</i>	WL	1.9	W
Average illumination of the lighting system on the cooking surface <i>Durchschnittl. Beleuchtungsstärke des Beleuchtungssystems auf der Kochoberfläche</i>	E middle	85.0	lux
<i>Bezeichnung der bei der Überprüfung der Übereinstimmung mit den vorstehenden Anforderungen angewandten Mess- und Berechnungsmethoden oder Bezugnahme darauf: EN61591, EN60704-2-13, EN50564</i>			

NEG-Novex Großhandelsgesellschaft für Elektro- und Haustechnik GmbH,
Chenover Str. 5, DE - 67117 Limburgerhof, Germany



Kopffreie Schräghaube Glasschirm schwarz, 60 cm

WELCOME1133100N

B

- + Energieeffizienzklasse B
- + Metallgehäuse mit Glasschirm
- + Breite: 60 cm
- + Schräge Bauform für mehr Kopffreiheit
- + 3 Leistungsstufen
- + LED-Beleuchtung
- + Abluft & Umluftbetrieb möglich

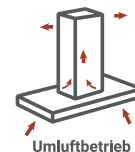
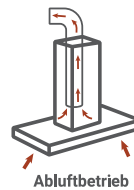
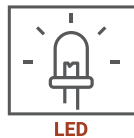
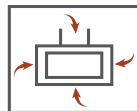

TECHNISCHE DATEN

Jährlicher Energieverbrauch (AEC _{hood})	29,4 kWh
Energieeffizienzklasse	B
Fluiddynamische Effizienz (FDE _{hood})	14,1
Fluiddynamische Effizienzklasse	D
Beleuchtungseffizienz (LE _{hood})	49,4 Lux / Watt
Beleuchtungseffizienzklasse	A
Fettabscheidegrad	69,1 %
Fettabscheideeffizienzklasse	D
Luftstrom bei minimaler / maximaler Geschwindigkeit im Normalbetrieb	197,7 – 339,2 m ³ /h
A-bewertete Luftschallemission bei minimaler / maximaler Geschwindigkeit im Normalbetrieb	51 – 63,5 dB (A)
Leistungsaufnahme im Aus-Zustand	0 Watt
Leistungsaufnahme im Bereitschaftszustand	–

AUSSTATTUNG

Steuerung	Drucktasten
Glasschirm	schwarz
Korpus	Stahlblech schwarz lackiert
Schacht	Stahlblech schwarz lackiert
Leistungsstufen	3
LED Beleuchtung max.	2 x 1,5 Watt
Rohranschluss (Durchmesser)	150 mm
Spannung / Frequenz	220 – 240 V / 50 Hz
Anschlusswert	68 Watt
Kabellänge	120 cm

ABMESSUNGEN

Gerätemaße (H x B x T) / Gewicht	68,1–101,1 x 59,5 x 29 cm / 8,2 kg
Maße mit Verpackung (H x B x T) / Gewicht	43 x 62 x 37 cm / 10,2 kg

ZUBEHÖR

EAN

Inkl. Metallfettfilter (auswaschbar) 1 x MIZ 33060	4260515332508
Nicht enthalten: Aktiv-Kohlefilter 2 x MIZ 0060 N	4260515337756
Nicht enthalten: Umluftweiche 1 x ULW 1	4260458247112

ARTIKELNUMMER

FARBE

EAN

WELCOME1133100N	schwarz	4262376913346
-----------------	---------	---------------



Geschirrspüler, vollintegriert EGSP1241 V

Beschreibung A I G E

Bei einer Menge von bis zu 6 Gedecken passt die Funktion "Halbe Beladung" den Wasserstromverbrauch automatisch an

Highlights

- ✓ Energieeffizienzklasse E
- ✓ 4 Programme
- ✓ Startzeitvorwahl
- ✓ Platz für 12 Gedecke
- ✓ inkl. AquaStop Schlauch



Abbildung kann vom Original abweichen

Technische Daten	
Geräteart	Geschirrspüler, vollintegriert
Steuerung	Elektroniktasten
Fassungsvermögen	12 Gedecke
Energieeffizienzklasse A (höchste Effizienz) bis G (geringste Effizienz) nach neuer EU Norm	E
jährlicher Energieverbrauch	92,00 kWh/Jahr
Energieverbrauch Standardprogramm	0,92 kW/h
Trocknungseffizienzklasse A (höchste Effizienz) bis G (geringste Effizienz)	A
jährlicher Wasserverbrauch	1100 Liter/Jahr
Wasserverbrauch Standardprogramm	11 Liter
Programmdauer Standardreinigungszyklus	230 Minuten
Geräuschemission	52 dB(A) re 1 pW
Luftschallemissionsklasse	D
Leistung	2100 Watt
Reinigungstemperaturen	45 / 50 / 60 / 65 °C
Leistungsaufnahme im Aus-Zustand	0,45 Watt
Leistungsaufnahme im unausgeschalteten Zustand	0,49 Watt
Angabe zum Gerät	Einbau
Energiesparfunktion	Ja
Ausstattung	
Bedienung	Elektroniktasten
Innenraum	Kunststoffbodenwanne
Heizelement	Verdeckt
Sprühebenen	2
Körbe	2
Tassenhalter	1
Besteckkorb	1
Programme	4 Stück: Intensiv, ECO, 90 Minuten, Schnell
Startzeitvorwahl	Ja - 3 / 6 / 9 / 12 Stunden
Funktion "Halbe Beladung"	Ja
Kindersicherung	Ja
Spülmittelmengeneinstellungsfunktion	Ja
höhenverstellbare Füße	2x vorne / 1x hinten
Überlaufschutz	Ja
Wasserenthärtungsfunktion	Ja
Klarspülmangelanzeige	Ja
Salzmangelanzeige	Ja
AquaStop Funktion	Ja
Logistik	
Geräteabmessungen (HxBxT)	81,50 - 86,50 x 59,80 x 55,00 cm
Verpackungsabmessungen (HxBxT)	89,00 x 64,50 x 64,50 cm
Nettogewicht	33,00 Kg
Bruttogewicht	40,00 Kg
Containermenge 40HQ	162 Stück
Garantie	2 Jahre
Artikelnummer	40112
EAN Nummer	5903867531838

Das Standardprogramm ist für die Reinigung von normal verschmutzten Geschirrs geeignet und ist in Bezug auf den kombinierten Energie - und Wasserverbrauch am effizientesten

Der angegebene jährliche Wasserverbrauch basiert auf der Grundlage von 100 Standardreinigungszyklen. Der tatsächliche Wasserverbrauch hängt von der Art der Nutzung des Geräts ab.

Der angegebene jährliche Energieverbrauch basiert auf der Grundlage von 100 Standardreinigungszyklen. Der tatsächliche Energieverbrauch hängt von der Art der Nutzung des Geräts ab.

Technische Zeichnungen

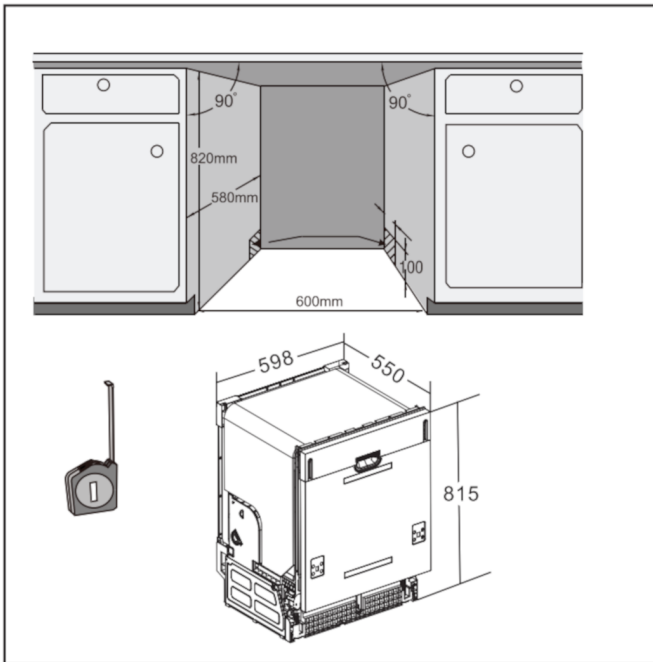

Produktdatenblatt

DELEGIERTE VERORDNUNG (EU) 2019/2017 DER KOMMISSION zur Energieverbrauchskennzeichnung von Haushaltsgeschirrspülern

Name oder Handelsmarke des Lieferanten: WELCOME

Anschrift des Lieferanten: -

Modellkennung: EGSP1241 V

Allgemeine Produktparameter:

Parameter	Wert	Parameter	Wert	
Nennkapazität ^(a) (ps)	12	Abmessungen in cm	Höhe	86
			Breite	60
			Tiefe	55
EEI ^(a)	55,9	Energieeffizienzklasse ^(a)	E	
Reinigungsleistungsindex ^(a)	1,125	Trocknungsleistungsindex ^(a)	1,065	
Energieverbrauch in kWh [pro Betriebszyklus] im eco-Programm bei Kaltwasseranschluss. Der tatsächliche Energieverbrauch hängt von der jeweiligen Nutzung des Geräts ab.	0,923	Wasserverbrauch in Litern [pro Betriebszyklus] im eco-Programm. Der tatsächliche Wasserverbrauch hängt von der jeweiligen Nutzung des Geräts und vom Härtegrad des Wassers ab.	11,0	
Programmdauer ^(a) (h:min)	3:50	Art	Einbaugerät	
Luftschallemissionen ^(a) (dB (A) re 1 pW)	52	Luftschallemissionsklasse ^(a)	D	
Aus-Zustand (W) (falls zutreffend)	0,49	Bereitschaftszustand (W) (falls zutreffend)	-	
Zeitvorwahl (W) (falls zutreffend)	1,00	Vernetzter Bereitschaftsbetrieb (W) (falls zutreffend)	-	

Mindestlaufzeit der vom Lieferanten angebotenen Garantie: 24 Monate

Weitere Angaben:

Weblink zur Website des Lieferanten, auf der die Informationen gemäß Anhang II Nummer 6 der Verordnung (EU) 2019/2022 der Kommission zu finden sind: -

^(a) für das eco-Programm.



Einbauherdset EHC-360E H

Beschreibung A

Der EHC- 360E H besticht durch leichte Bedienbarkeit.

Highlights

- ✓ Energieeffizienzklasse A
- ✓ Edelstahlblende
- ✓ Glaskeramikkochfeld
- ✓ 3 Backofen Funktionen
- ✓ Gehäusekühlung

UVP: 459,00 €



Abbildung kann vom Original abweichen

Technische Daten	
Geräteart	Einbauherdset
Bedienpanel	Edelstahlblende
Material Kochfeld	Glaskeramik
Energieeffizienzklasse A+++ (höchste Effizienz) bis D (geringste Effizienz)	A
Energieeffizienzindex	94,9
Energieverbrauch (konventionell)	0,74 kW/h
Nutzbare Volumen des Garraums	55 Liter
Anzahl Wärmequellen pro Garraum	1 (Elektro)
Größe des Gerätes	mittel: 35 l < Volumen < 65 l
Anzahl Kochfelder	4
Durchmesser Kochfeld vorne links	18,00 cm
Durchmesser Kochfeld vorne rechts	14,00 cm
Durchmesser Kochfeld hinten links	14,00 cm
Durchmesser Kochfeld hinten rechts	18,00 cm
Leistung Kochfeld vorne links	1800 Watt
Leistung Kochfeld vorne rechts	1200 Watt
Leistung Kochfeld hinten links	1200 Watt
Leistung Kochfeld hinten rechts	1800 Watt
Restwärmanzeige	ja
Funktionen Backofen	Oberhitze, Unterhitze, Ober- und Unterhitze
Geräuschemission	< 52 dB(A) re 1 pW
Maximale Leistung	8350 Watt
Spannung	220 - 240 Volt
Frequenz	50 Hz
Ausstattung	
Vollglasinnentüre	ja
Backofentür	schwarzes Glas
Backofentür Glasschichten	2
Gehäusekühlung	ja
Griff und Knöpfe	Aluminium
Fettpfanne	1
Grillrost	1
Logistik	
Geräteabmessungen Ofen (HxBxT)	59,50 x 59,50 x 50,00 cm
Gerätemaß Kochfeld (HxBxT)	5,00 x 58,00 x 51,00 cm
Verpackungsabmessungen Kochfeld (HxBxT)	14,00 x 63,50 x 57,00 cm
Verpackungsabmessungen Ofen (HxBxT)	65,00 x 66,00 x 57,70 cm
Nettogewicht Ofen	27,00 Kg
Bruttogewicht Ofen	30,00 Kg
Nettogewicht Kochfeld	8,00 Kg
Bruttogewicht Kochfeld	10,00 Kg
Containermenge	237 Stück
Garantie	2 Jahre
Artikelnummer	23366
EAN Nummer	5903867537601
UVP	459,00 €

Produktdatenblatt nach Verordnung (EU) VO 65/2014

Marke / Warenzeichen	Welcome
Modellkennung/Name	EHC-360E H
Energieeffizienzindex	94,9
Energieeffizienzklasse ¹	A
Energieverbrauch pro Zyklus im konventionellen Modus	0,74 kW/h
Energieverbrauch pro Zyklus im Umluft-Modus	-
Zahl der Garräume	-
Wärmequellen pro Garraum	1 (Elektro)
Volumen des Garraumes	55 Liter

¹ A+++ (höchste Effizienz) bis D (niedrigste Effizienz)

Produktdatenblatt nach Verordnung (EU) Nr. 66/2014

Marke / Warenzeichen	Welcome
Modellkennung/Name	Kochfeld zu EHC-360E H
Anzahl der Kochfelder	4
Heiztechnik	Strahlungstechnik
Ø Kochzone - hinten links	14,00 cm
Ø Kochzone - vorne links	18,00 cm
Ø Kochzone - hinten rechts	18,00 cm
Ø Kochzone - vorne rechts	14,00 cm
Ø Kochzone - mitte	-
Ovale Kochzone 1 (L x B)	-
Ovale Kochzone 2 (L x B)	-
Energieverbrauch Kochzone 1 je kg	183,5 Wh/kg
Energieverbrauch Kochzone 2 je kg	190,4 Wh/kg
Energieverbrauch Kochzone 3 je kg	196,4 Wh/kg
Energieverbrauch Kochzone 4 je kg	191,7 Wh/kg
Energieverbrauch Kochzone 5 je kg	-
Energieverbrauch der Kochmulde je kg	190,1 Wh/kg

XXXXXXXXXXXX serie: xxx



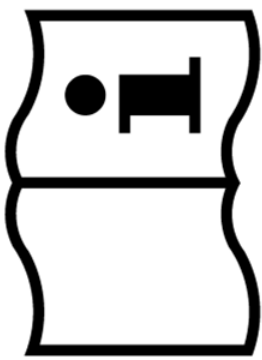
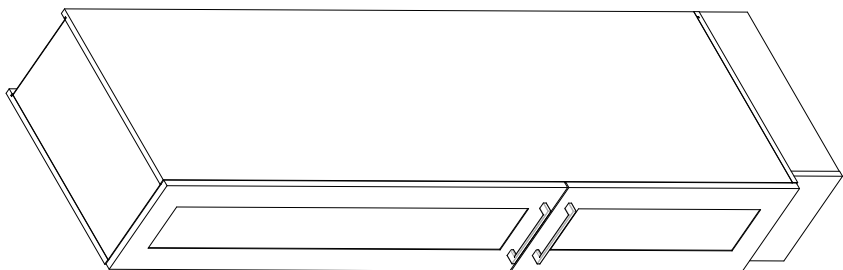
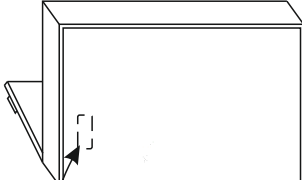

 Hergestellt für:

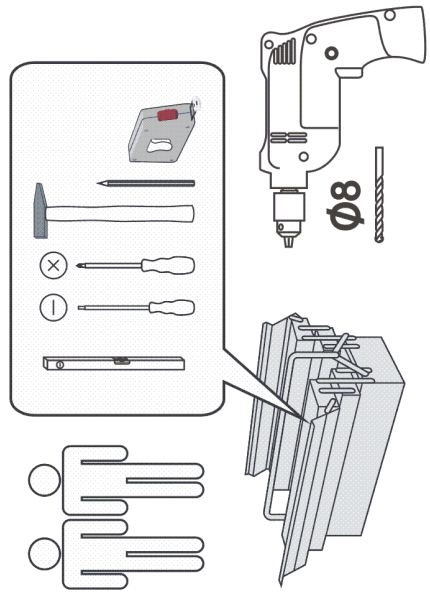
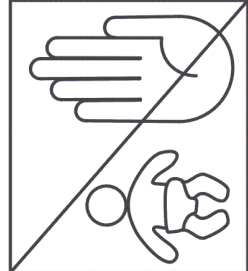
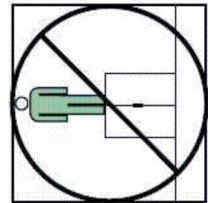
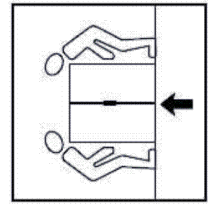
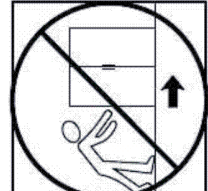
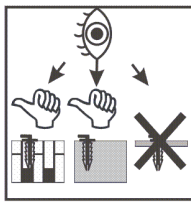
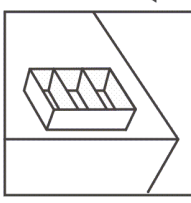
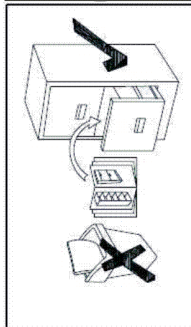
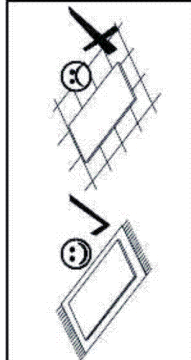

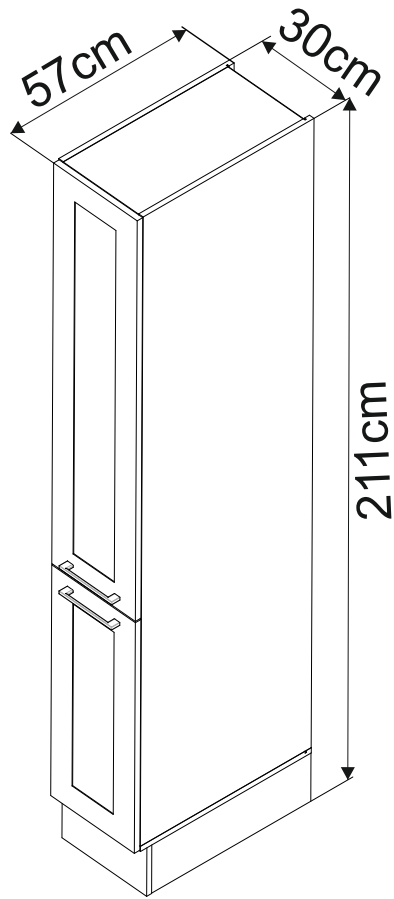
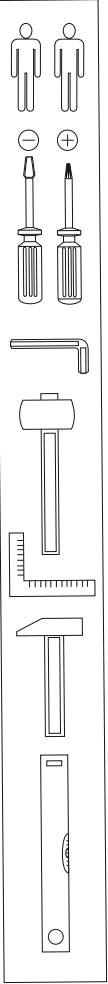
120 min

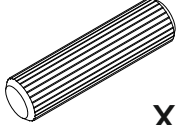
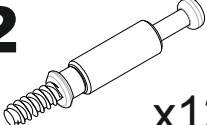
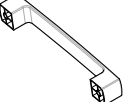
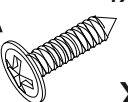
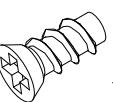

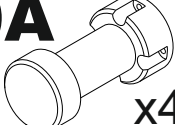
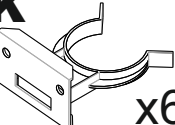
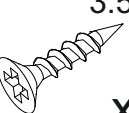
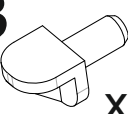

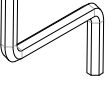
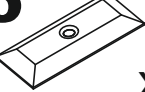
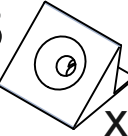
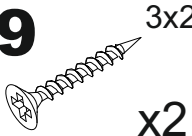
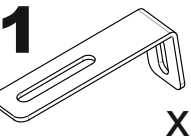
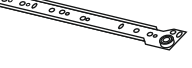
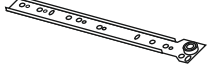
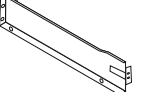
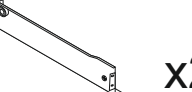
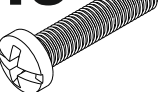
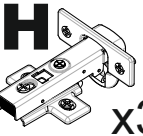
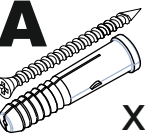
- | | | | | |
|---|---|---|--|---|
| 1

x12 | 2

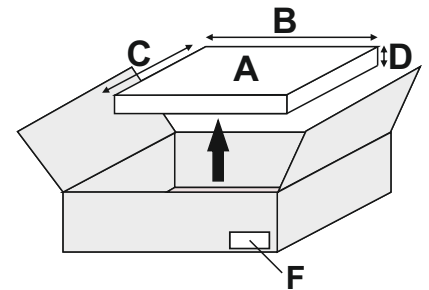
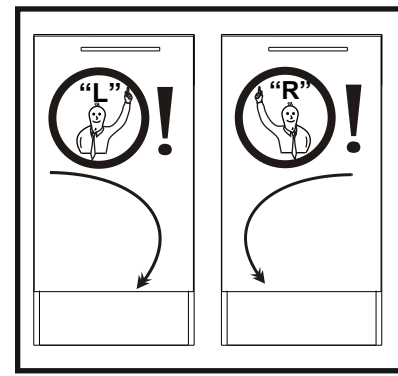
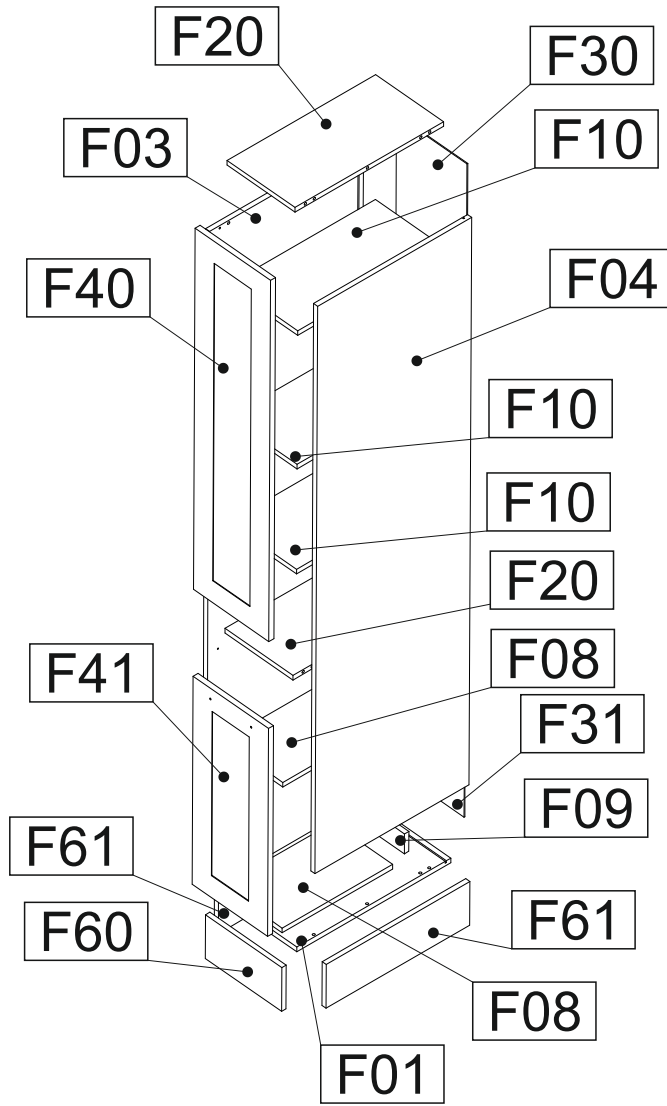
x12 | 3

x2 | 4A

4x16
x1 | 6

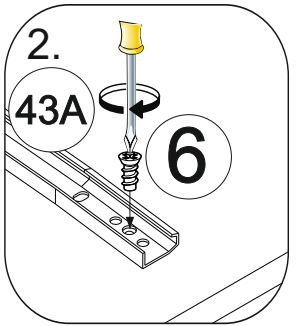
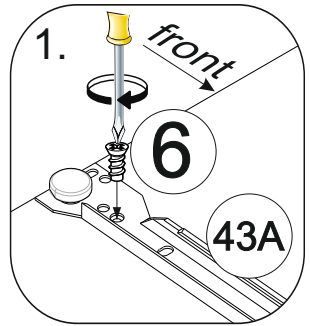
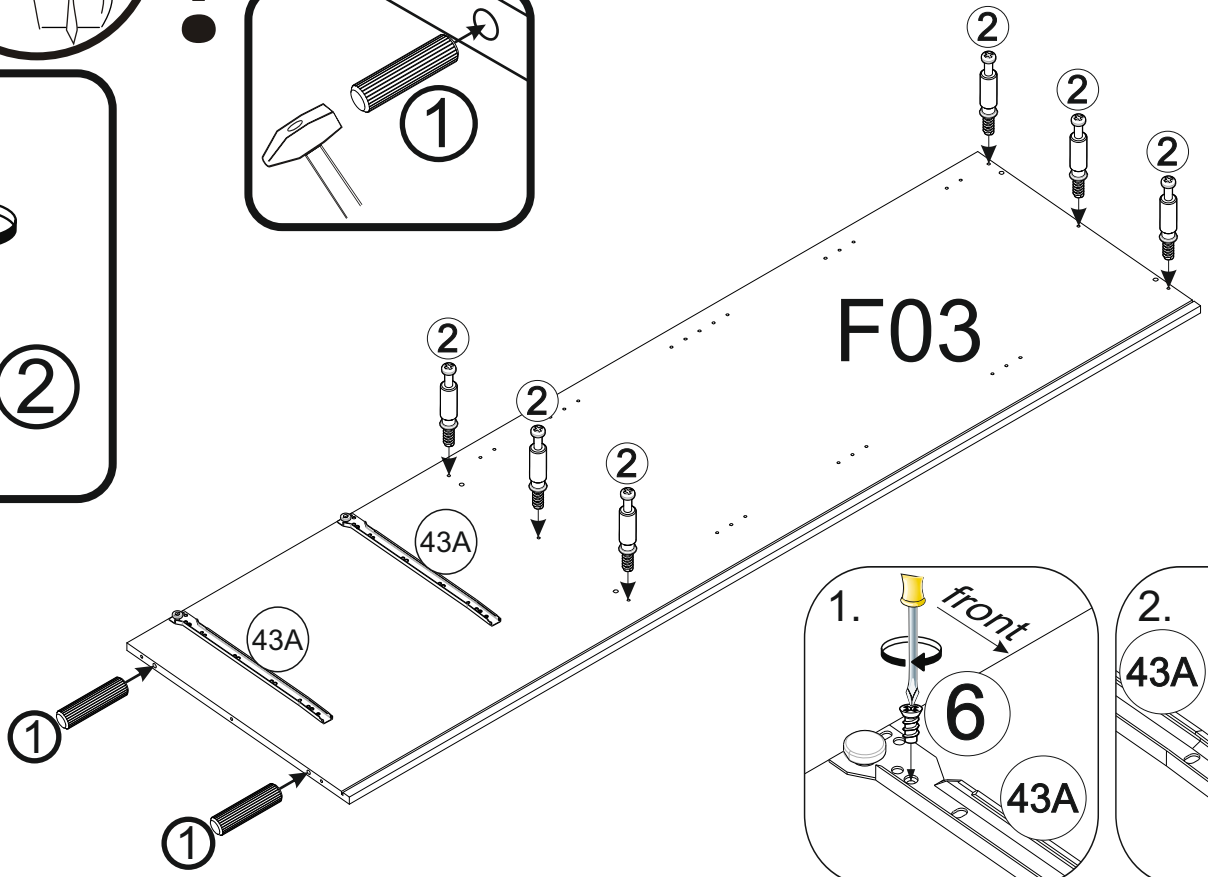
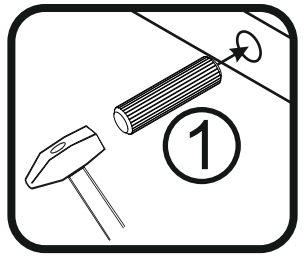
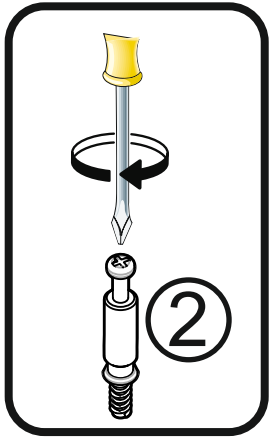
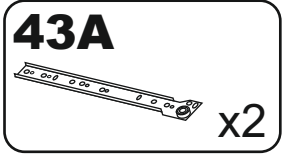
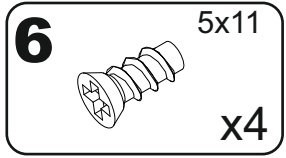
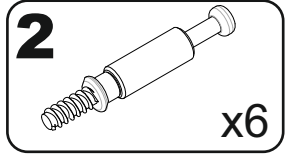
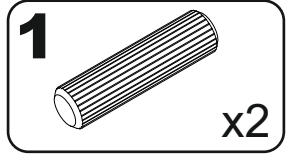
5x11
x38 |
| 9

ø15
x12 | 9A

x12 | 10A

x4 | 10K

x6 | 11

3.5x13
x28 |
| 13

x12 | 22

x6 | 22A

x6 | 26

x1 | 35

x3 |
| 38

x15 | 39

3x20
x21 | 41

x1 | 43A

x2 | 43B

x2 |
| 43C

x2 | 43D

x2 | 49

M4x22
x4 | 54H

x3 | 80A

x1 |





A	B_(mm)	C_(mm)	D_(mm)	E	F
F01	300	555	16	1	1 2
F03	1945	555	16	1	2 2
F04	1945	555	16	1	2 2
F08	398	236	16	2	1 2
F09	236	68	16	2	1 2
F10	267	525	16	3	1 2
F20	267	535	16	2	1 2
F30	1240	277	3	1	2 2
F31	707	277	3	1	2 2
F40	296	1238	18	1	1 2
F41	296	713	18	1	1 2
F60	300	150	16	1	1 2
F61	518	150	16	2	1 2

1



2

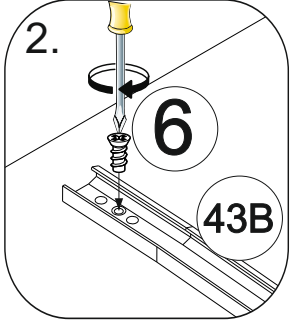
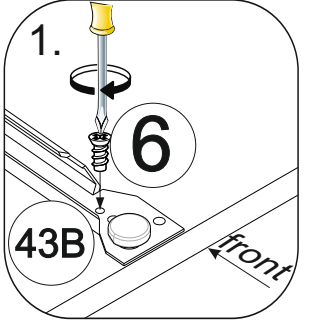
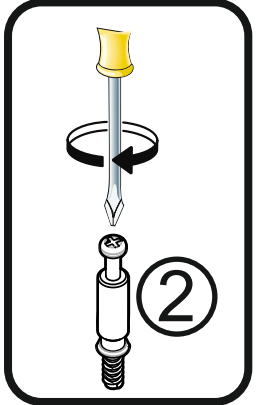
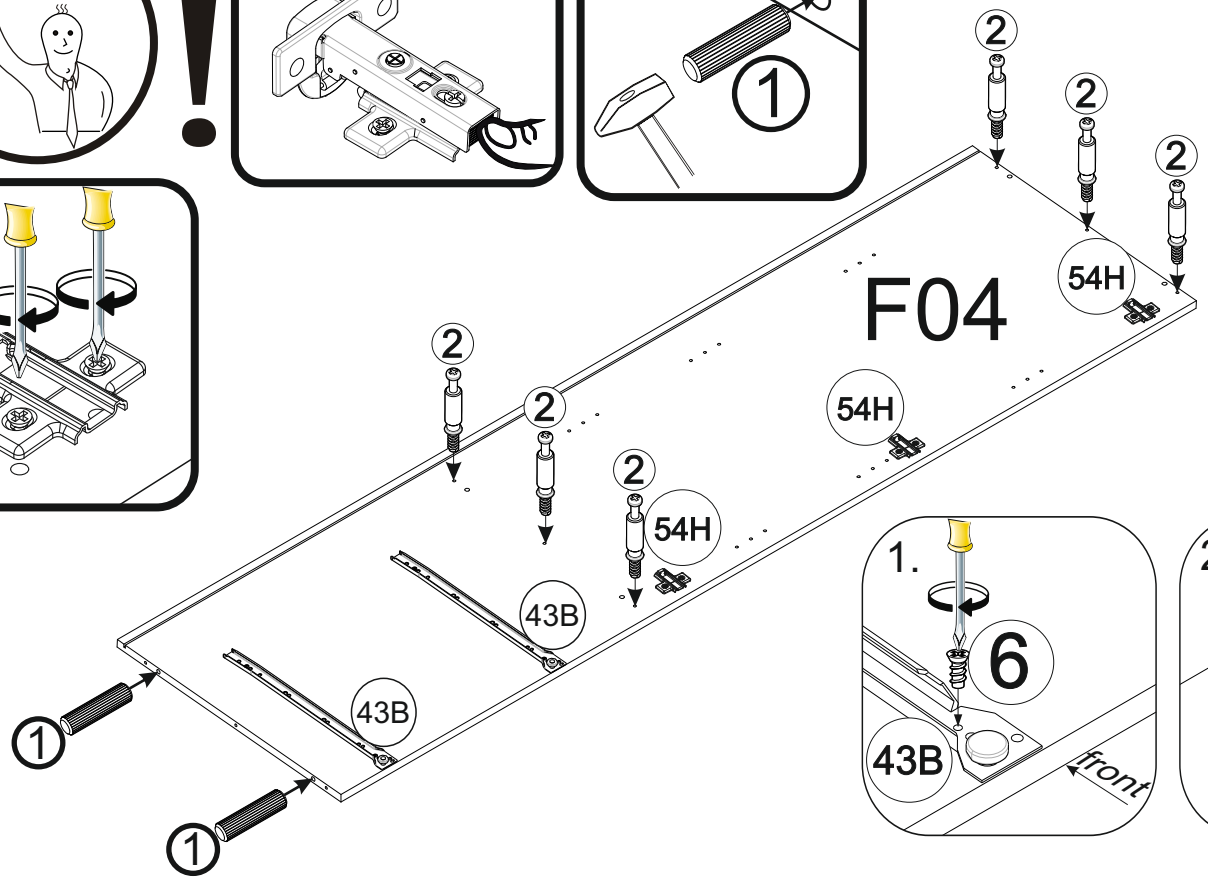
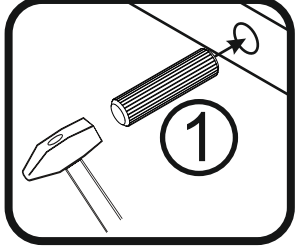
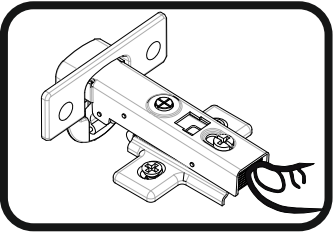
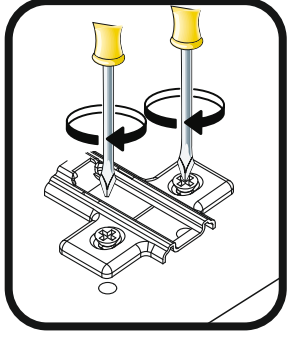
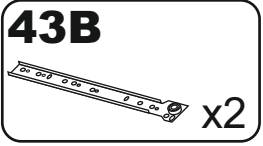
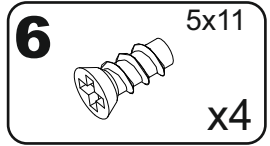
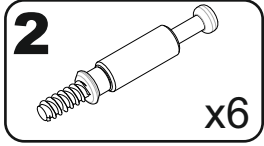
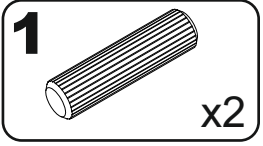

3

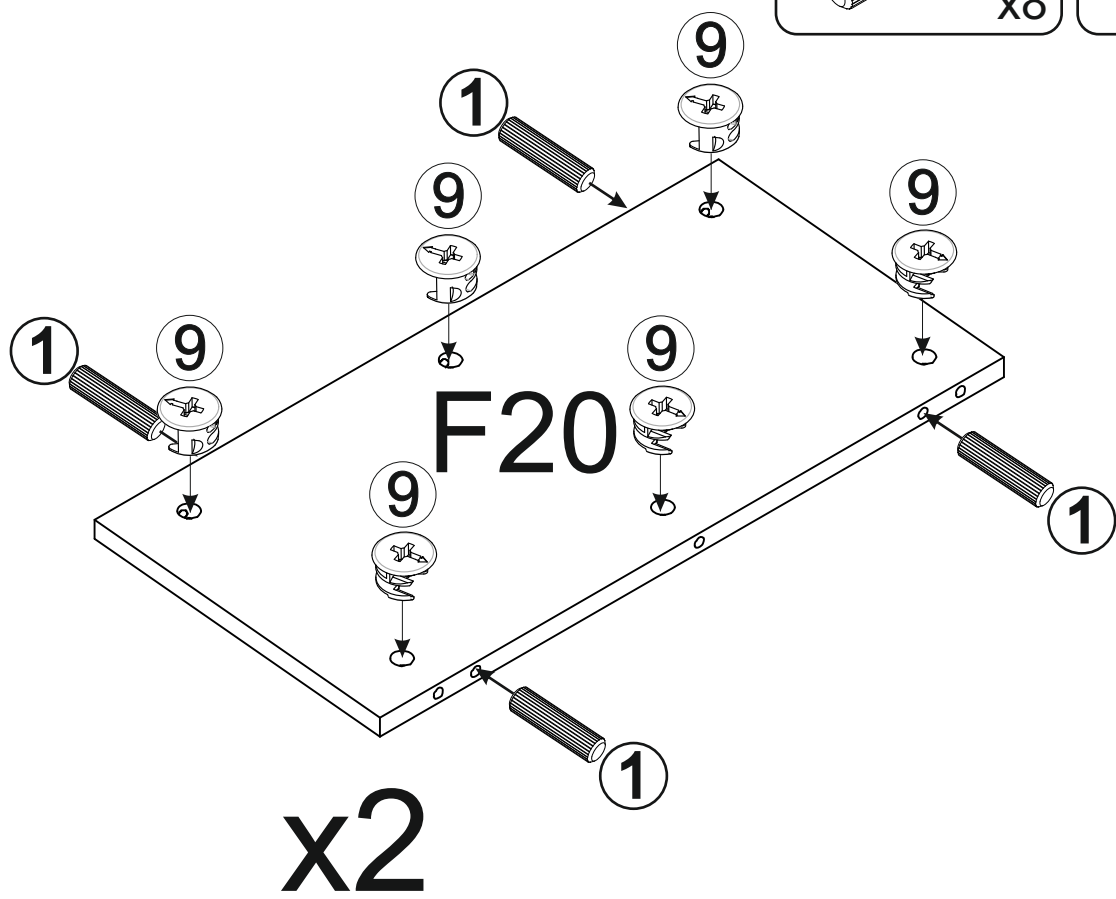

4

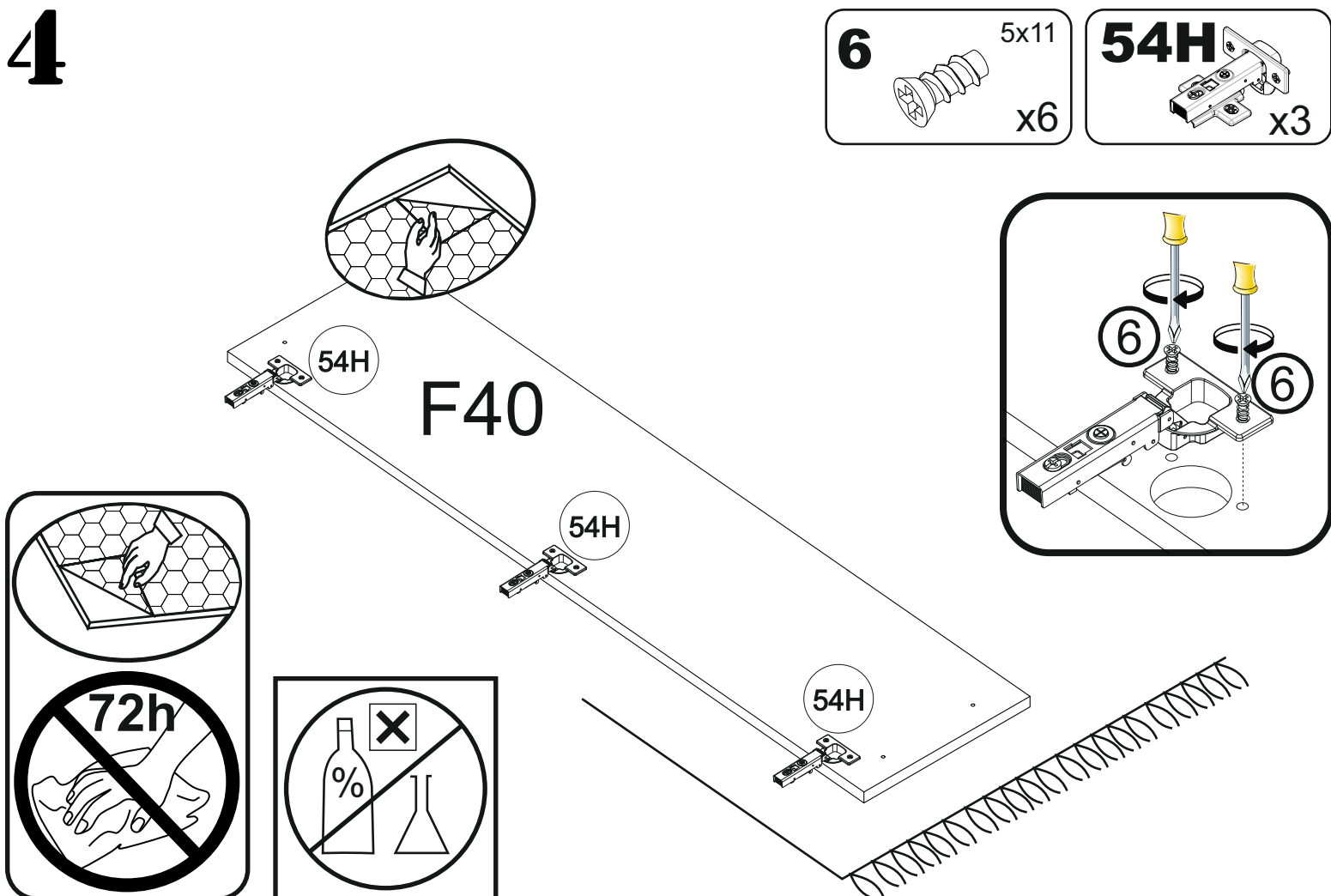

5

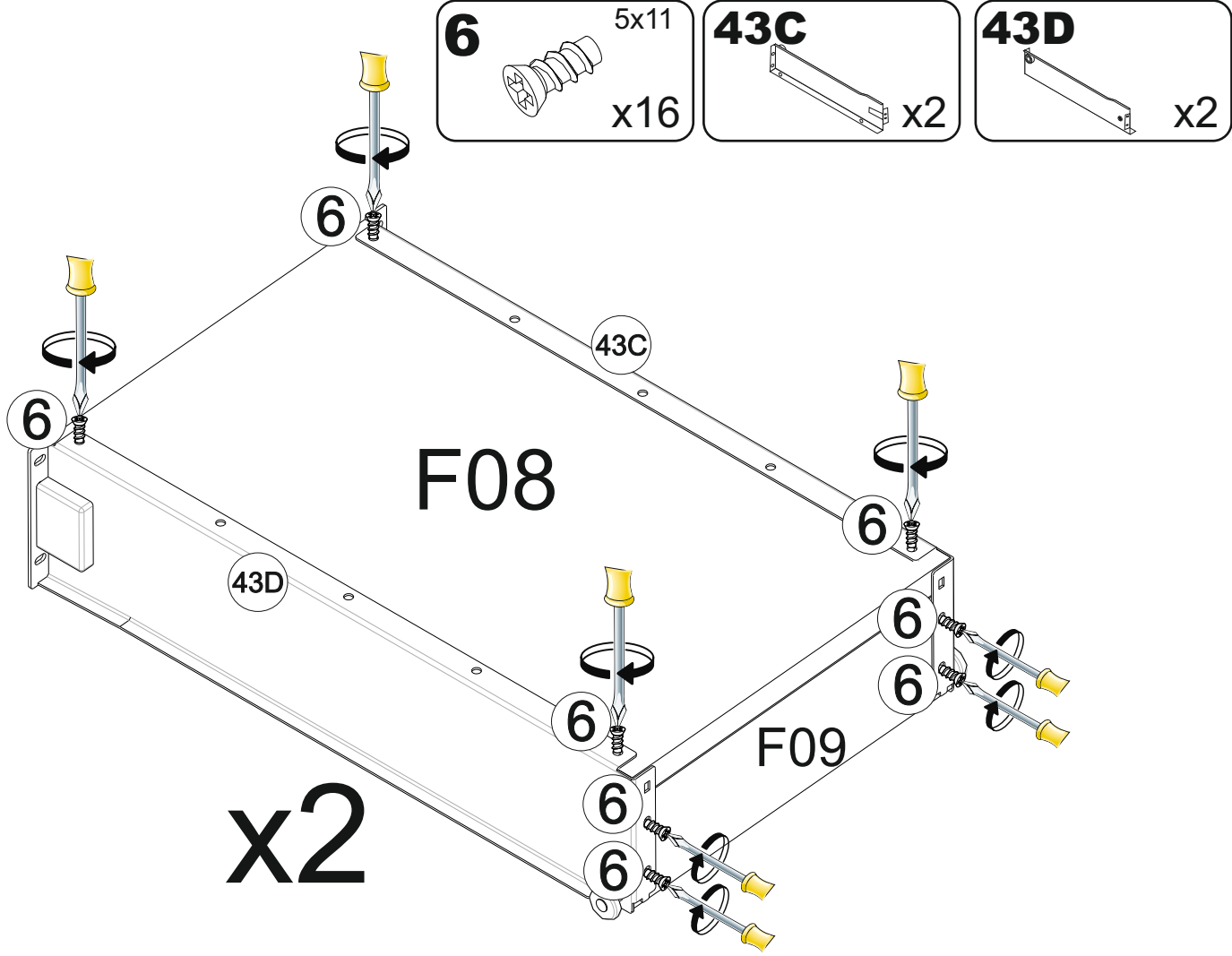

6

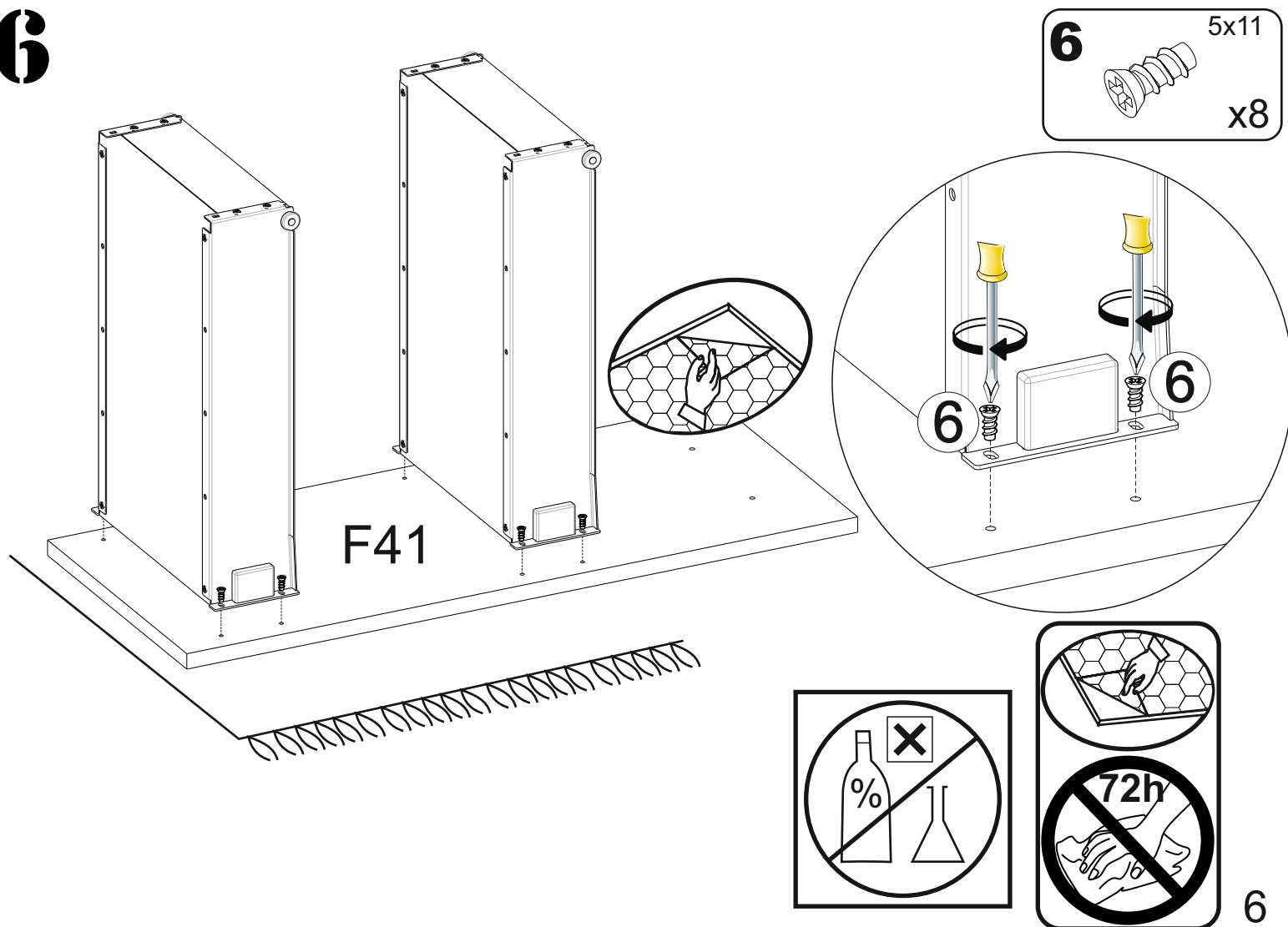

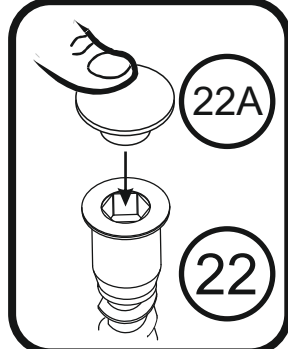
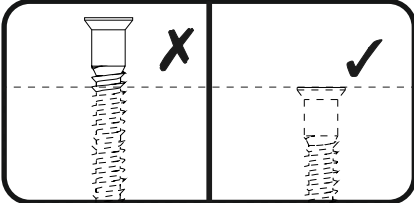
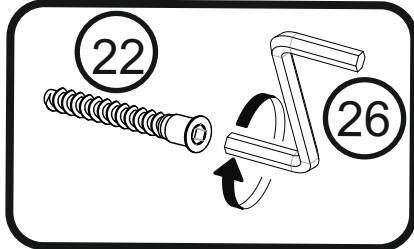
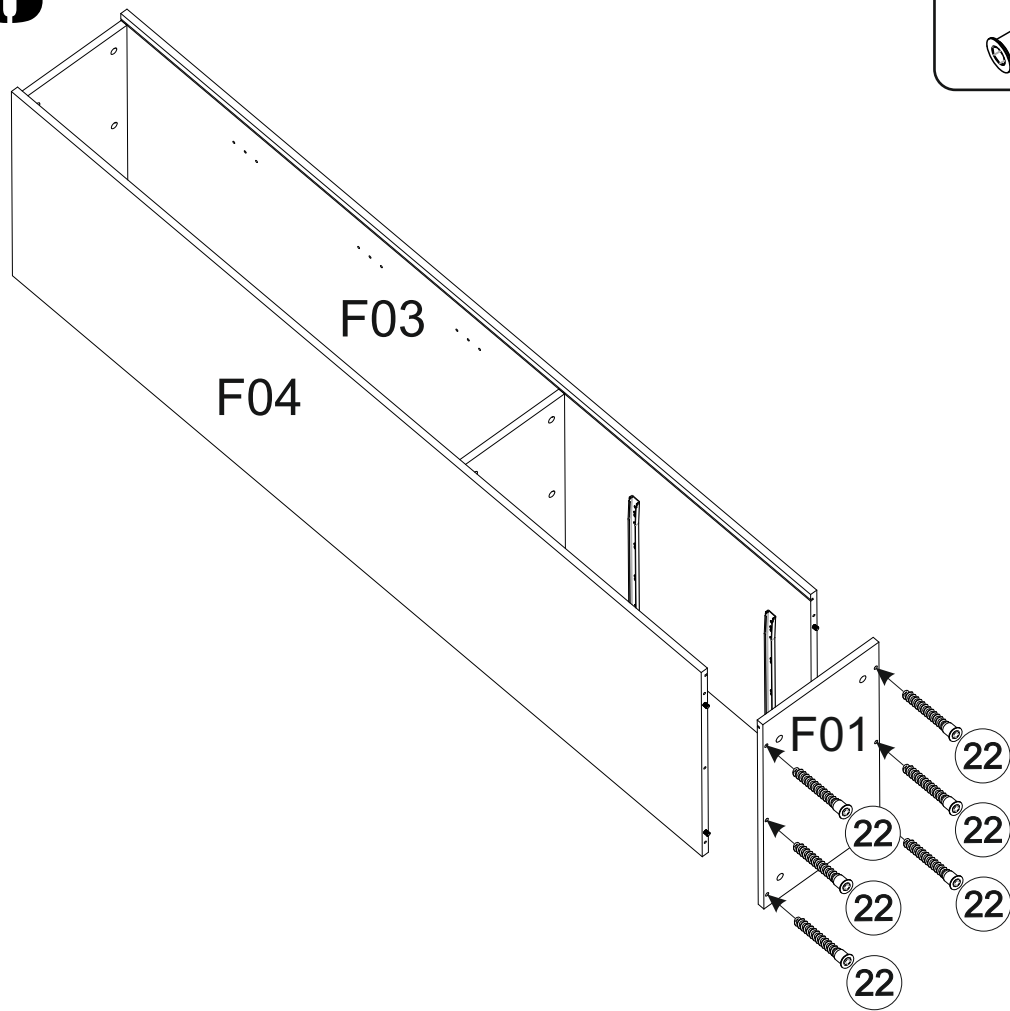
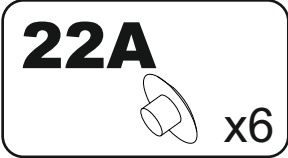
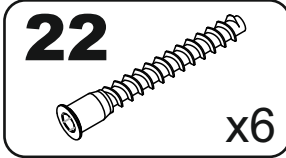
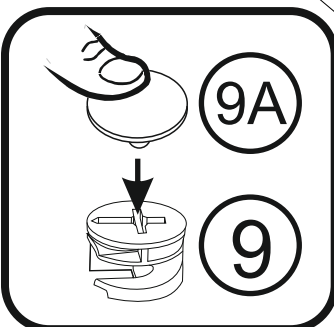
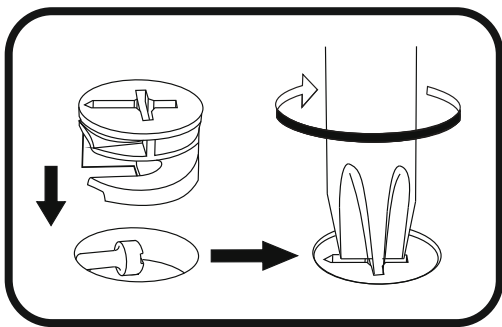
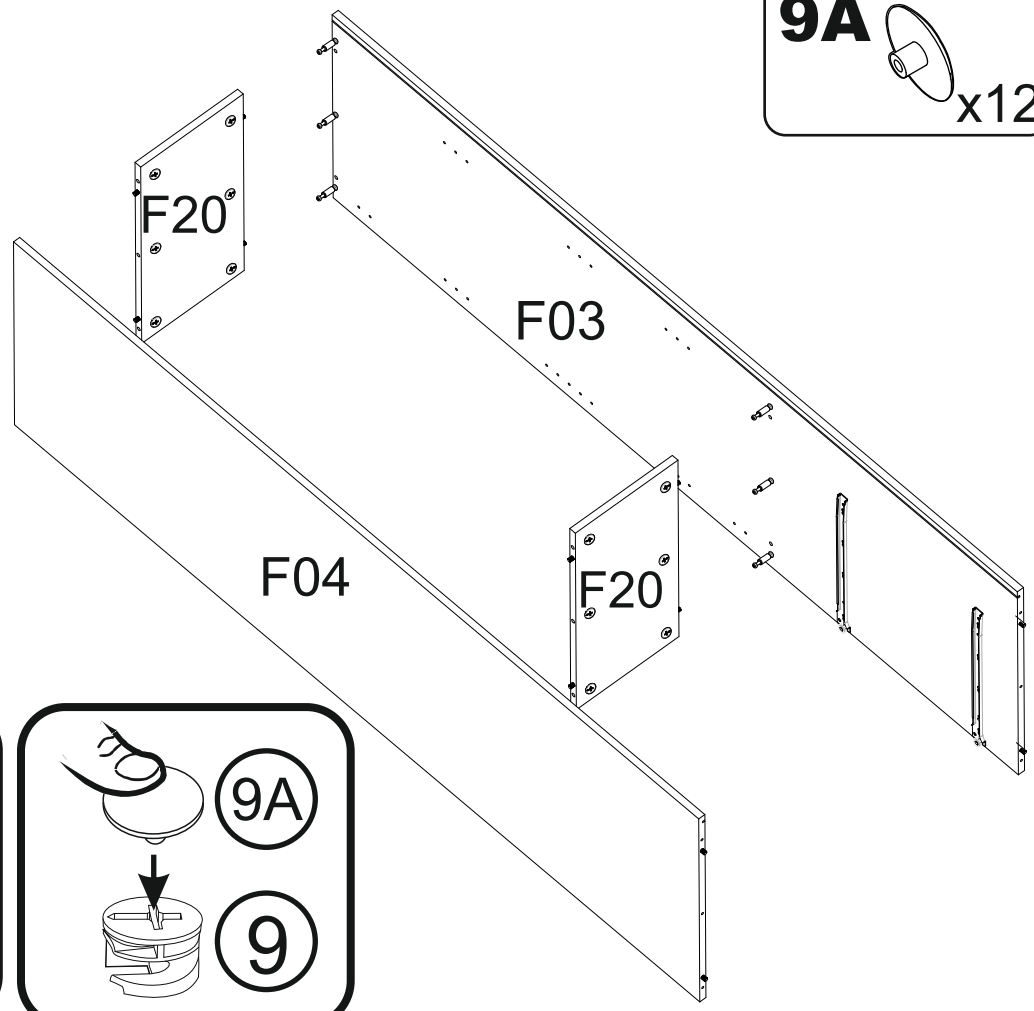
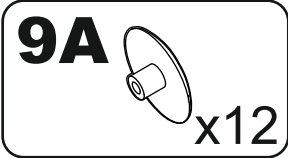

9

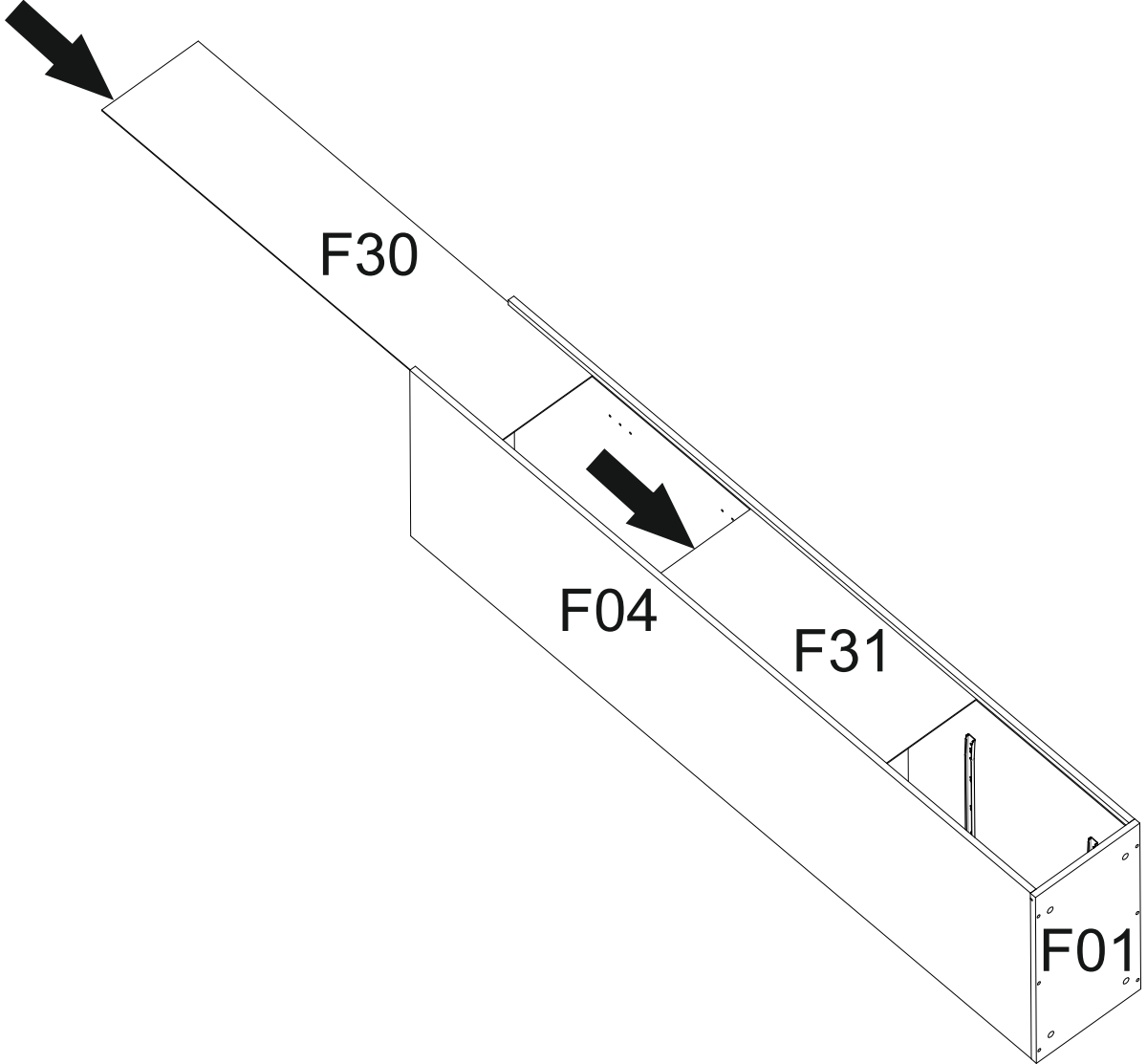

10

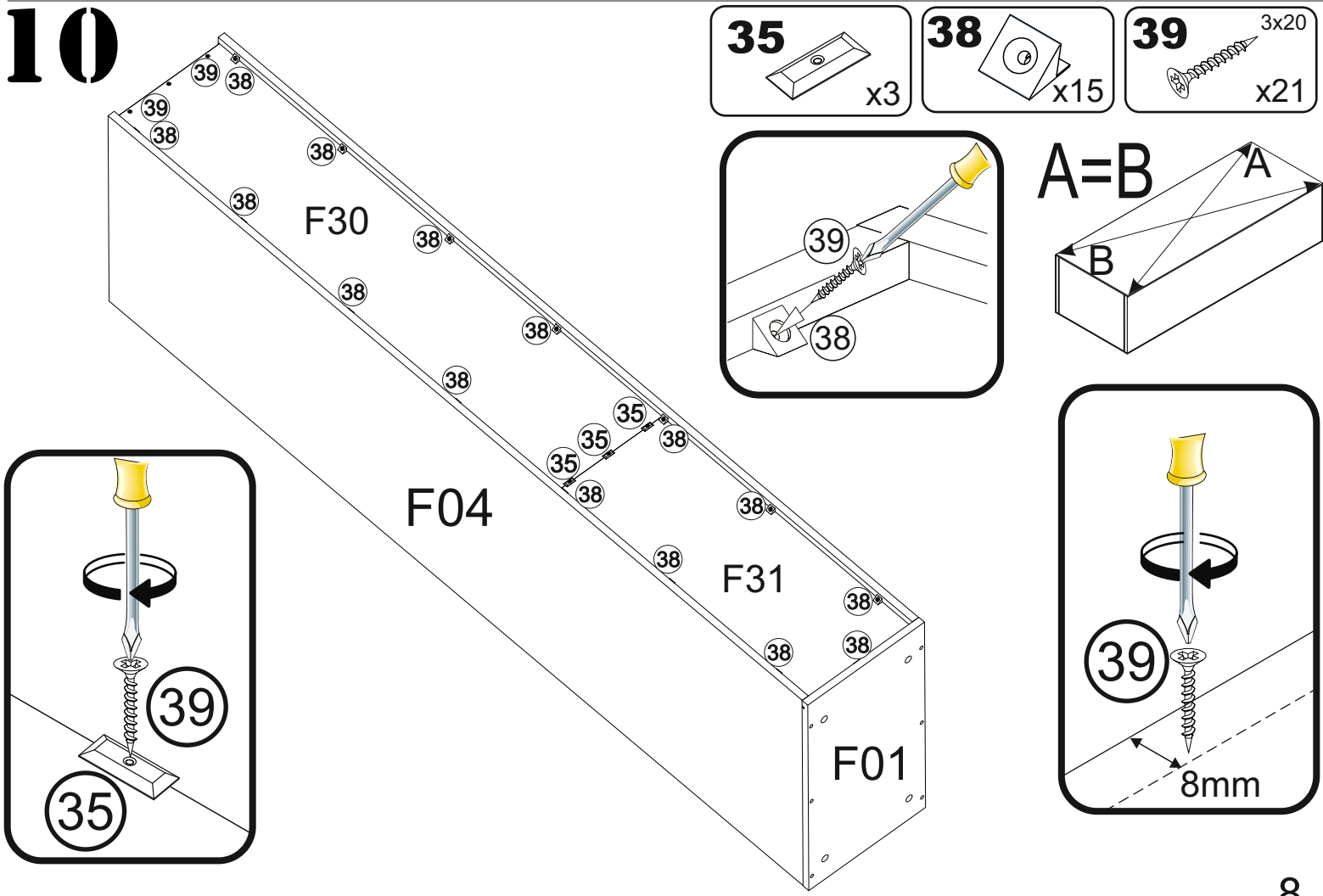

11

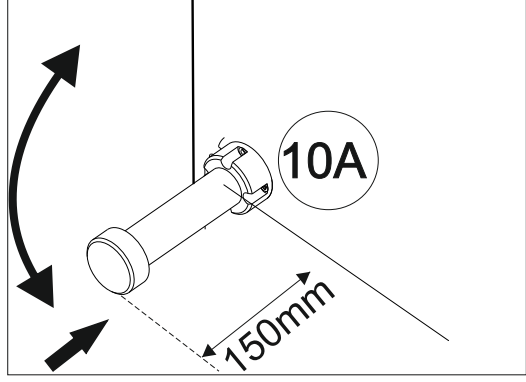
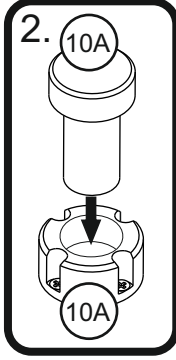
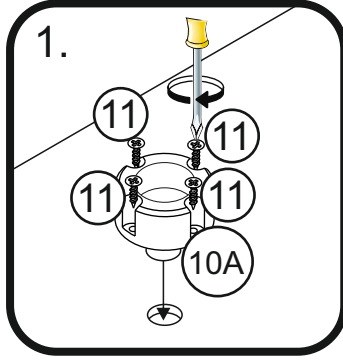
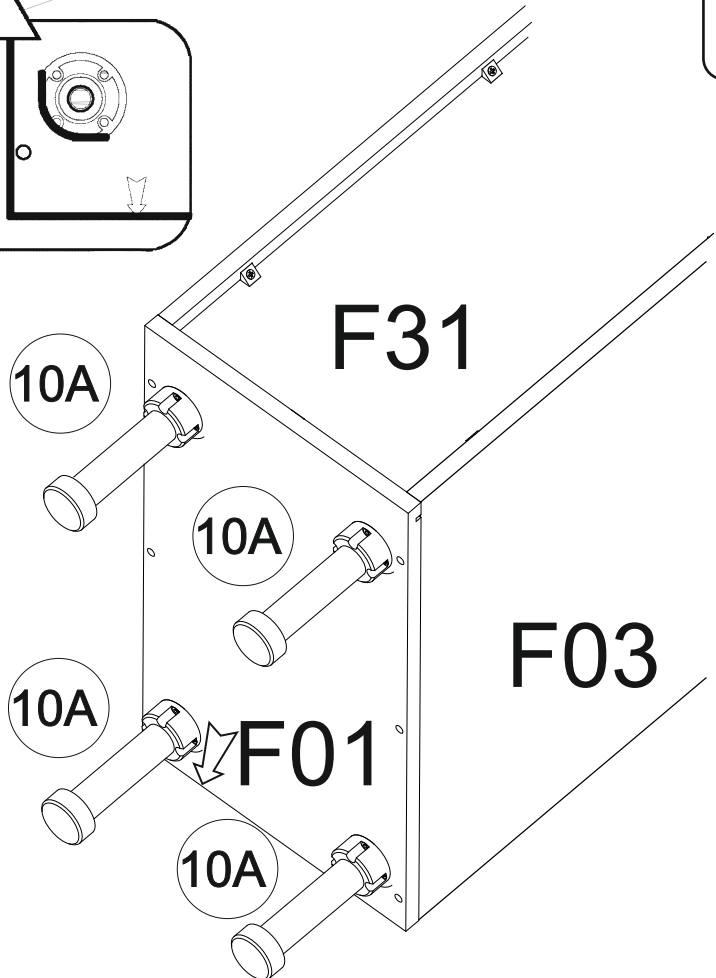
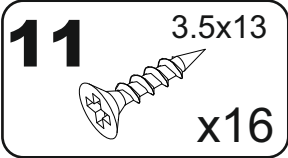
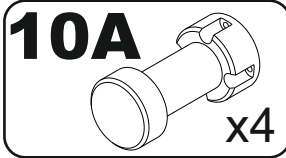
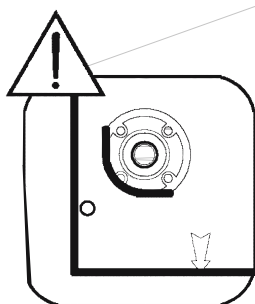

12

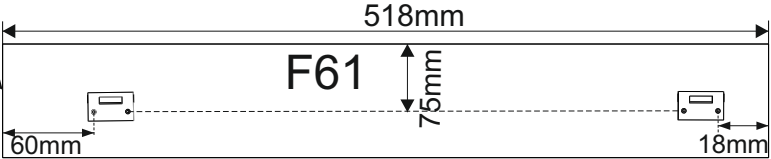
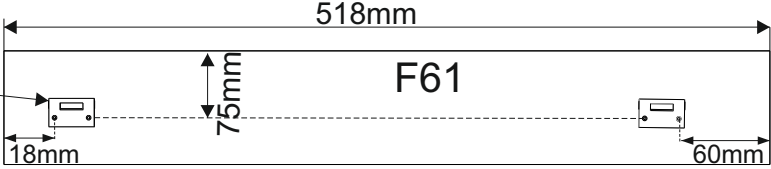
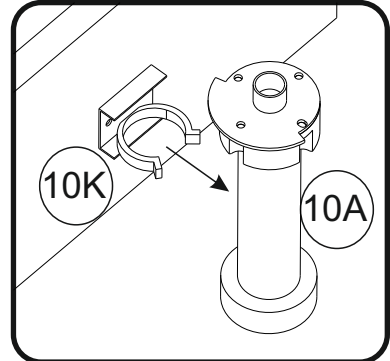
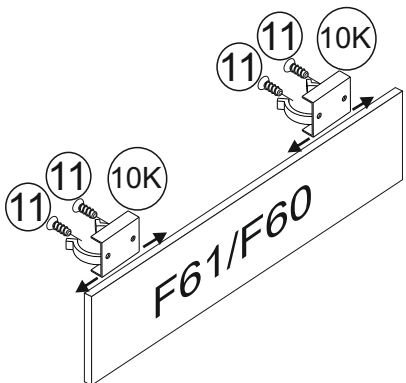
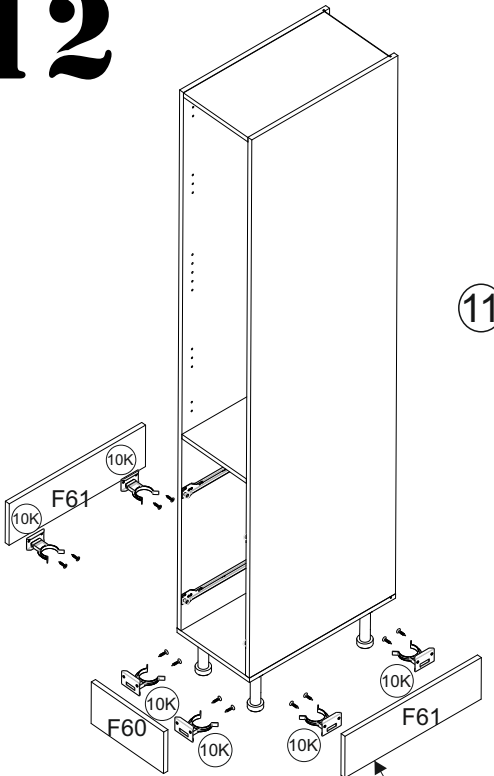
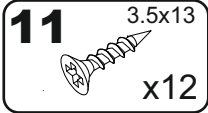
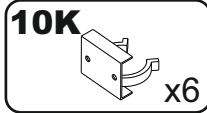

F61/F60

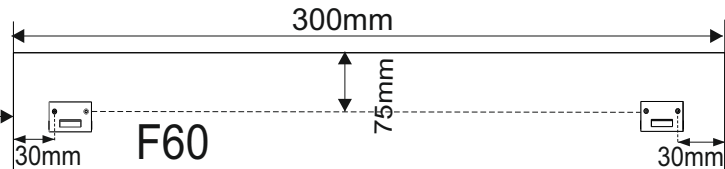
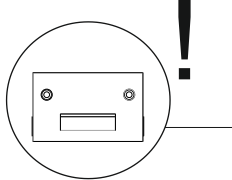

13

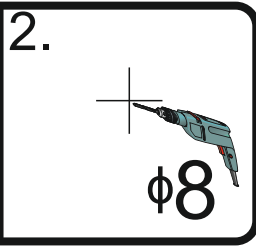
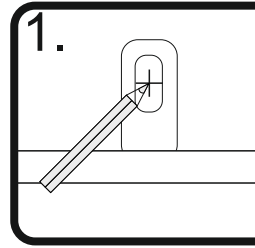
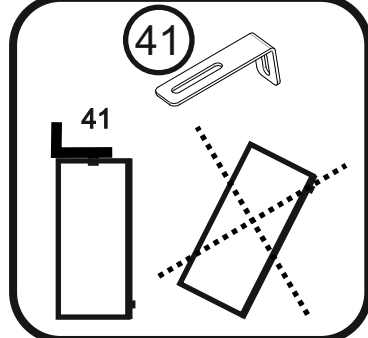
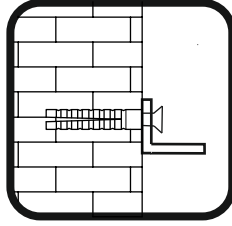
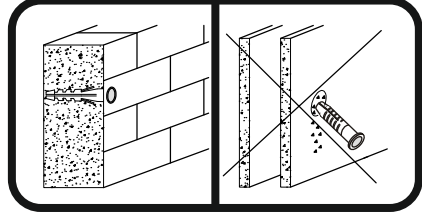
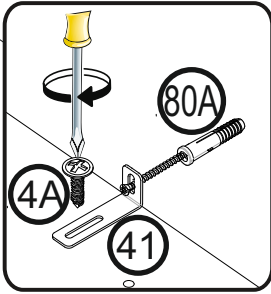
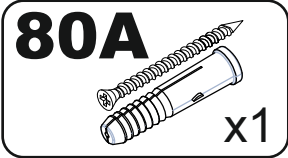
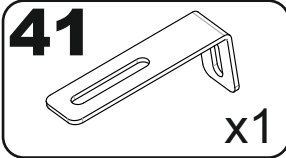
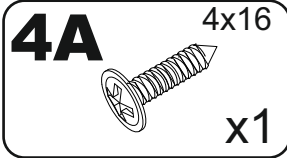
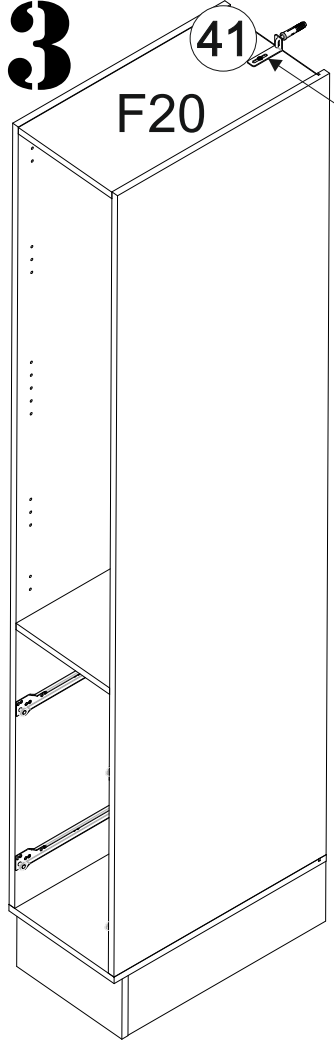

14

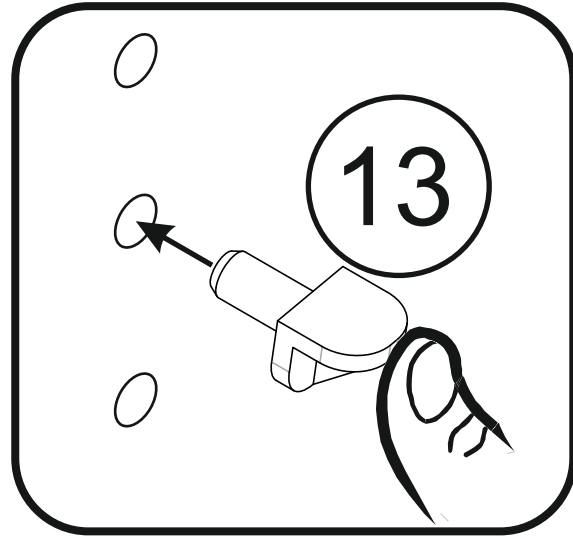
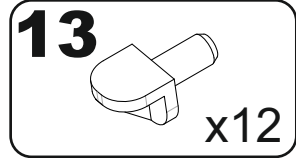
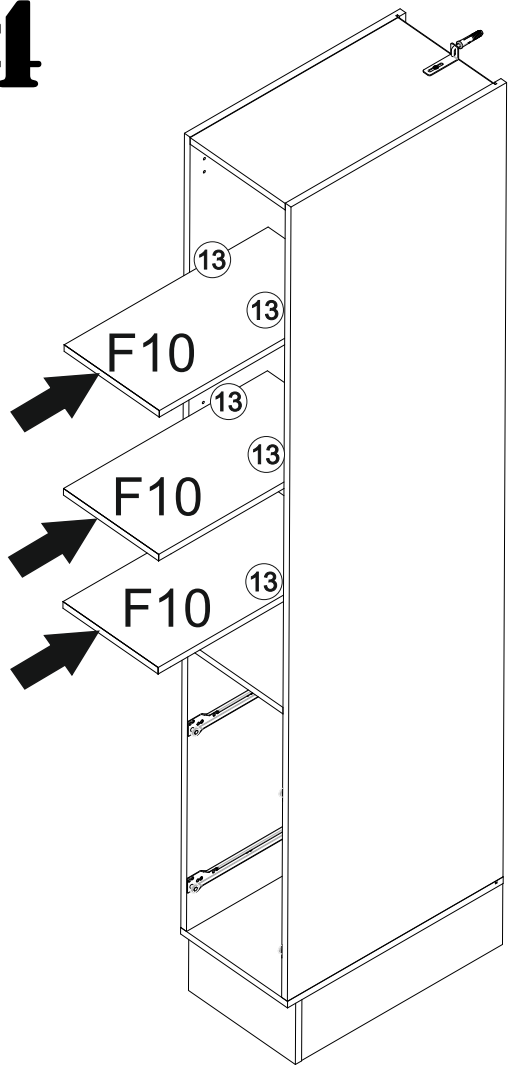

15

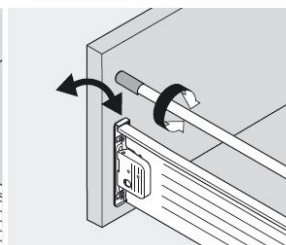
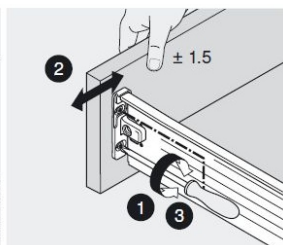
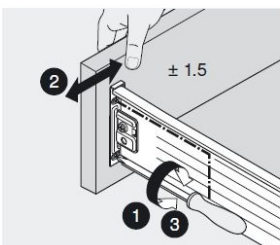
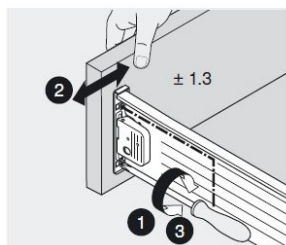
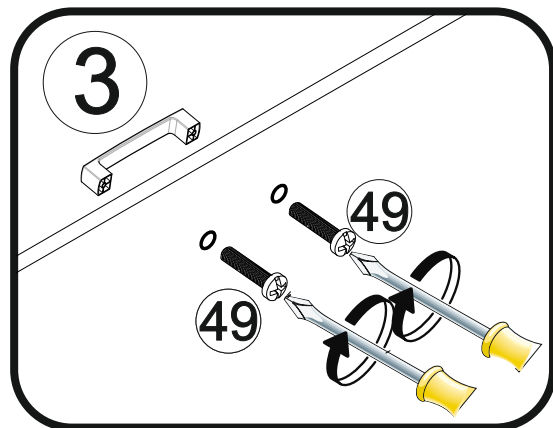
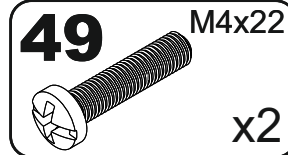
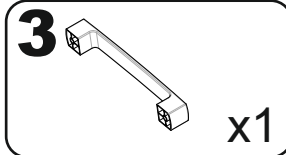
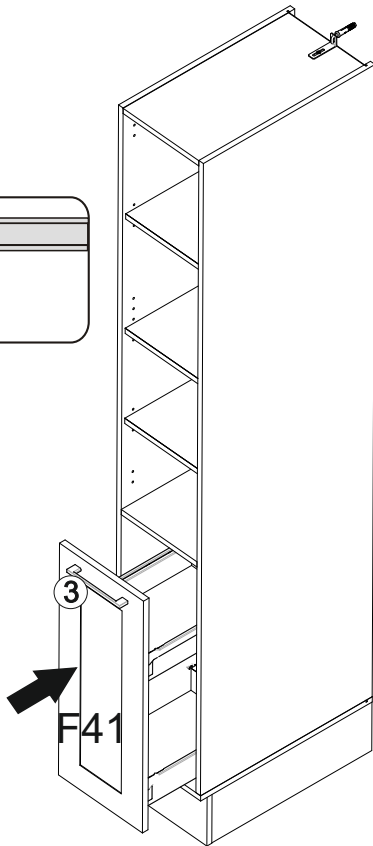
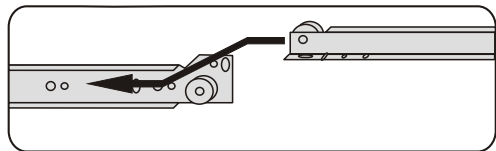

16

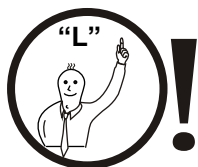
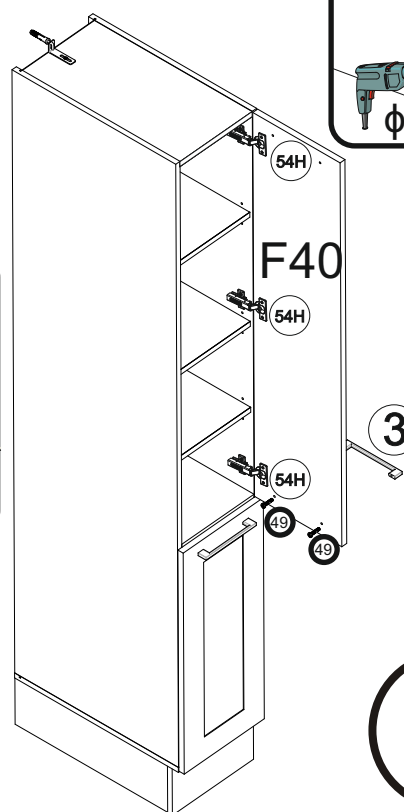
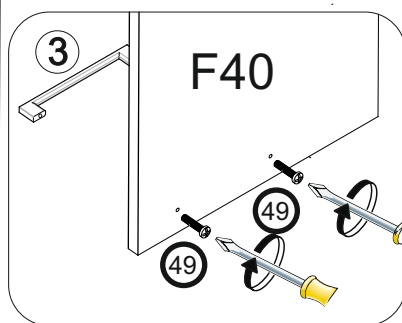
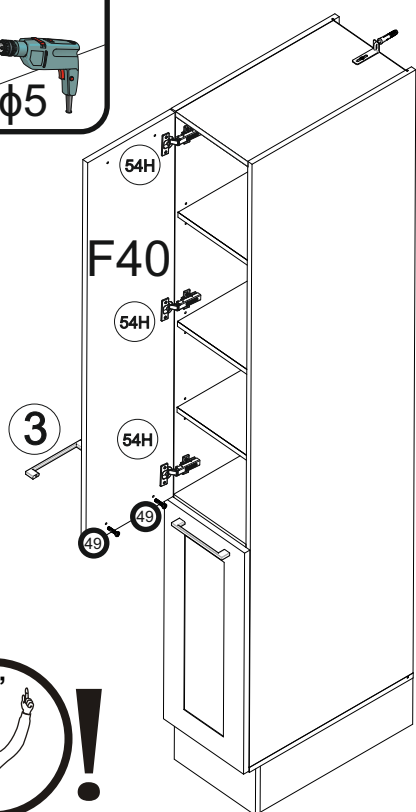
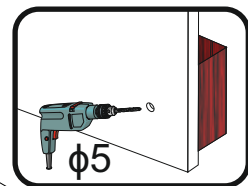
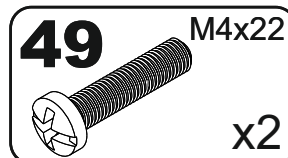
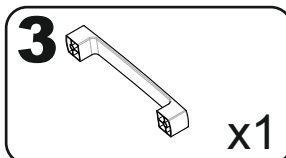
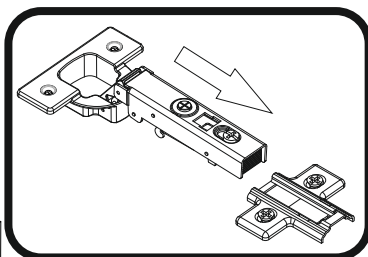
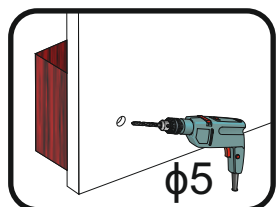

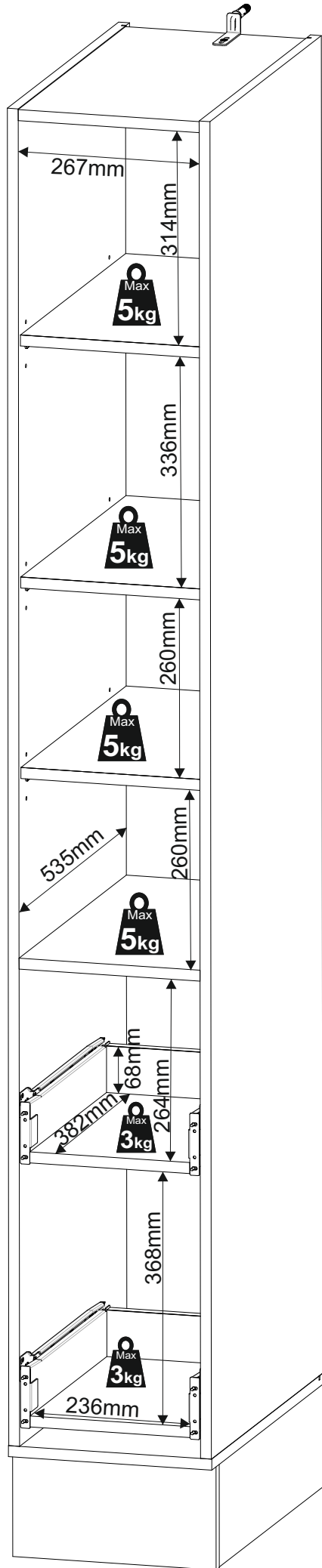
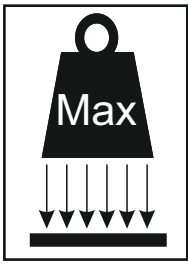

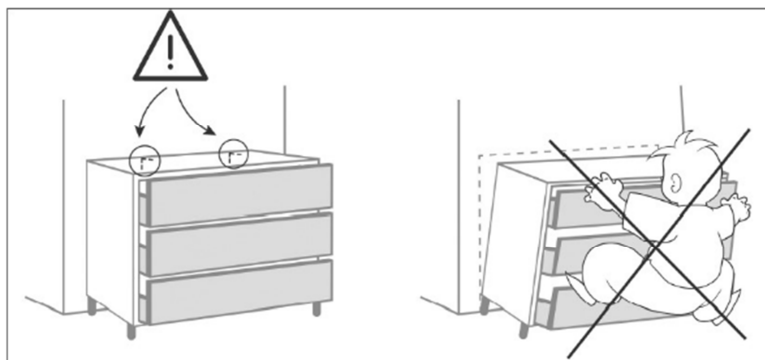
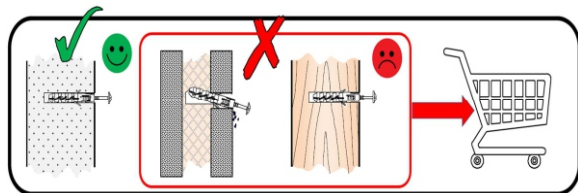

DE	<p>Warnhinweis: Wenn der Ware Dübel und Schrauben beiliegen, sind sie ausschließlich zur Anwendung an Wänden aus massiven und einheitlichen Materialien bestimmt, um ein Umkippen zu verhindern. Vergewissern Sie sich vor dem Bohren, dass sich keine Gas-, Wasser-, oder Stromleitungen an der Bohrstelle befinden. Zur Befestigung an anderen Wänden müssen Spezialdübel verwendet werden. Erkundigen Sie sich im Handel nach den für die jeweilige Wandbeschaffenheit geeigneten Schrauben und oder Dübel. Für eine unsachgemäße Montage und dadurch entstandene Schäden übernimmt der Hersteller keine Haftung. Bitte alle Schrauben in regelmäßigen Abständen überprüfen und nachziehen.</p>
FR	<p>Avertissement : Si des chevilles et des vis sont fournies avec l'article, elles sont exclusivement destinées à être utilisées sur des murs en matériaux massifs et homogènes pour éviter tout basculement. Avant de percer, assurez-vous qu'aucune conduite de gaz, d'eau ou d'électricité ne se trouve à l'endroit où vous percez. Pour la fixation sur d'autres murs, il faut utiliser des chevilles spéciales. Renseignez-vous en magasin sur les vis et les chevilles adaptées à chaque type de mur. Le fabricant décline toute responsabilité en cas de montage incorrect et de dommages qui en résulteraient. Veuillez vérifier et resserrer toutes les vis à intervalles réguliers.</p> <p>ATTENTION ! Les meubles contenant des panneaux à base de bois (panneaux de particules, panneaux de fibres, contreplaqué...) peuvent émettre des substances polluantes dans l'air intérieur. Il est ainsi recommandé, après l'installation du meuble dans son logement, d'aérer fréquemment la pièce concernée pendant au moins quatre semaines afin de réduire son exposition aux polluants émis par le meuble</p> <p>LED : Ce luminaire est un produit de décoration. Ce luminaire ne convient pas pour l'éclairage principal d'une pièce de la maison.</p>
UK	<p>Warning: If dowels and screws are included with the product, they are only intended for use on walls made of solid and uniform materials to prevent them from tipping over. Before drilling, make sure that there are no gas, water or electricity pipes at the drilling site. Special anchors must be used for fastening to other walls. Ask in the trade for the screws and or dowels suitable for the respective wall condition. The manufacturer accepts no liability for improper installation and any resulting damage. Please check and retighten all screws at regular intervals.</p>
IT	<p>Avvertenza: Se con il prodotto sono forniti tasselli e viti, questi sono destinati esclusivamente all'utilizzo su pareti realizzate con materiali solidi ed uniformi, per evitare il ribaltamento. Prima di eseguire i fori assicurarsi che non ci siano condutture di gas, acqua o elettriche vicino al punto di perforazione. Per il fissaggio ad altre pareti è necessario utilizzare tasselli speciali. Chiedere al proprio rivenditore le viti e/o tasselli adatti al tipo di parete in questione. Il produttore non si assume alcuna responsabilità in caso di montaggio improprio e dei danni che ne derivano. Controllare e serrare tutte le viti a distanza regolare.</p>
PL	<p>Ostrzeżenie: Jeżeli do towaru dołączone są kołki i śruby, są one przeznaczone wyłącznie do stosowania na ścianach wykonanych z solidnych i jednorodnych materiałów, aby zapobiec przewróceniu. Przed rozpoczęciem wiercenia należy upewnić się, że w miejscu wiercenia nie są ułożone rury gazowe, wodociągowe lub przewody elektryczne. Do mocowania do innych ścian należy stosować kołki specjalne. O śruby lub kołki odpowiednie dla konstrukcji danej ściany należy pytać w sklepach specjalistycznych. Producent nie ponosi odpowiedzialności za nieprawidłowy montaż i wyniki z tego tytułu szkody. Wszystkie śruby należy regularnie sprawdzać i dokręcać.</p>
ESP	<p>Advertencia: En el caso de incluirse tacos y tornillos con la mercancía, estos están previstos únicamente para su uso en paredes macizas y homogéneas a fin de evitar un posible vuelco. Antes de taladrar, asegúrese de que por el punto de perforación no pasan tuberías de gas o agua o cables eléctricos. Para la fijación en otro tipo de paredes deben utilizarse tacos especiales. Pregunte en la tienda por los tornillos o tacos adecuados para las características de la pared en cuestión. El fabricante no asume ninguna responsabilidad por un montaje incorrecto ni por los daños resultantes del mismo. Compruebe todos los tornillos en intervalos regulares y apriételes.</p>
CZ	<p>Výstražné upozornění: Pokud jsou k výrobku přiloženy hmoždinky a šrouby, jsou určeny výhradně pro použití do stěn zhotovených z masivních a homogenních materiálů, a to za účelem zajištění proti převrácení. Před vrtáním se ujistěte, že se v místě vrtání nenachází vedení plynu, vody nebo elektřiny. Pro připevnění k jiným stěnám je nutné použít speciální hmoždinky. Informujte se v obchodě o hmoždinkách a/nebo šroubech vhodných pro příslušnou strukturu stěny. Výrobce nenese odpovědnost za nesprávnou montáž a za škody jí způsobené. Všechny šrouby pravidelně kontrolujte a dotahujte.</p>
SK	<p>Informácia o nebezpečenstve: Ak sú k tovaru priložené príchytky a skrutky, sú určené výlučne na použitie na stenách z masívnych a jednotných materiálov, aby sa zabránilo prevráteniu. Pred vrtaním sa uistite, že sa na vrtanom mieste nenachádzajú žiadne plynové, vodovodné alebo elektrické vedenia. Na upevnenie na iných stenách musia byť použité špeciálne príchytky. Spýtajte sa v predajni na skrutky a/alebo príchytky vhodné pre príslušný typ steny. Výrobca nepreberá rúčenie za nesprávnu montáž a tým vzniknuté škody. Všetky skrutky v pravidelných intervaloch kontrolujte a dotiahnite.</p>
HU	<p>Figyelmeztetés: Amennyiben a termék csomagolásá tipliket és csavarokat is tartalmaz, azok kizárólag masszív, egységes anyagból készült falakon használhatók, a felborulás megakadályozásának céljából. A fúrás előtt bizonyosodjon meg arról, hogy a fúrás helyén nem található gáz-, víz- vagy elektromos vezeték. Egyéb falakra történő rögzítéshez speciális tiplik szükségesek. Az egyes faltípusokkal használható megfelelő csavarokkal és/vagy tiplikkel kapcsolatos információkért kérjük, forduljon forgalmazójához. A nem szakszerű szerelésért és az abból keletkező károkért a gyártót semmilyen felelősség nem terheli. Minden csavart ellenőrizzen és rögzítsen rendszeresen.</p>
BG	<p>Предупредително указание : Ако в окомплектовката на доставката на стоката са включени дюбели и винтове, те са предназначени единствено за употреба върху стени от масивни и еднородни материали, за да се предотврати преобръщане. Преди пробиване се уверете, че на мястото на пробиване няма тръби за газ, за вода или електрически проводници. За закрепване към други стени трябва да се използват специални дюбели. Информирайте се в търговската мрежа относно подходящите винтове и/или дюбели за съответната конструкция на стената. Производителят не поема отговорност за неправилен монтаж и възникнали в резултат на това щети. Моля, проверявайте и затягвайте всички винтове на редовни интервали.</p>

TR	Uyarı: Ürün paketinde dübel ve vida varsa, bunlar devrilmeyi önlemek amacıyla, sadece masif ve yekpare malzemelerden imal edilmiş duvarlardaki kullanım için öngörülmüştür. Matkapla delik açmadan önce delme noktasında gaz, su veya elektrik hatlarının olmadığından emin olun. Ürünü başka duvarlara sabitlemek için özel dübeller kullanılmamalıdır. Piyasadaki satıcılardan ilgili duvarın özelliğine uygun vidalar ve dübeller hakkında bilgi alın. Usulüne aykırı bir montaj ve bu nedenle oluşmuş hasarlar için üretici sorumluluk almamaktadır. Lütfen tüm vidaları düzenli aralıklarla kontrol edip tekrar sıkın.
PT	Advertência: Caso o produto venha com buchas e parafusos incluídos, os mesmos são exclusivamente destinados à fixação em paredes de materiais sólidos e uniformes, para evitar que o produto tombe. Antes de iniciar a perfuração, certifique-se de que não existem canalizações de gás, água ou fios elétricos a passar no local dos furos. Para a fixação noutro tipo de paredes, têm de ser utilizadas buchas especiais. Informe-se junto de um comerciante especializado sobre os parafusos e buchas a utilizar na parede específica. O fabricante não assume qualquer responsabilidade no caso de uma montagem inadequada e qualquer dano daí resultante. Verifique e volte a apertar todos os parafusos regularmente.
SI	Opozorilo: če so blagu priloženi zidni vložki in vijaki, so ti namenjeni izključno za uporabo na stenah iz masivnih in enotnih materialov, da se prepreči prevrnitev. Pred vrtnanjem se prepričajte, da na mestu vrtnanja ni plinskih, vodnih ali električnih napeljav. Za pritrditev na druge stene je treba uporabljati posebne zidne vložke. Pozanimajte se v trgovini o vijakih in/ali zidnih vložkih, primernih za posamezno sestavo stene. Proizvajalec ne prevzema jamstva za nepravilno montažo in zaradi tega nastalo škodo. Vse vijake redno preverjajte in naknadno privijajte.
NL	Waarschuwing: Indien er bij het product pluggen en schroeven zijn meegeleverd, zijn deze uitsluitend bestemd om in muren van massieve en homogene materialen te gebruiken om te voorkomen dat het product kantelt. Controleer voordat u begint of er geen gas-, water- of elektriciteitsleidingen lopen waar u gaat boren. Voor de bevestiging aan andere soorten muren moeten speciale pluggen worden gebruikt. Informeer in de winkel welke schroeven en/of pluggen geschikt zijn voor de desbetreffende muur. De fabrikant is niet aansprakelijk voor een onjuiste montage en de daardoor ontstane schade. Controleer regelmatig of alle schroeven nog goed vastzitten en draai ze zo nodig vast.
SRB	Upozoravajuća napomena: Ako su uz robu priloženi tiplovi i zavrtnji, isti su namenjeni isključivo za primenu na zidovima od kompaktnih i homogenih materijala, kako bi se sprečilo prevrtanje. Pre bušenja se uverite da se na mestu bušenja ne nalaze vodovi za gas, vodu ili struju. Za fiksiranje na drugačijim zidovima moraju da se upotrebe specijalni tiplovi. Raspitajte se u trgovini o zavrtnjima i/ili tiplovima koji su adekvatni za dotičnu teksturu zida. Proizvođač ne preuzima nikakvu odgovornost za nestručnu montažu i štete koje su nastale na taj način. Sve zavrtnje kontrolišite i dotežite u redovnim intervalima.
RO	Indicație de avertizare: Dacă produsul este livrat împreună cu șuruburi și dibluri, acestea sunt destinate exclusiv utilizării pe pereții construiți din materiale masive și uniforme, pentru a preveni răsturnarea produsului. Înainte de a realiza găurile, asigurați-vă că nu există conducte de gaz, apă sau electricitate în locul pe care doriți să-l găuriți. Pentru prinderea pe alte tipuri de pereți, trebuie să utilizați dibluri speciale. Interesați-vă la magazinul specializat, pentru a găsi șuruburile și/sau diblurile potrivite pentru peretele dvs. Producătorul nu este responsabil, în cazul unui montaj necorespunzător pentru daunele rezultate. Vă rugăm să verificați toate șuruburile la intervale regulate și să le strângeți.
HR	Upozorenje: Ako su uz proizvod priložene tiple i vijci, oni su namijenjeni isključivo za korištenje na zidovima od čvrstih i jednoličnih materijala kako bi se spriječilo prevrtanje. Prije bušenja provjerite da na mjestu bušenja nema električnih vodova, plinskih ili vodovodnih cijevi. Za pri čvršćivanje na ostale zidove potrebno je koristiti posebne tiple. Prilikom kupnje raspitajte se kod svog prodavača o vijcima i tiplama koji su prikladni za odgovarajuću zidnu strukturu. Proizvođač ne odgovara za štete nastale uslijed nepravilne montaže. Sve vijke potrebno je redovito provjeravati i zategnuti.
SE	Varning: Om plugg och skruvar följer med produkten är de endast avsedda för väggar av massivt och enhetligt material för att förhindra att produkten vippar. Försäkra dig om att inga gas-, vatten- eller elledningar befinner sig på platsen som du ska borra innan du börjar. För fastsättning i väggen måste specialplugg användas. Informera dig i en butik om vilka skruvar och plugg som passar till vilken vägg. För en felaktig montering och skador som uppstår på grund av detta tar tillverkaren inget ansvar. Kontrollera och dra åt alla skruvar med jämna mellanrum.
RUS	Предупреждение: Если изделие поставляется вместе с дюбелями и шурупам, они предназначены исключительно для использования на стенах из монолитных и однородных материалов, чтобы предотвратить возможное обрушение. Перед началом сверления убедитесь, что на месте сверления нет газопровода, водопровода или электропроводки. Для крепления к другим стенам необходимо использовать специальные дюбели. Узнайте у продавца, какие шурупы или дюбели подходят для соответствующей структуры стены. Производитель не несет ответственности за неправильный монтаж и вызванный им ущерб. Регулярно проверяйте и подтягивайте все шурупы.
UKR	Попередження: Якщо до виробу додаються дюбелі та гвинти, вони призначені виключно для використання на стінах з цільних й однорідних матеріалів, щоб не допустити перекидання. Перед сверлінням переконайтеся, що на місці сверління немає ліній газо-, водопостачання чи електропроводки. Для кріплення до інших стін необхідно використовувати спеціальні дюбелі. Запитайте продавця, які гвинти та/або дюбелі підходять для стіни з відповідною структурою. Виробник не несе відповідальності за неправильний монтаж та збитки, що виникли внаслідок цього. Перевіряйте та підтягуйте всі гвинти через регулярні проміжки часу.
LT	Įspėjimas: jei prie prekės pridėtos mūrvinės ir varžtai, jie skirti naudoti tik ant sienų, pagamintų iš tvirtų ir vienodų medžiagų, kad būtų galima išvengti apvirtimo. Prieš gręždami įsitinkite, kad gręžiamoje vietoje nėra dujotiekio, vandentiekio ar elektros linijų. Tvirtinant prie kito tipo sienų reikia naudoti specialias mūrvines. Teiraukitės pardavėjo atitinkamai sienos konstrukcijai tinkamų varžtų ir (arba) mūrvinių. Gamintojas neprisiima atsakomybės dėl netinkamo montavimo ir dėl to atsiradusios žalos. Visus varžtus reguliariai tikrinkite ir priveržkite.
LV	Brīdinājums: Ja precei ir pievienoti dībeļi un skrūves, prece ir paredzēta izmantošanai tikai uz sienām, kas izgatavotas no cietiem un viendabīgiem materiāliem, lai novērstu apgāšanos. Pirms urbšanas pārlicinieties, ka urbšanas vietā nav gāzes, ūdens vai elektropārvades līniju. Lai piestiprinātu pie citām sienām, jāizmanto speciāli dībeļi. Jautājiet savam izplatītājam par skrūvēm un/vai dībeļiem, kas ir piemēroti attiecīgajai sienas konstrukcijai. Ražotājs neuzņemas atbildību par nepareizu montāžu un no tās sekojošajiem bojājumiem. Lūdzu, regulāri pārbaudiet un pievelciet visas skrūves.
EE	Hoiatus! Kui tootele on kaasa pandud tüüblid ja kruvid, on need mõeldud kasutamiseks üksnes massiivsest ja ühtsest materjalist seintel, vältimaks ümberkukkumist. Veenduge enne puurimist, et puurimiskohas ei oleks gaasi- või veetorusid ega elektrijuhtmeid. Seintele kinnitamiseks tuleb kasutada spetsiaalseid tüüpleid. Uurige kaubandusvõrgust, millised kruvid ja/või tüüblid konkreetselt seina jaoks sobivad. Tootja ei võta endale mittenõuetekohasest paigaldamisest tingitud kahjude eest mingit vastutust. Kontrollige ja järelpingutage kõiki kruvisid regulaarselt.



LE TRI
+ FACILE



FR

Donnez ou recyclez
vos meubles.



Association

ou



Magasin

ou



Déchèterie

<https://quefairedemesdechets.fr>

XXXXXXXXXXXX serie: xxx

 Hergestellt für:

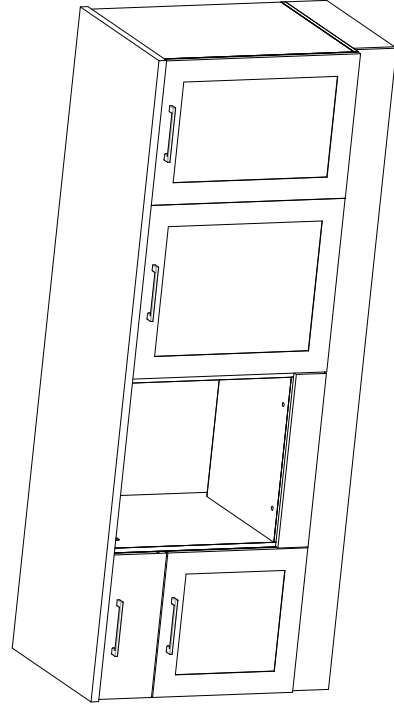
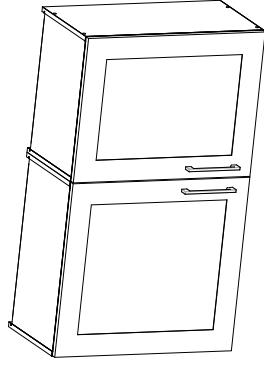
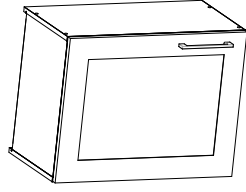
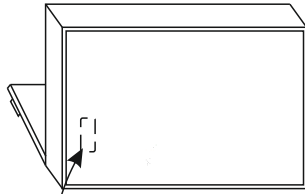







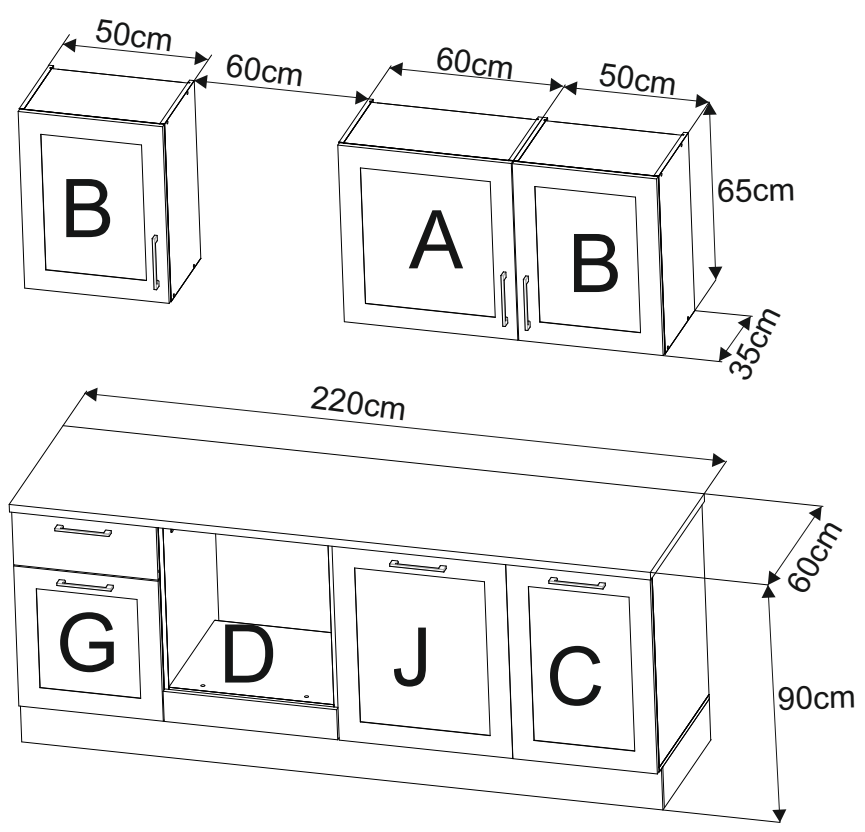
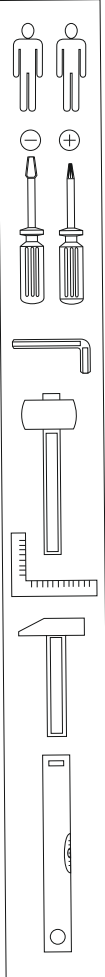

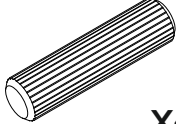
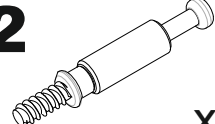
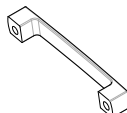
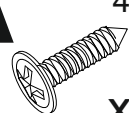
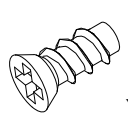
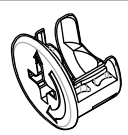

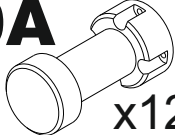
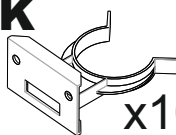
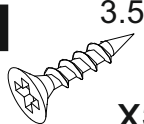
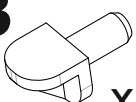
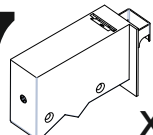
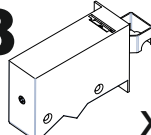
240 min

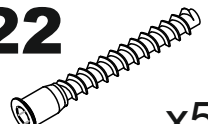

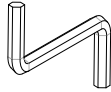
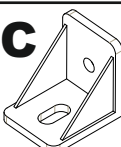
- Correct lifting: two people lifting together.
 - Incorrect lifting: one person lifting alone.
 - Eye protection: wear safety glasses.
 - Hand safety: use 100% cotton gloves.
 - Tool requirements: hammer, pencil, screwdriver, and drill with $\Phi 8$ bit.
 - Assembly order: 1. Lay out parts. 2. Attach base. 3. Attach middle section. 4. Attach top section.

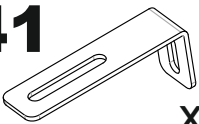

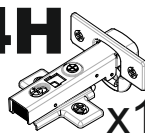
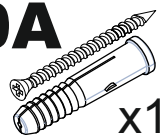
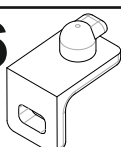
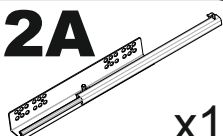
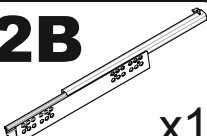
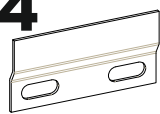
- | | | | | |
|---|---|--|---|---|
| 1

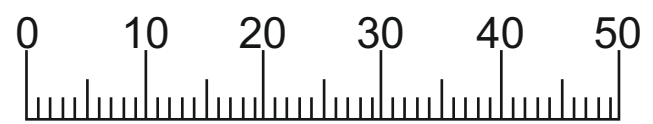
x48 | 2

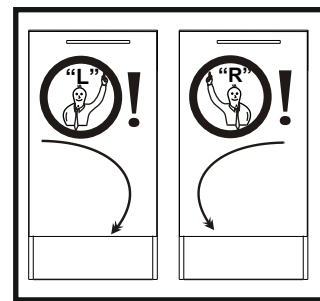
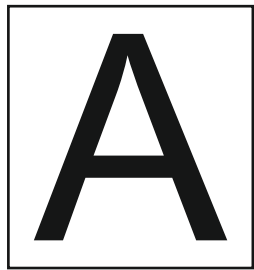
x6 | 3

x7 | 4A

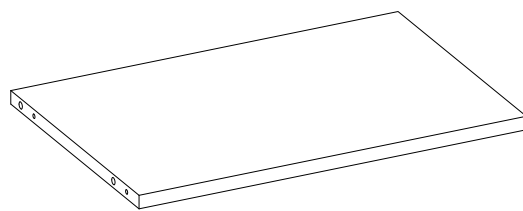
4x16
x26 | 6

5x11
x28 |
| 9

ø15
x4 | 9A

x4 | 10A

x12 | 10K

x10 | 11

3.5x13
x54 |
| 13

x16 | 17

x3 | 18

x3 | 21

4x30
x12 | 22

x52 |
| 22A

x52 | 24

ø12
x2 | 26

x1 | 31C

x8 | 38

x19 |
| 39

3x20
x55 | 41

x4 | 49

M4x22
x14 | 54H

x12 | 80A

x12 |
| 86

x2 | 92A

x1 | 92B

x1 | 94

x6 | |





A20



A30

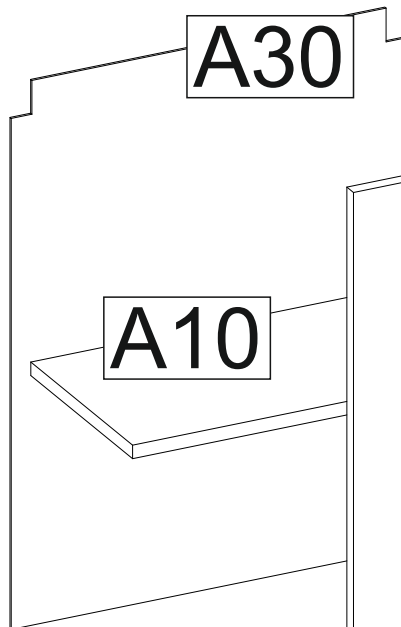

A03

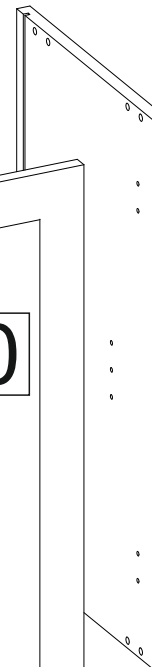

A03

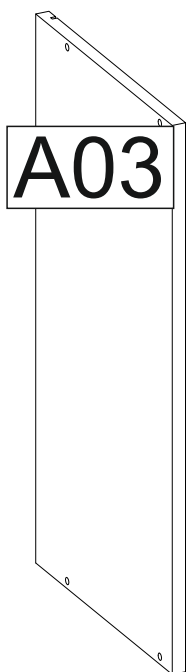

A10

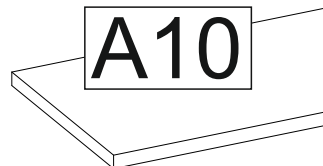

A40

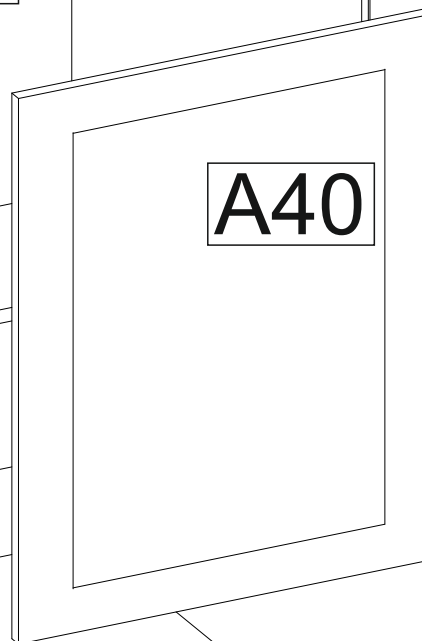

A20

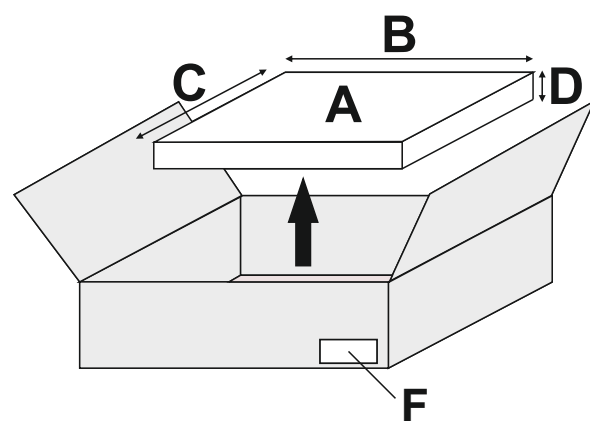

A	B_(mm)	C_(mm)	D_(mm)	E	F
A03	650	330	16	2	1 6
A10	567	246	16	1	1 6
A20	567	310	16	2	1 6
A30	644	577	3	1	1 6
A40	596	646	18	1	1 6

1

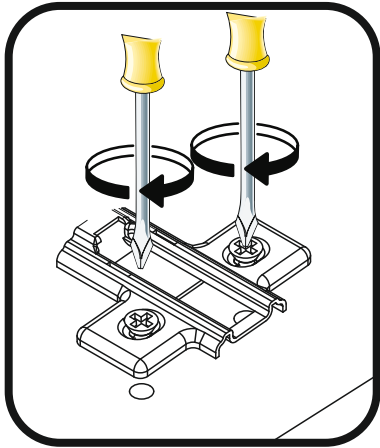
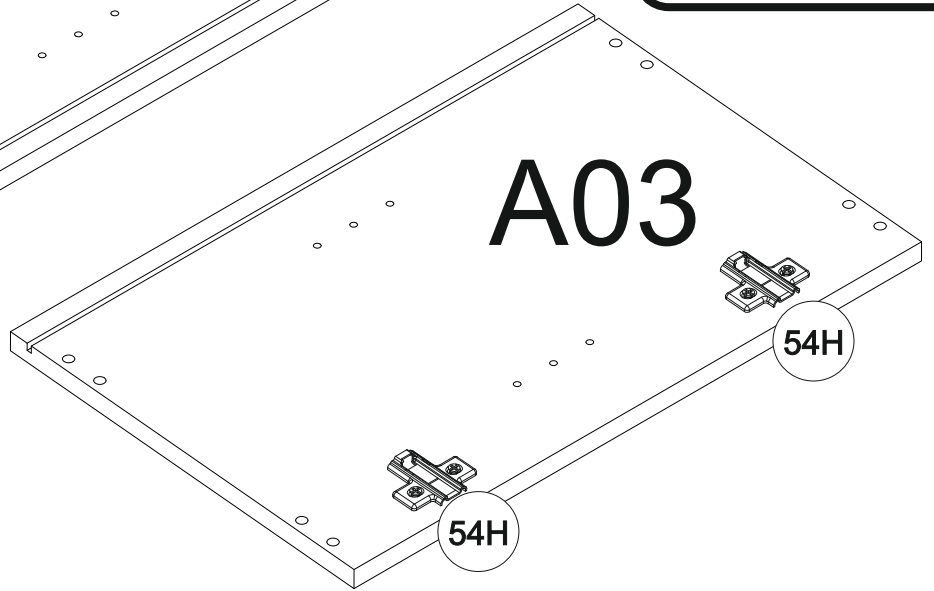
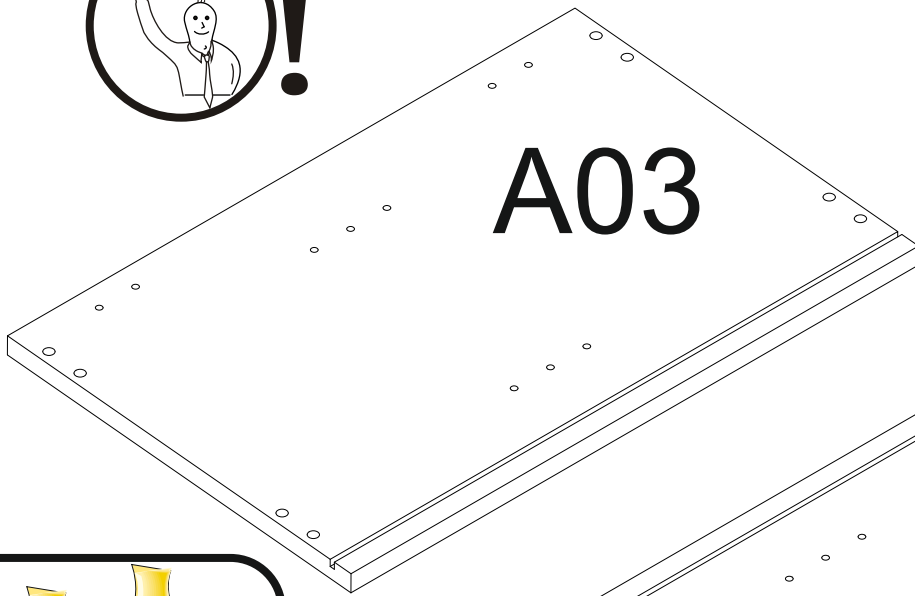
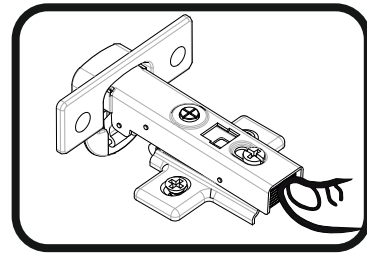
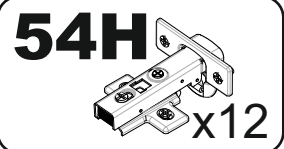

2

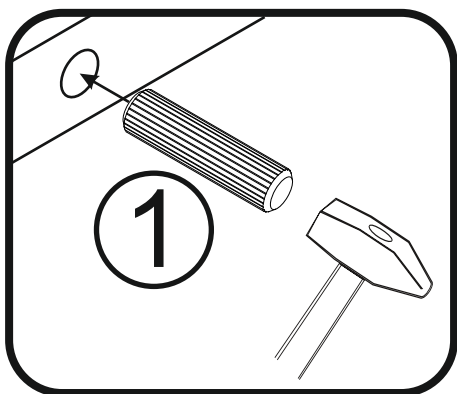
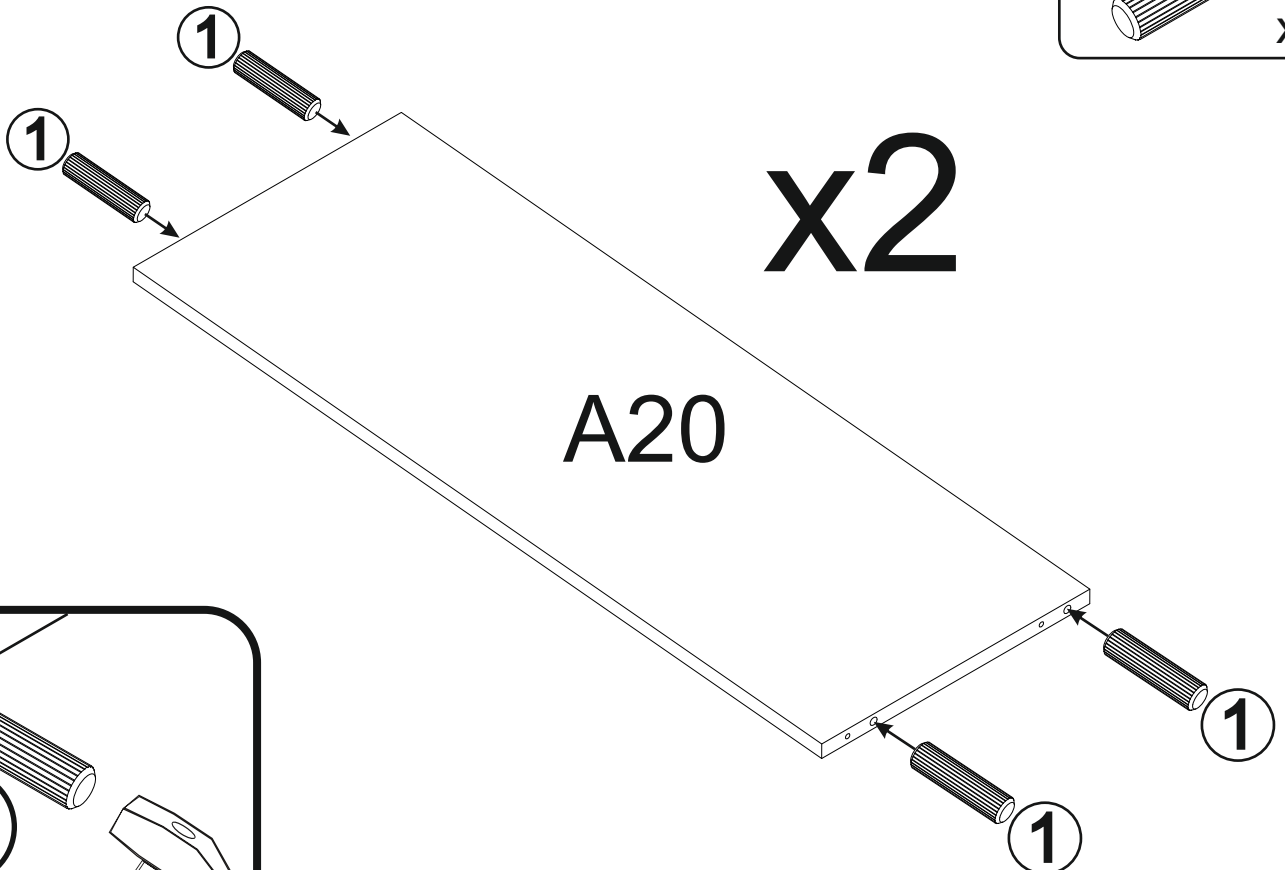
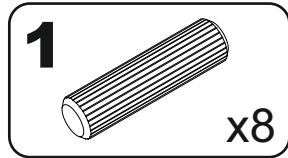

3

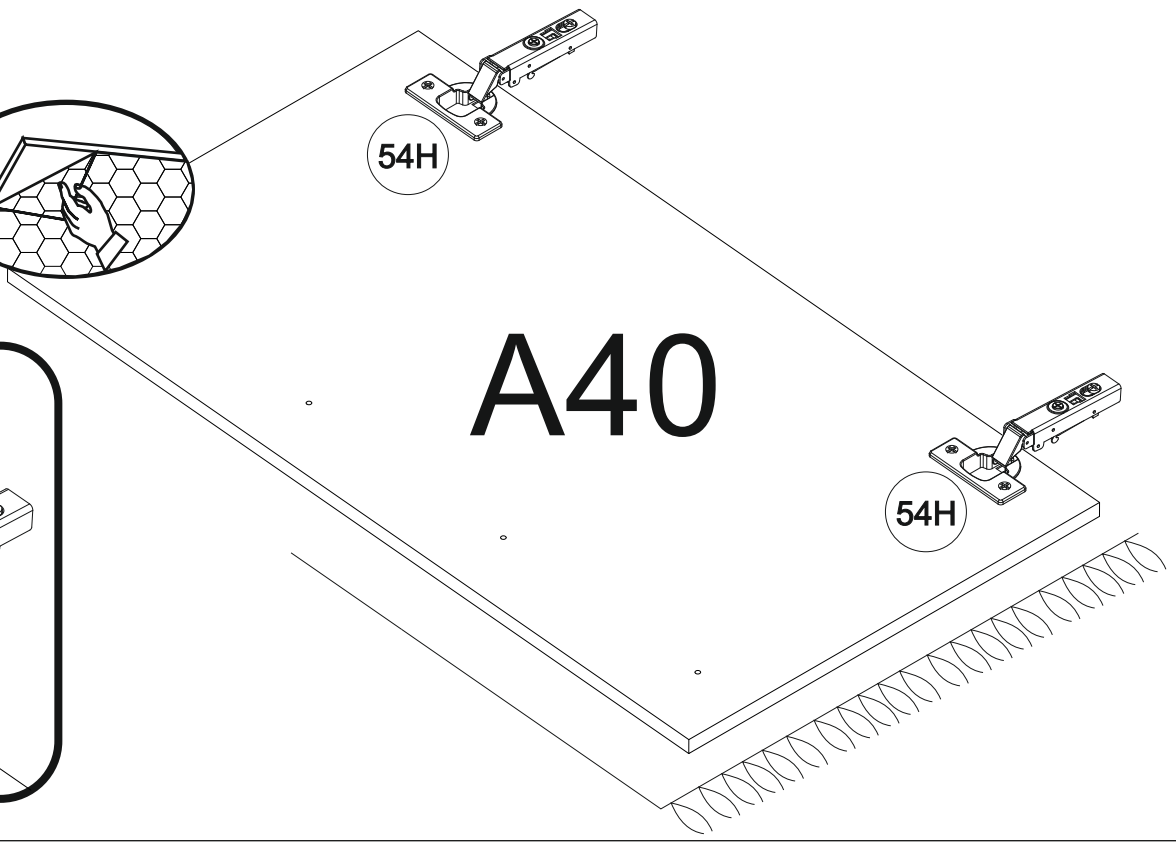
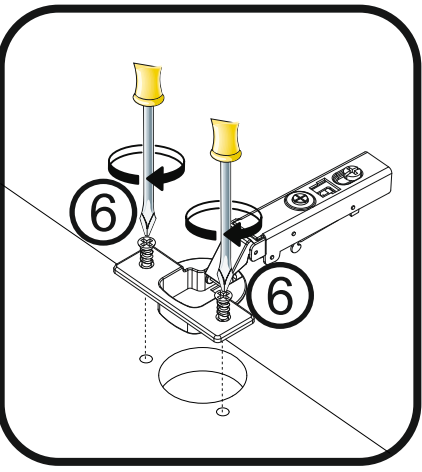
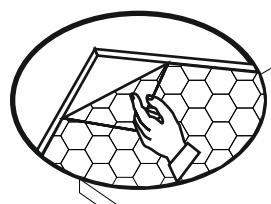
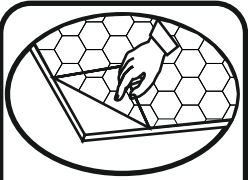
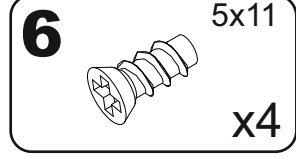
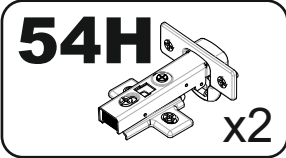
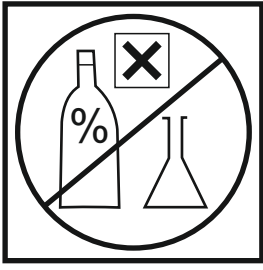

4

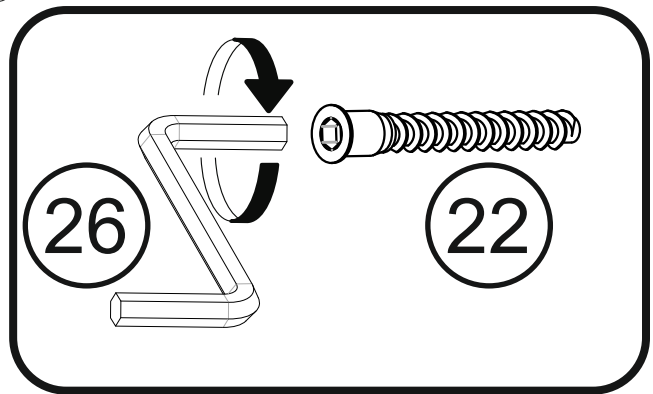
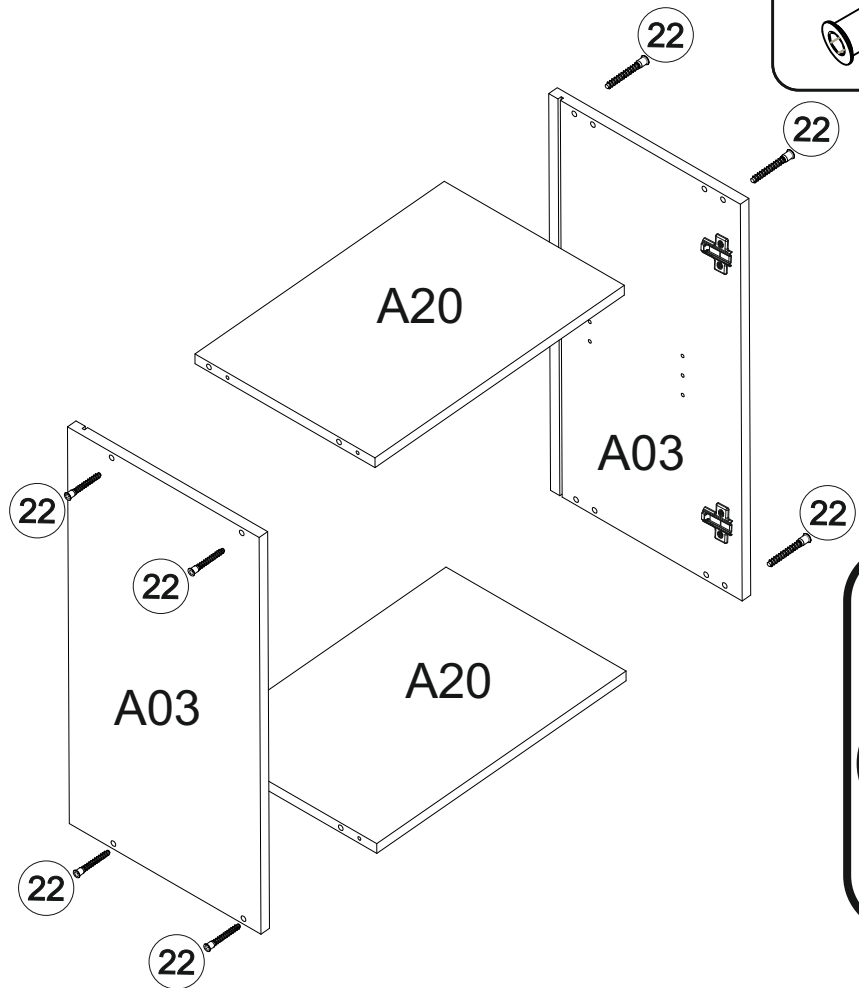
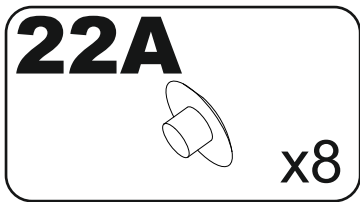
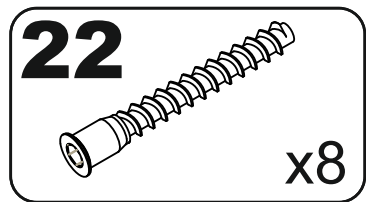

5

5

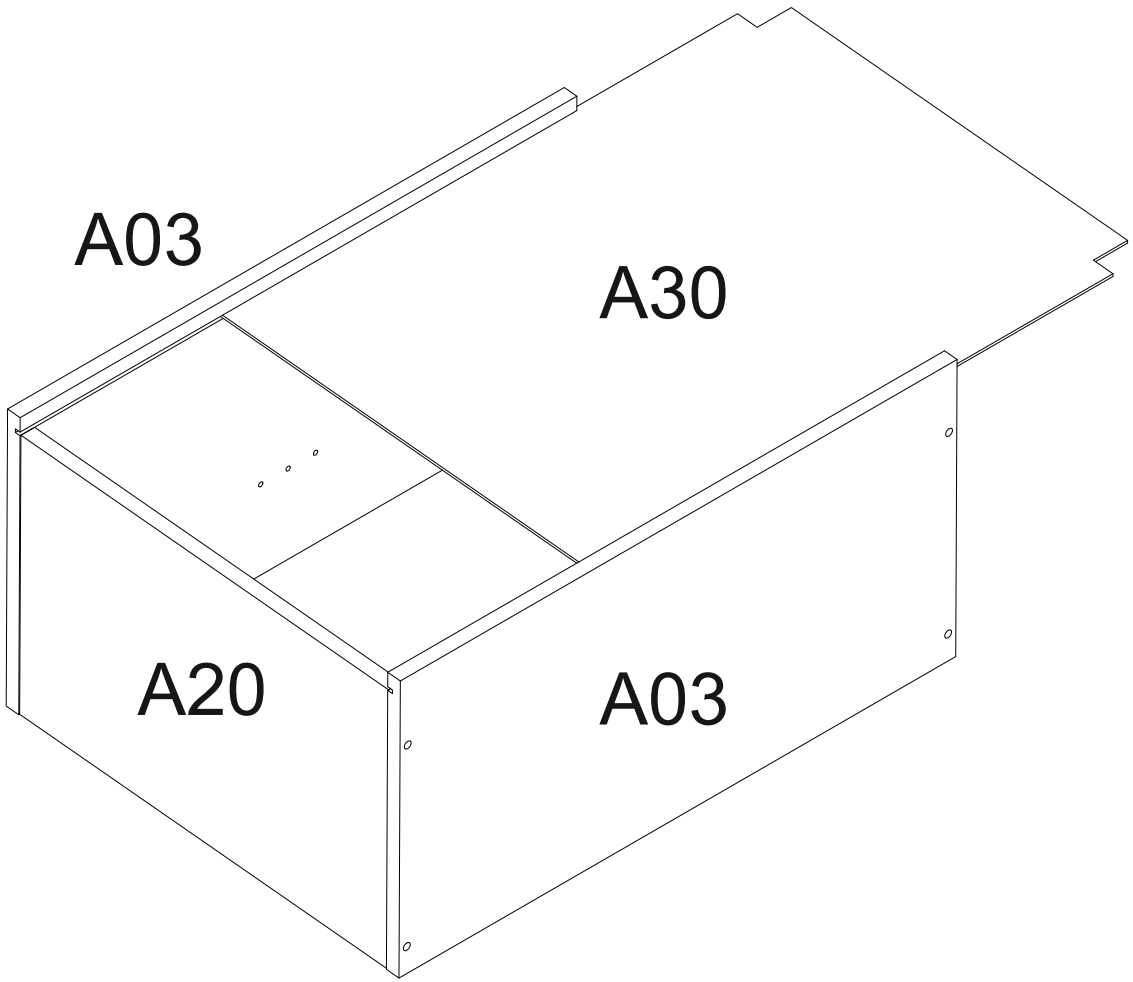

6

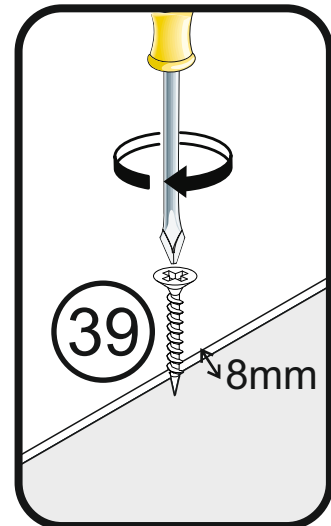
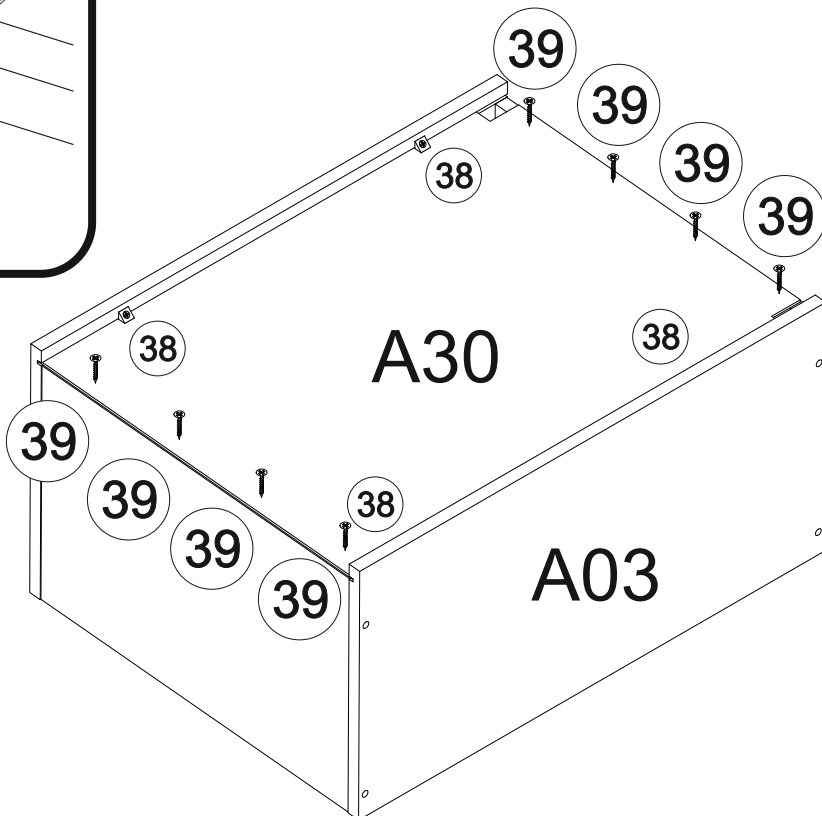
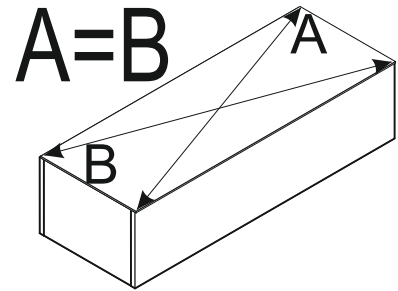
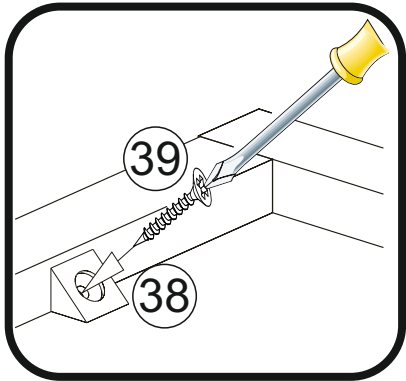
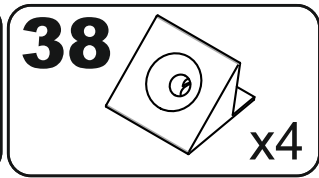
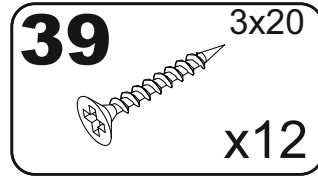

7

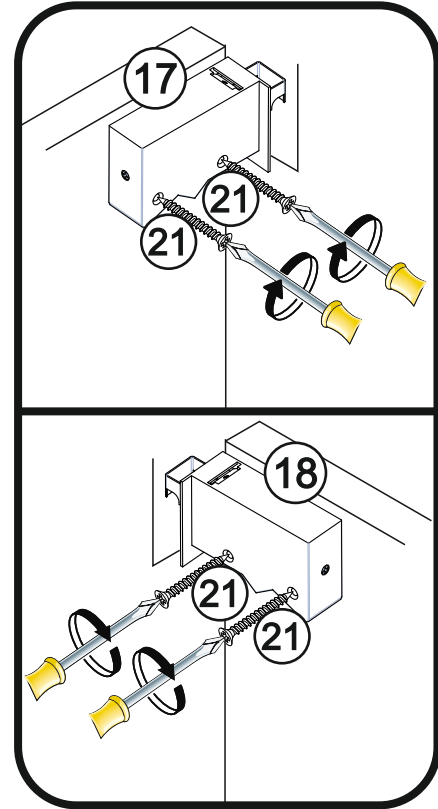
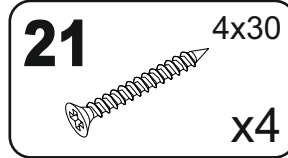
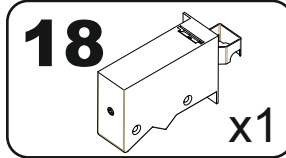
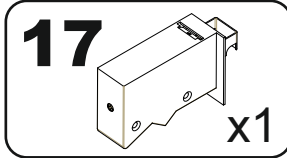
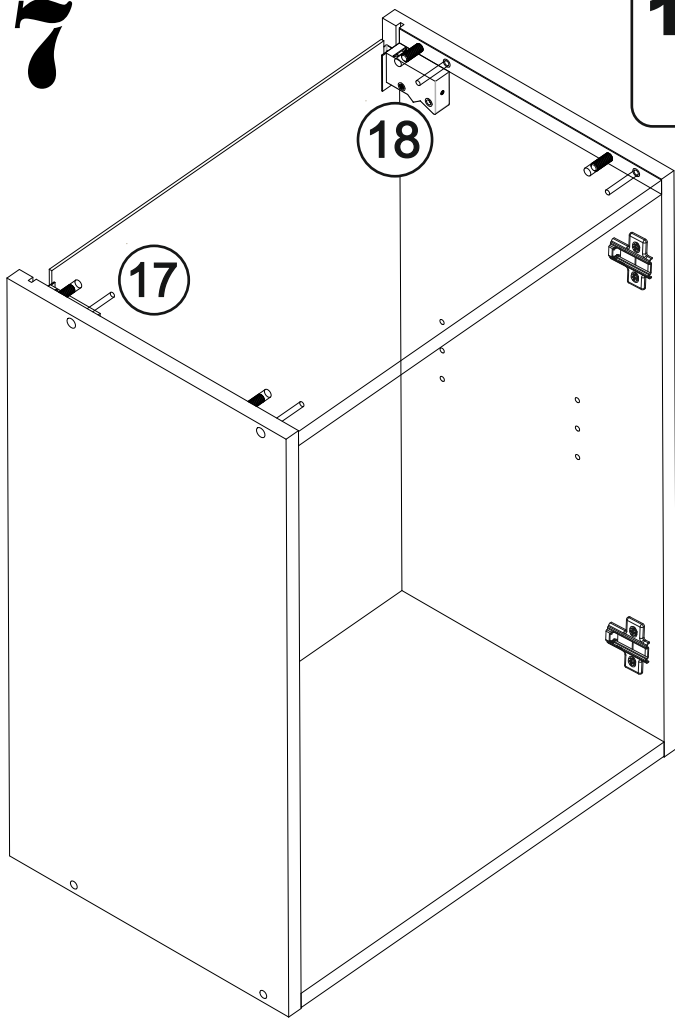

8

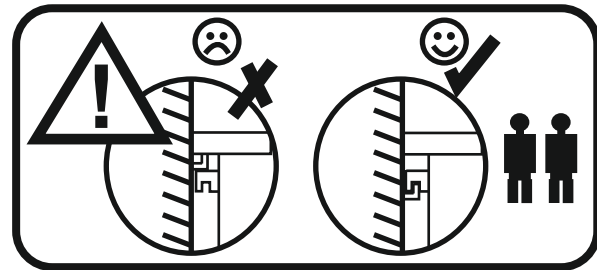
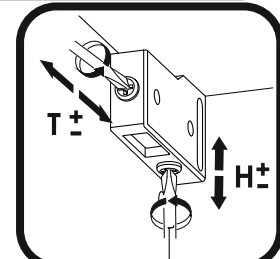
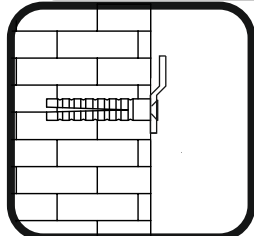
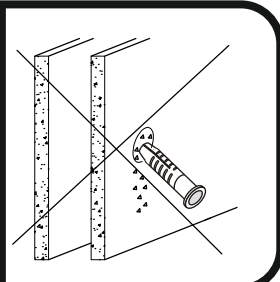
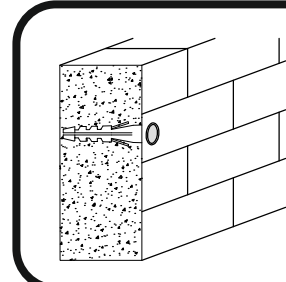
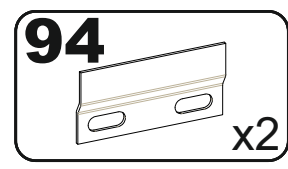
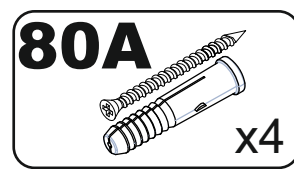
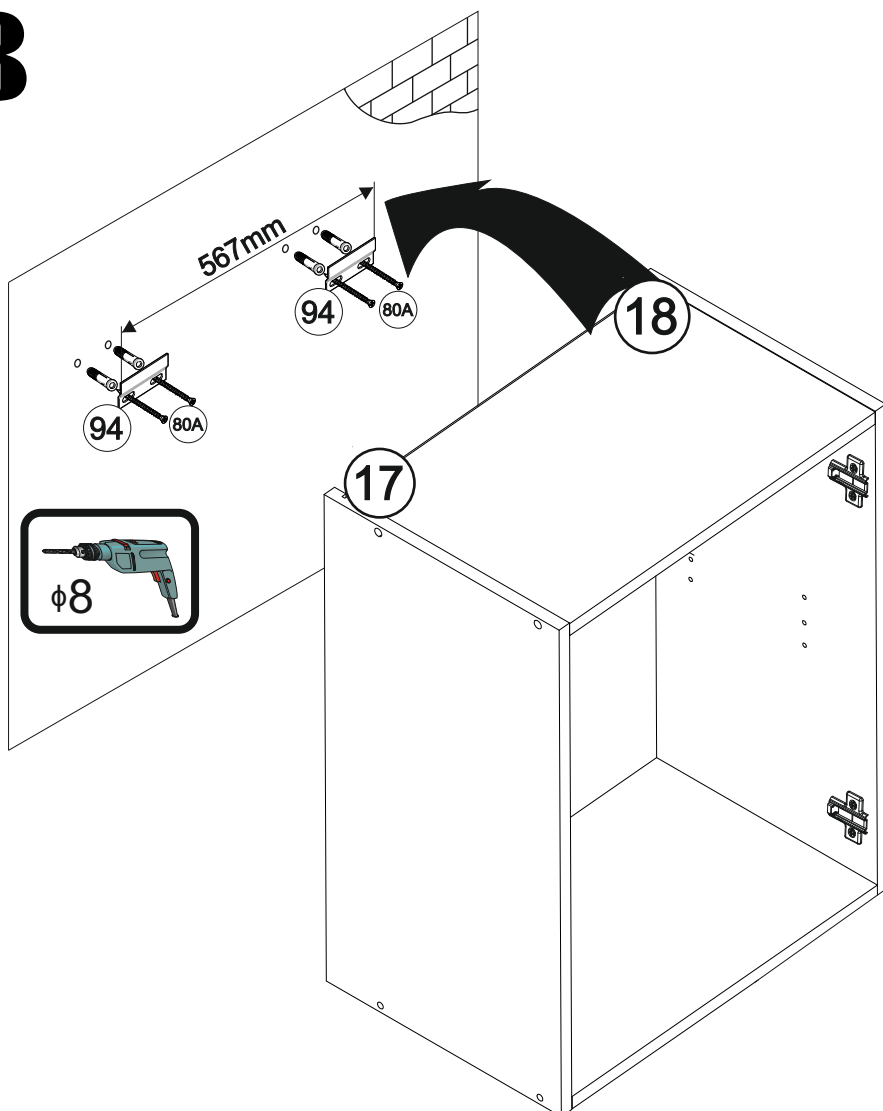

9

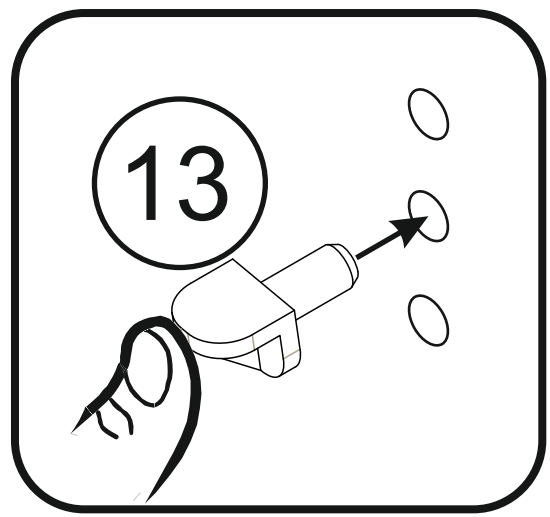
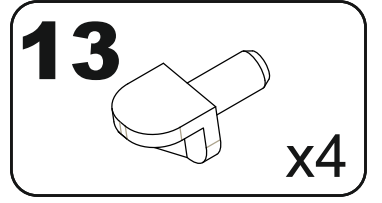
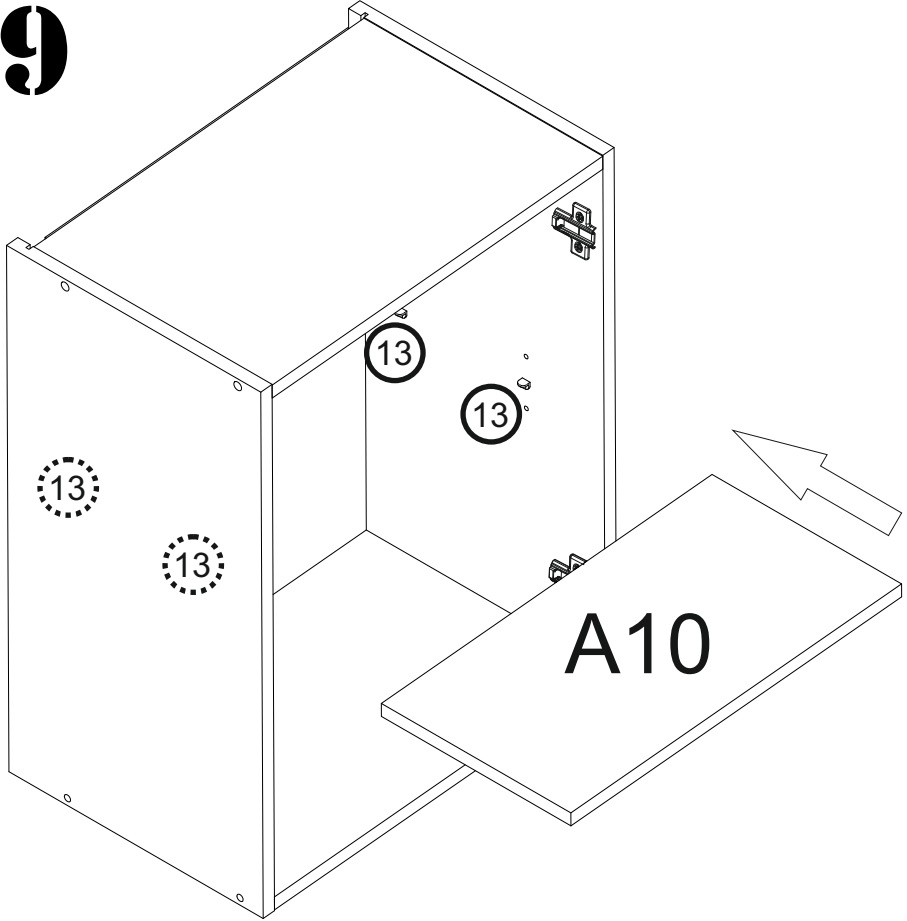

10

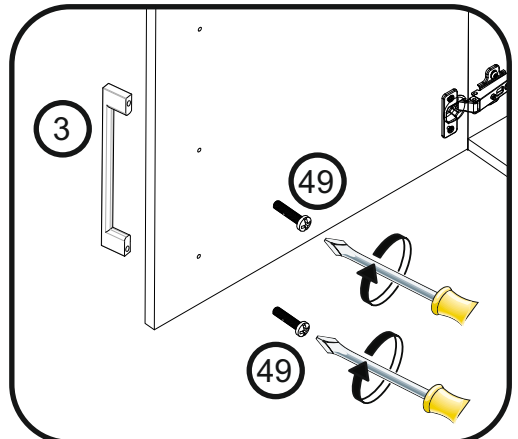
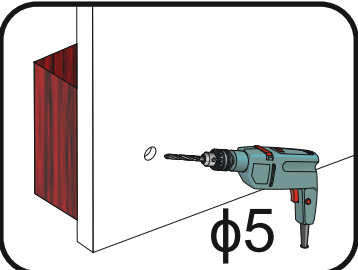
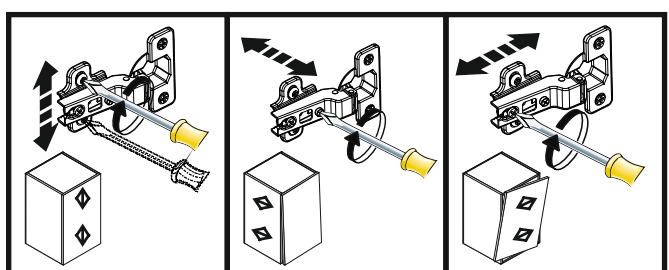
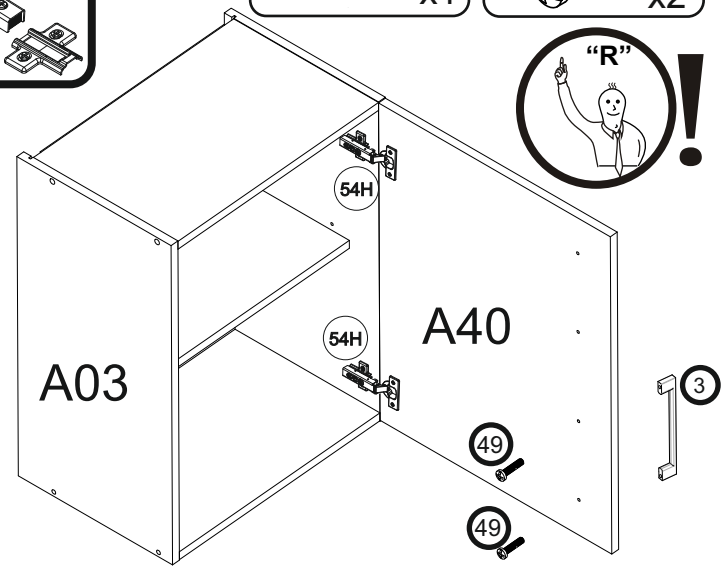
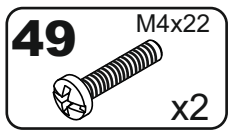
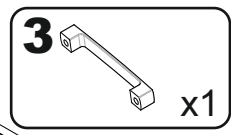
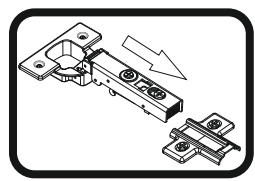
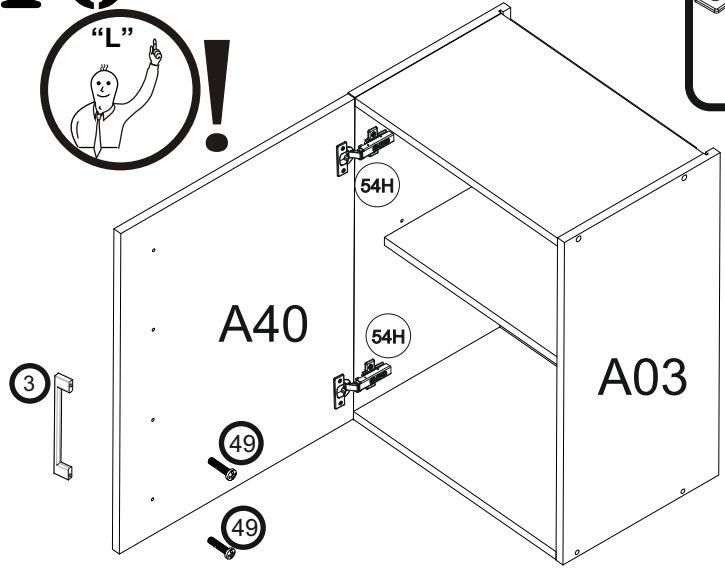

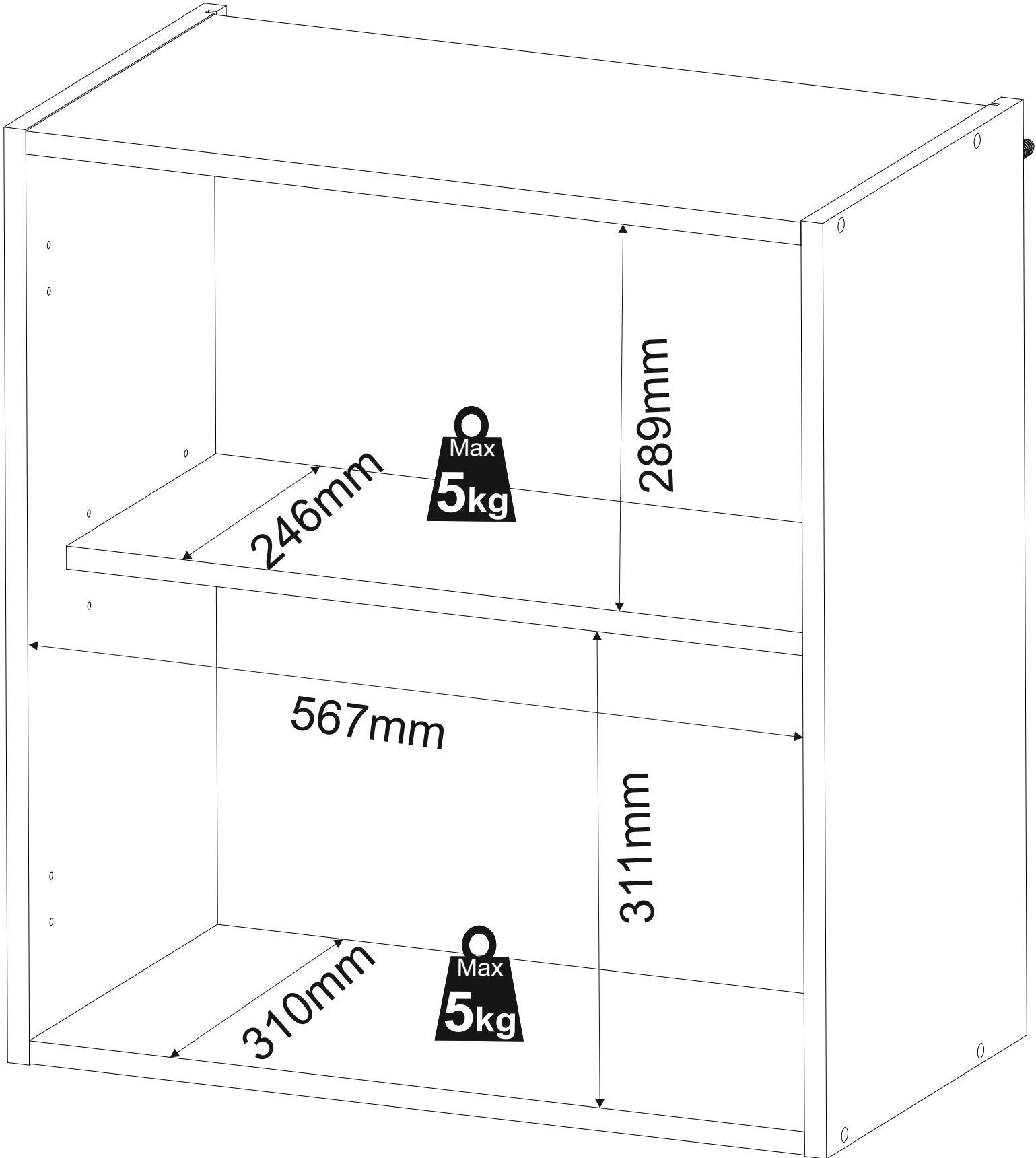
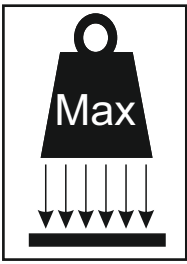

B x2

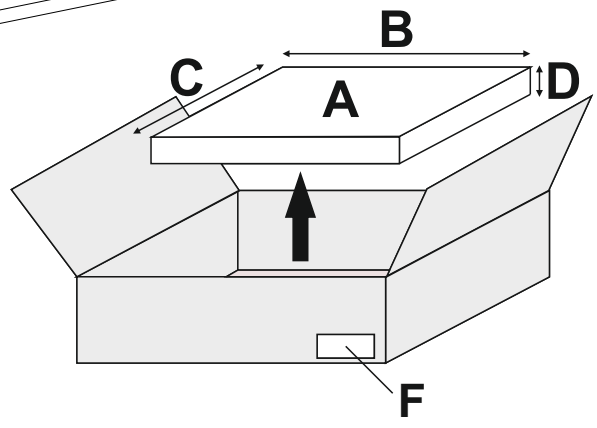
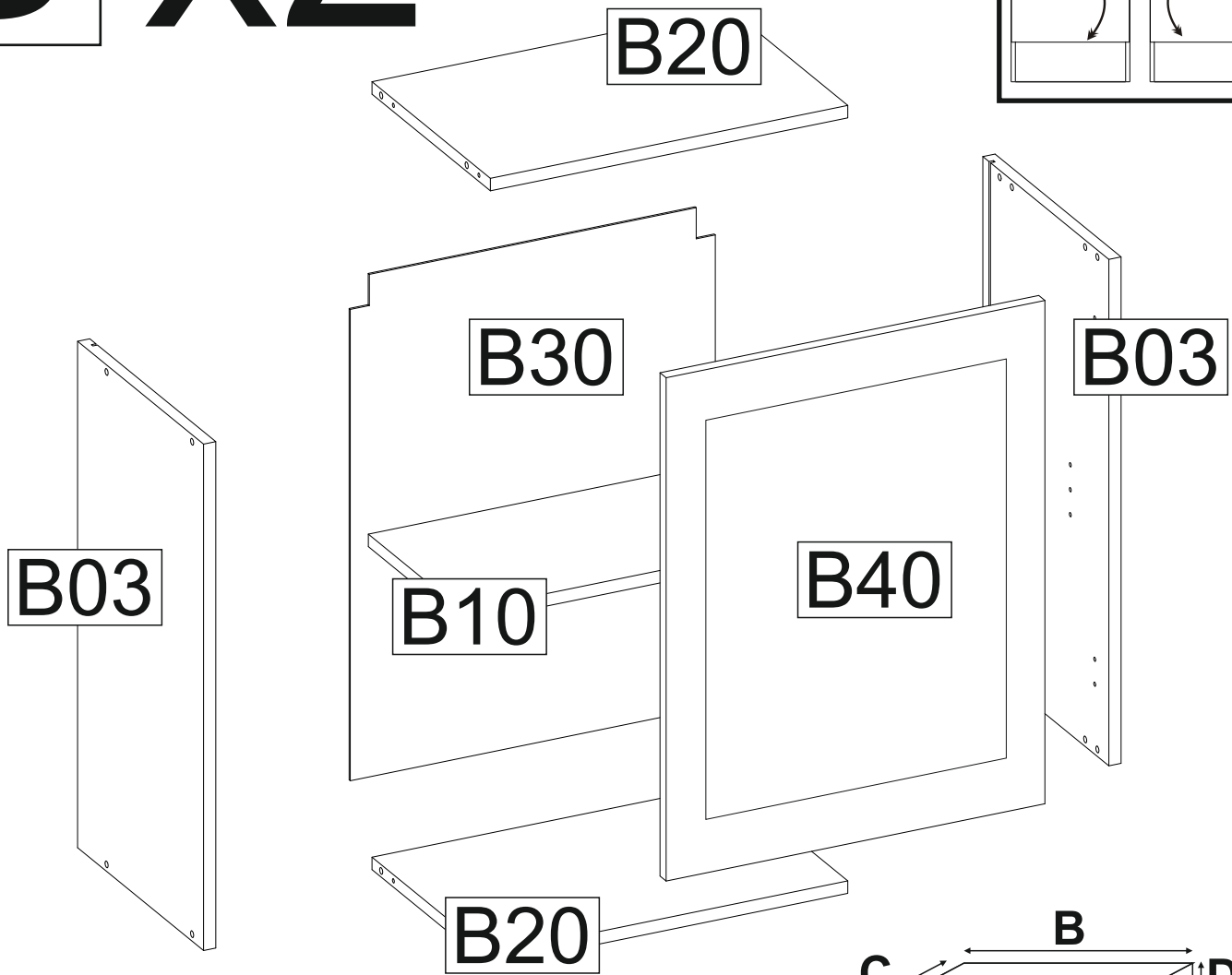
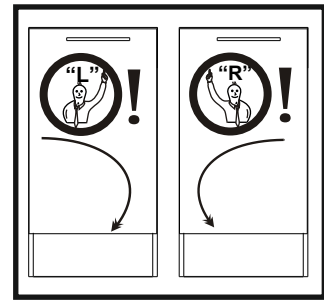

A	B_(mm)	C_(mm)	D_(mm)	E	F
B03	650	330	16	4	2 6
B10	467	246	16	2	2 6
B20	467	310	16	4	2 6
B30	644	477	3	2	2 6
B40	496	646	18	2	2 6

1

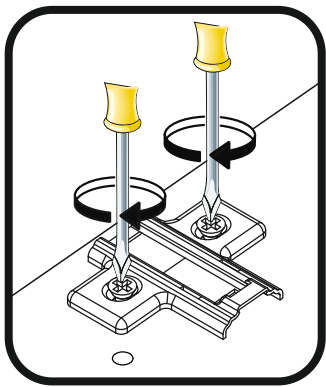
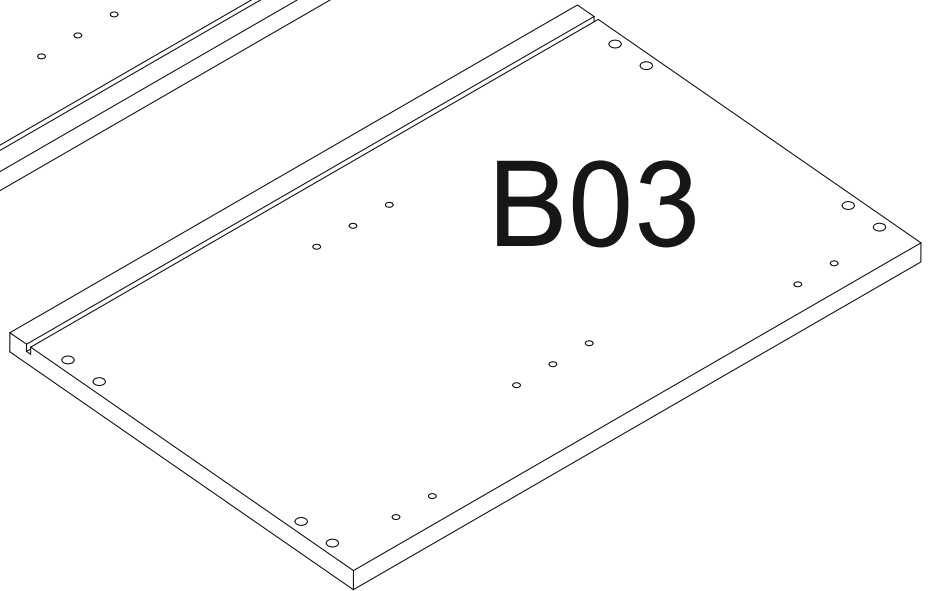
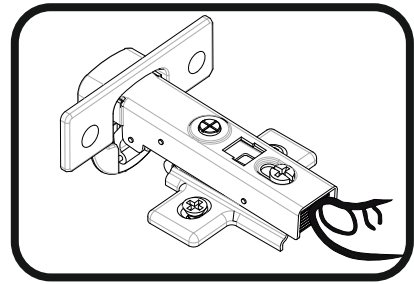
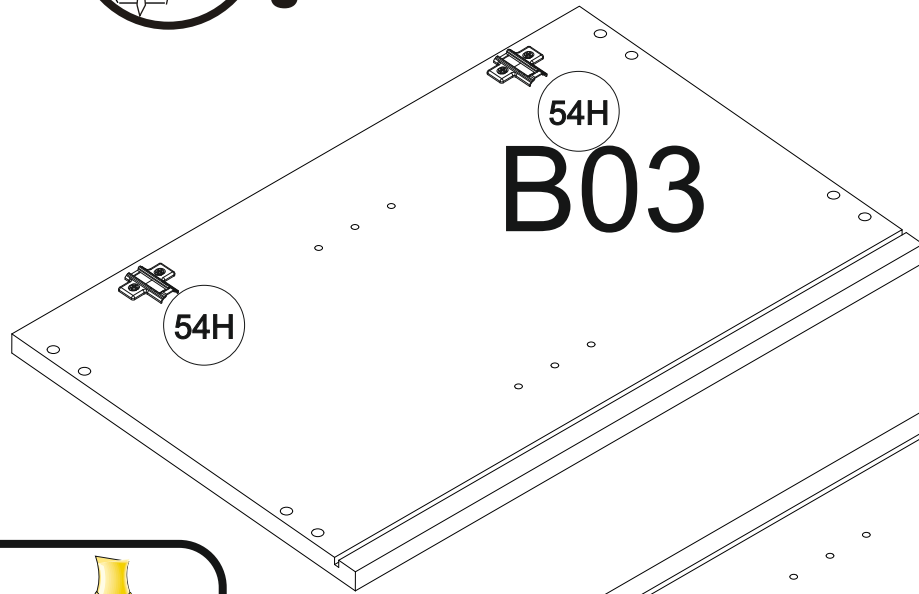
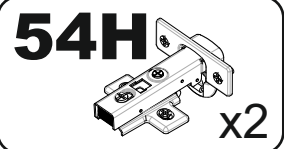

2

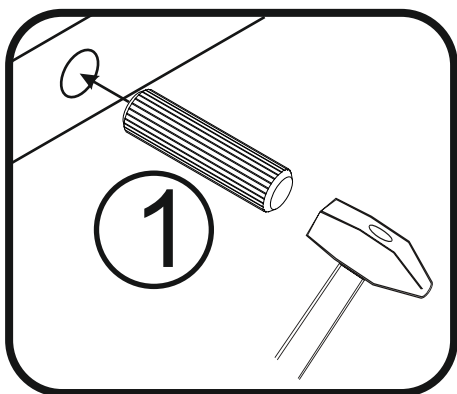
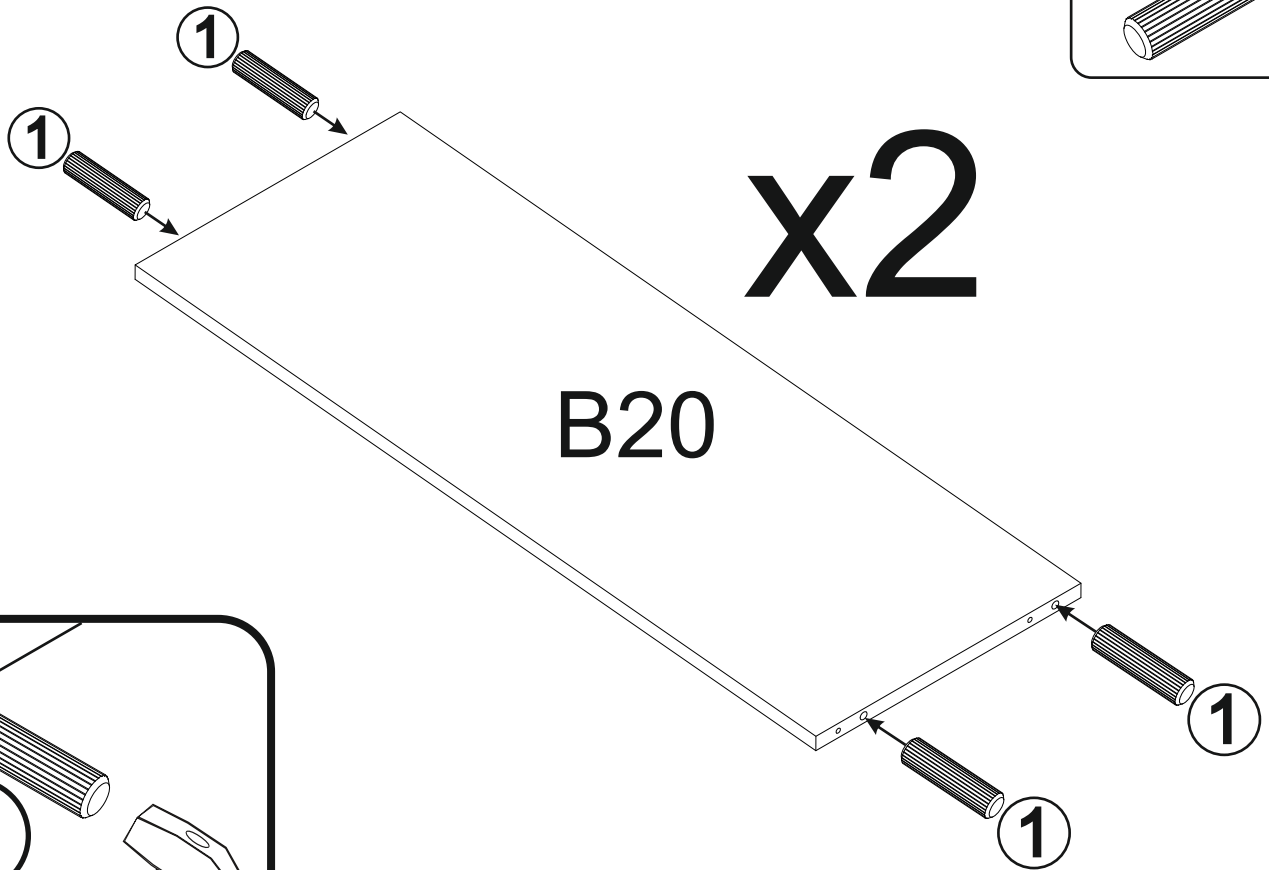
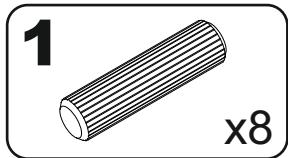

3

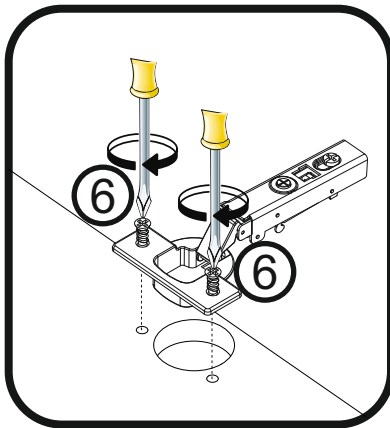
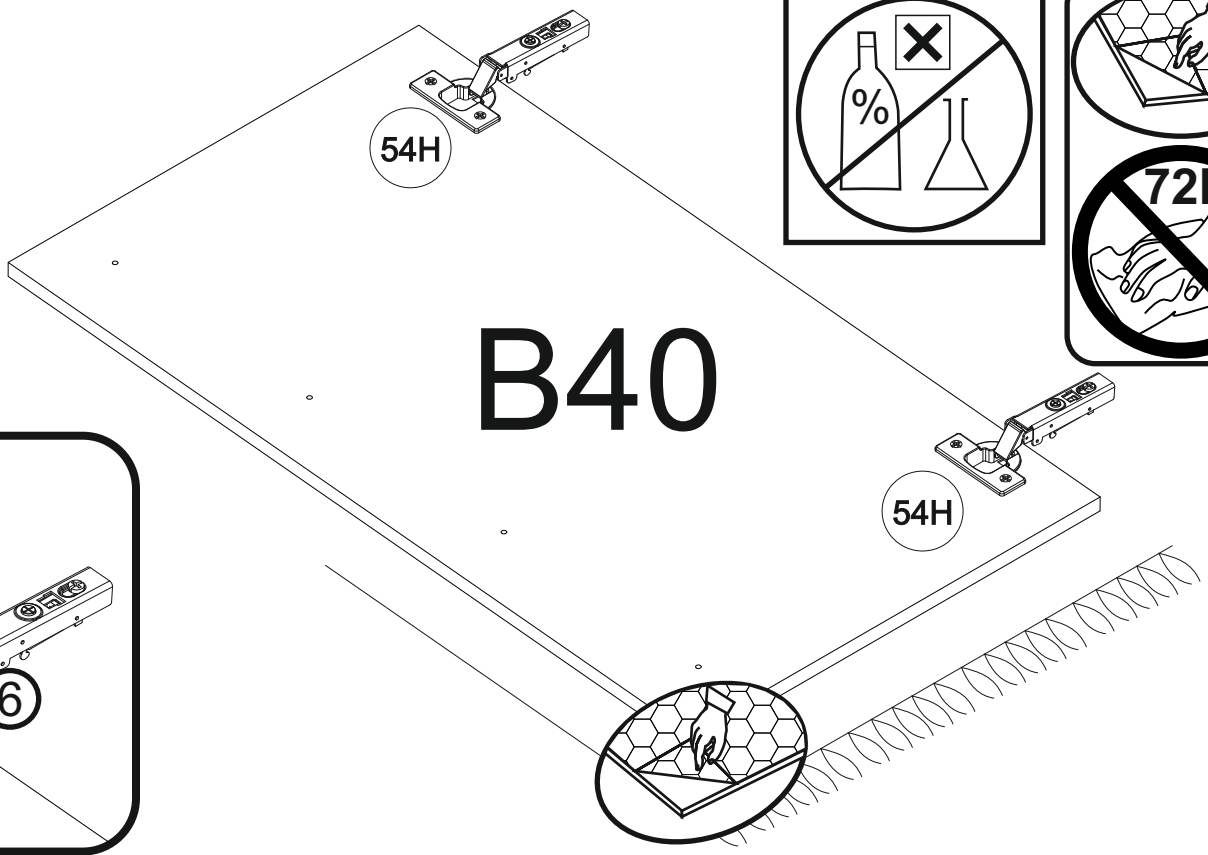
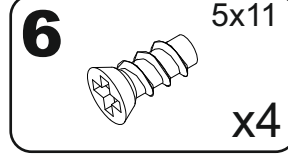
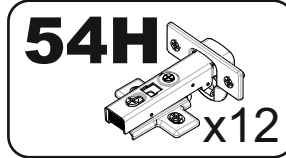

4

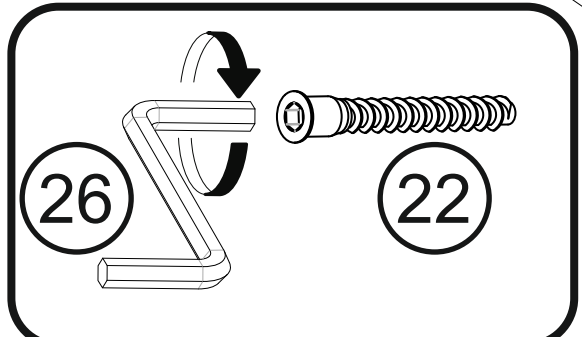
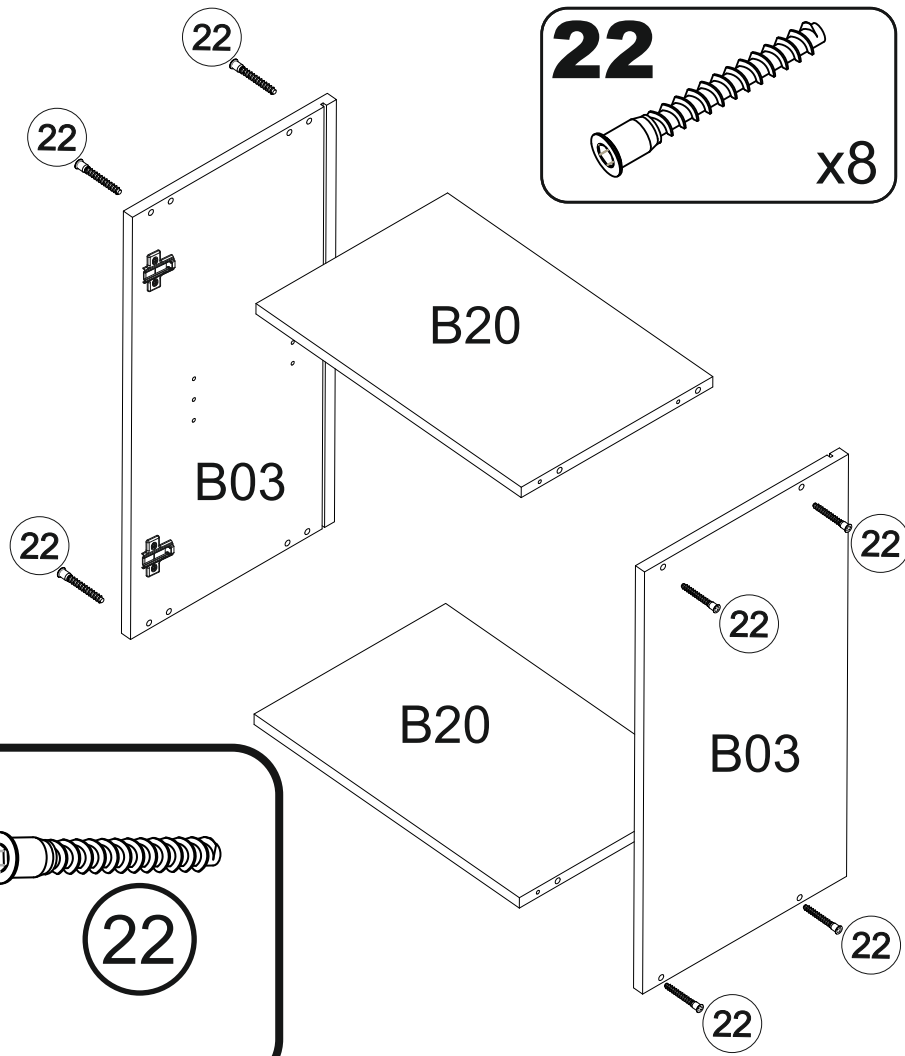
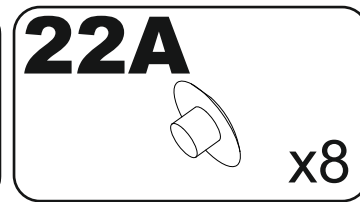
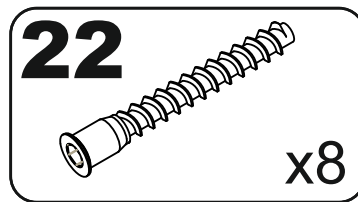

5

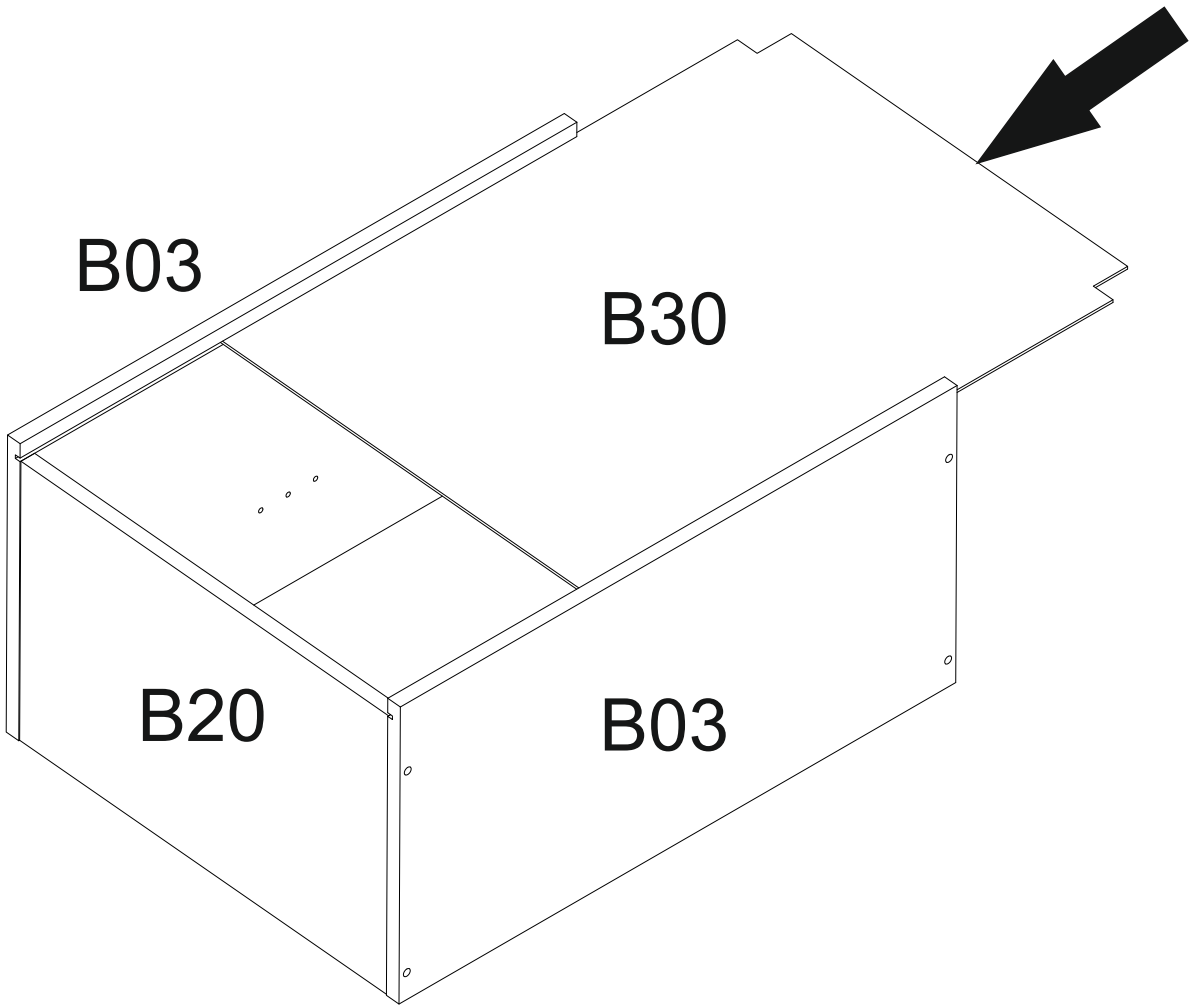

6

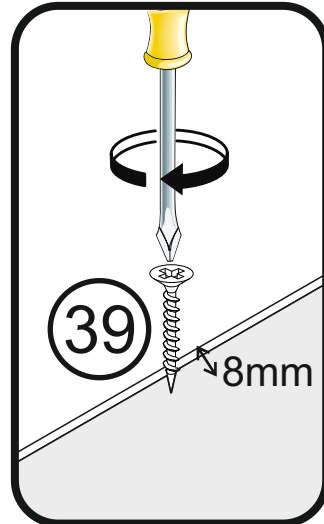
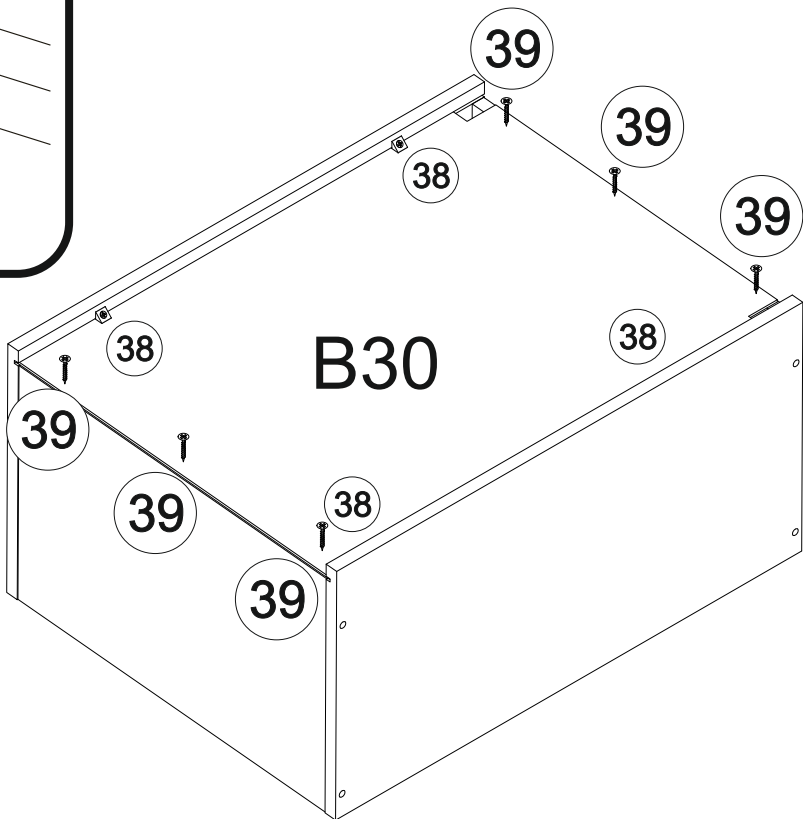
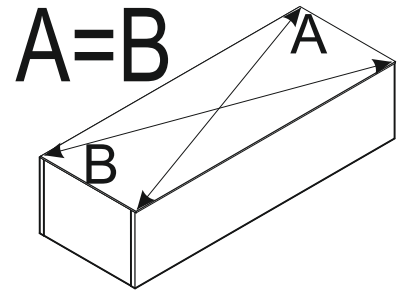
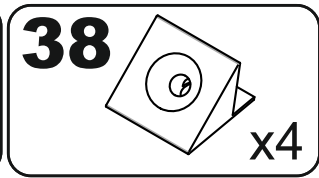
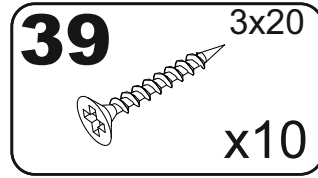
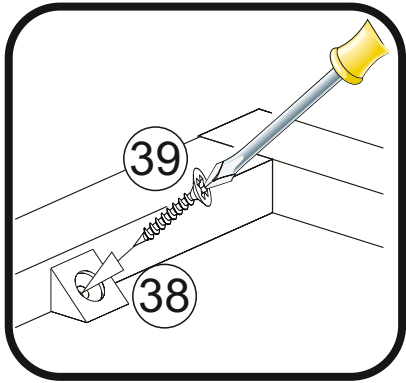

7

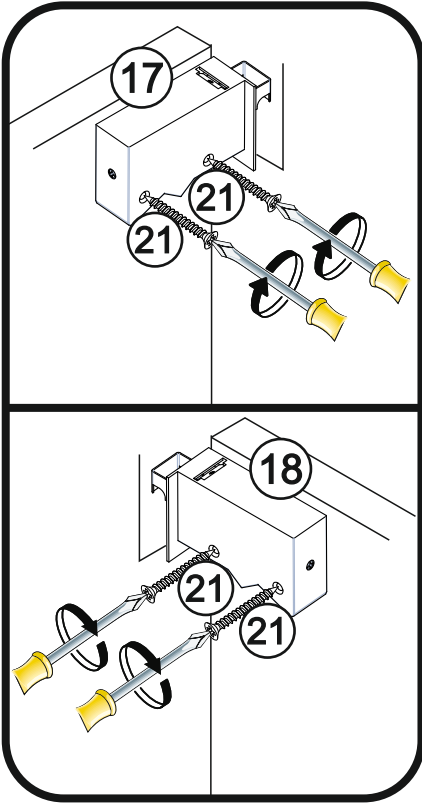
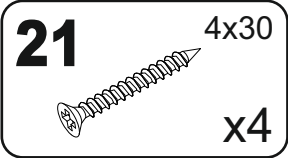
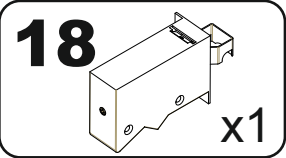
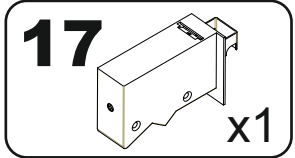
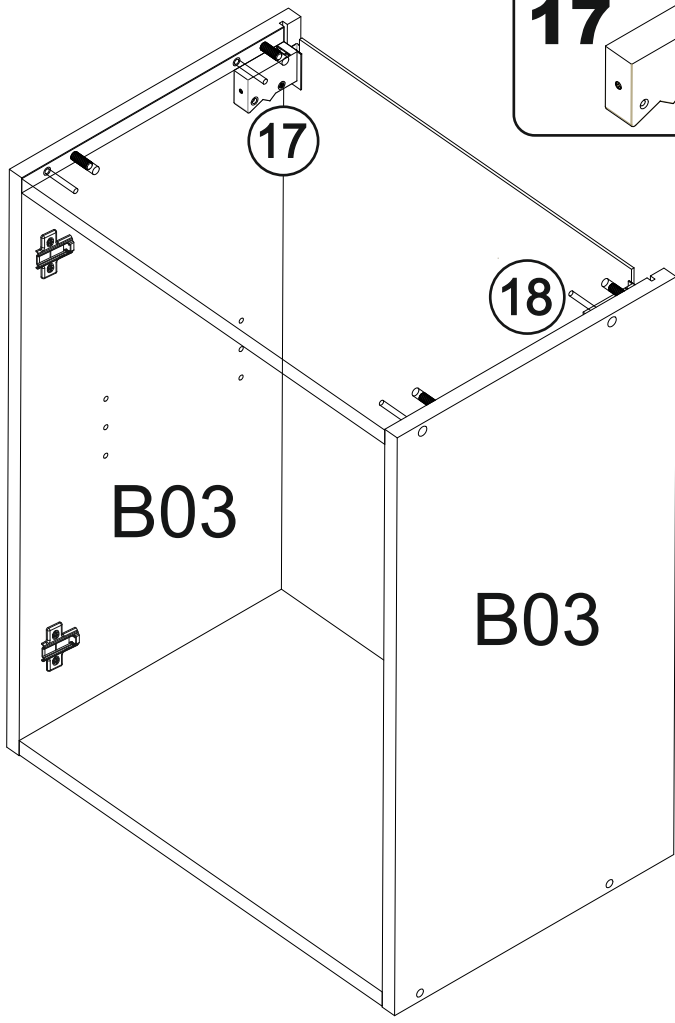

8

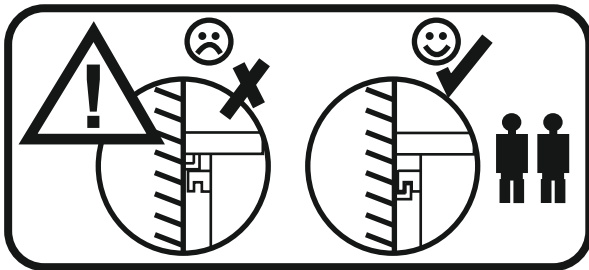
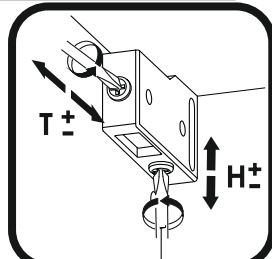
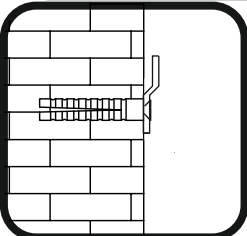
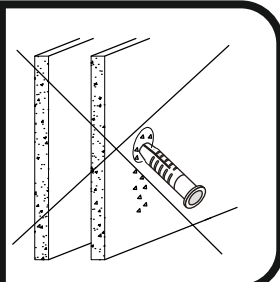
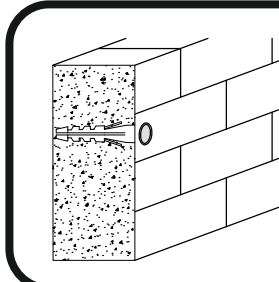
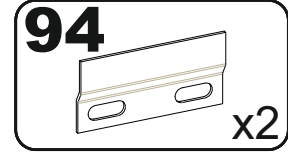
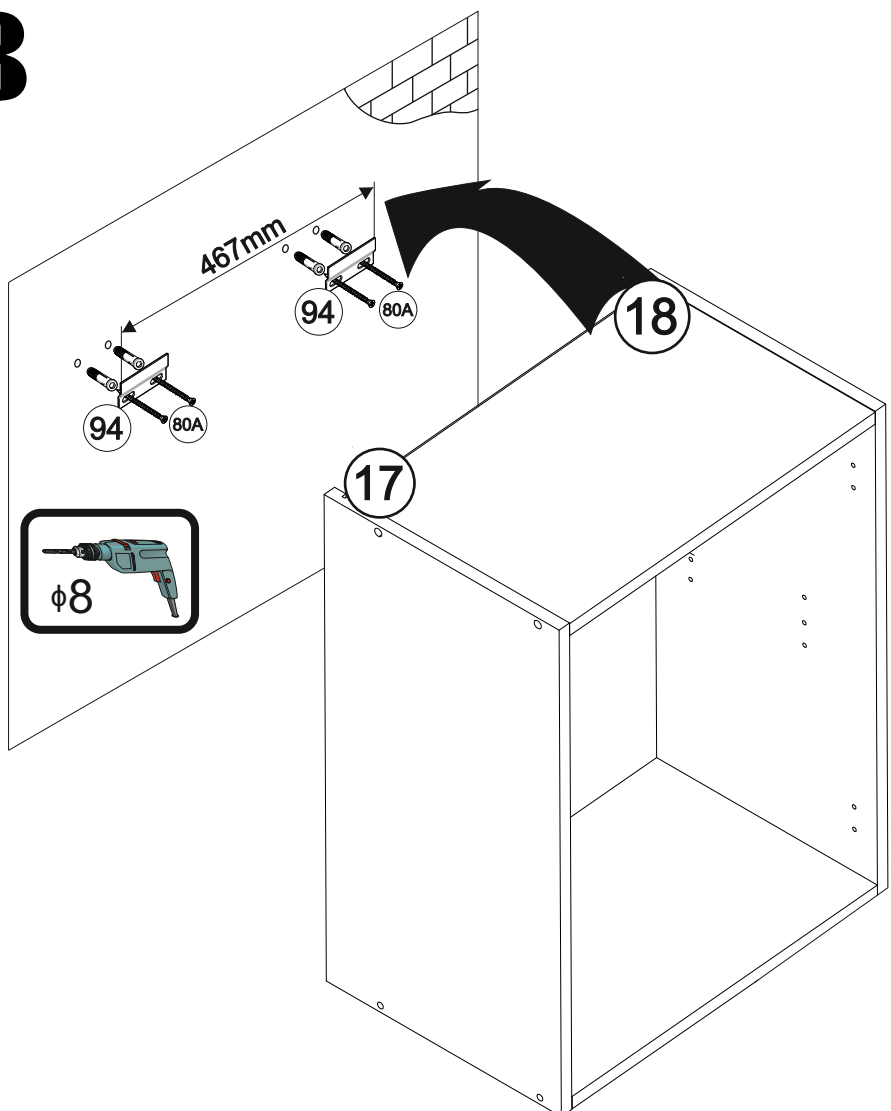

9

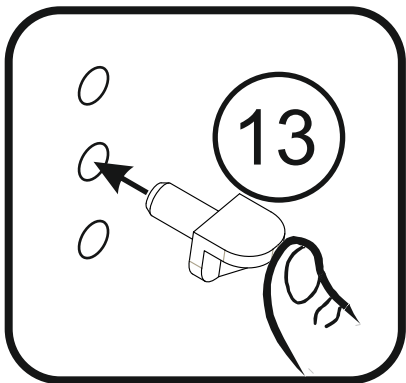
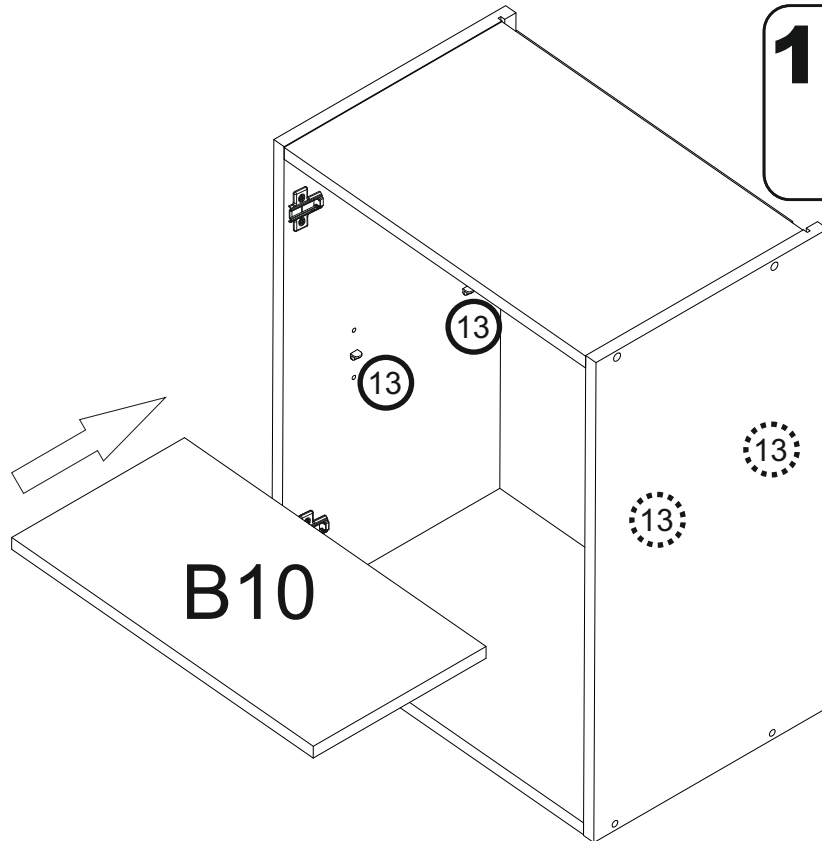
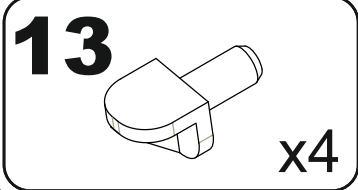

10

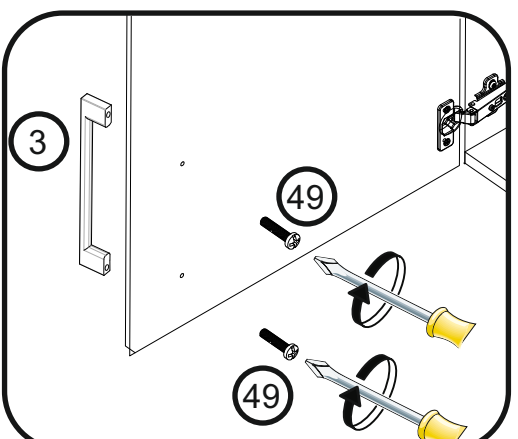
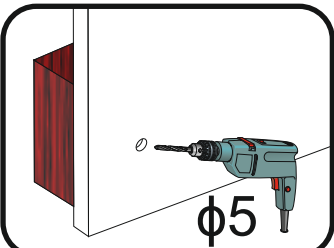
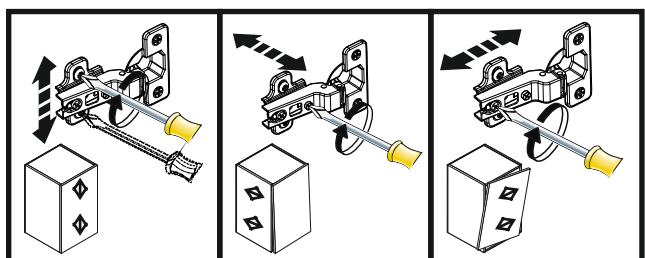
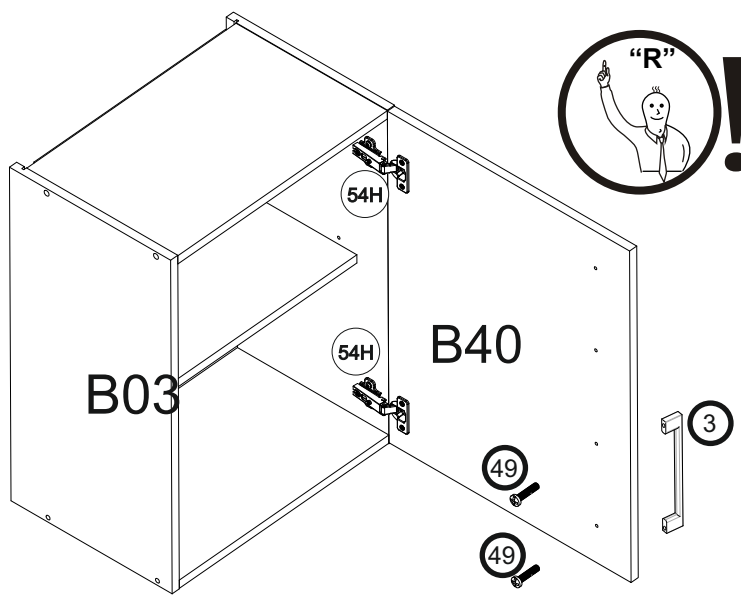
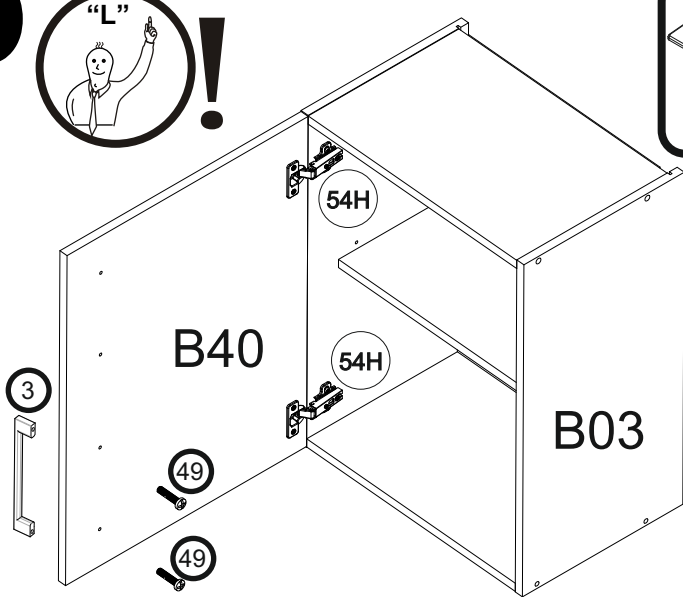
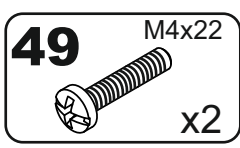
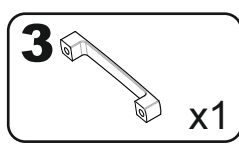
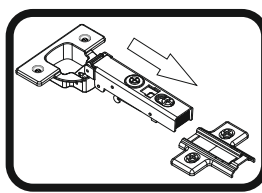

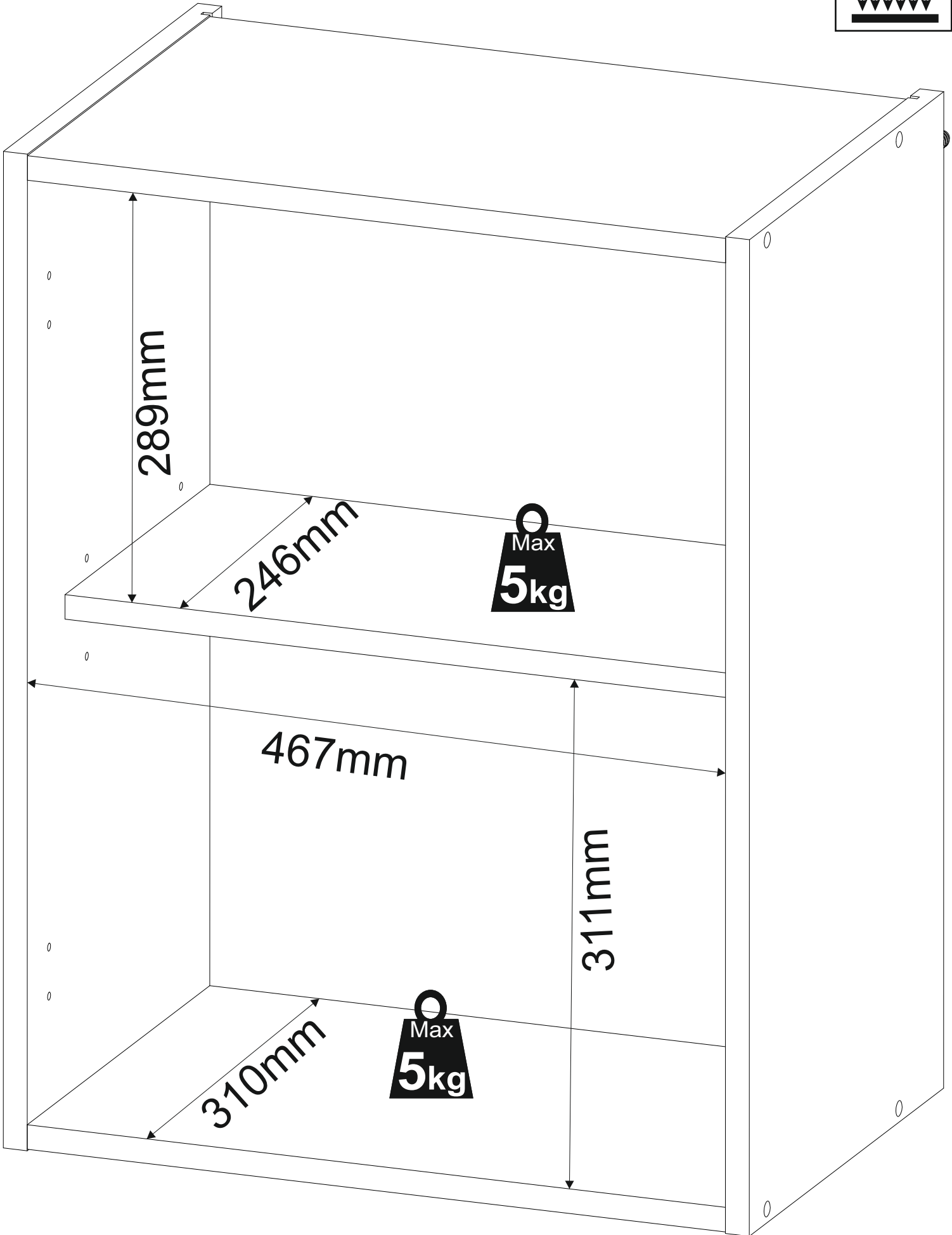
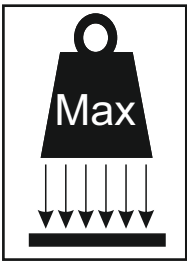

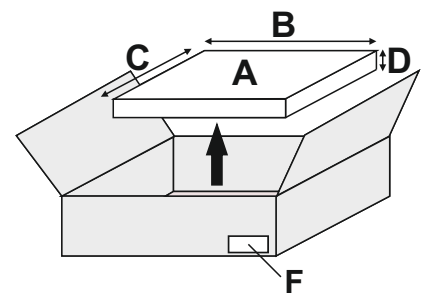
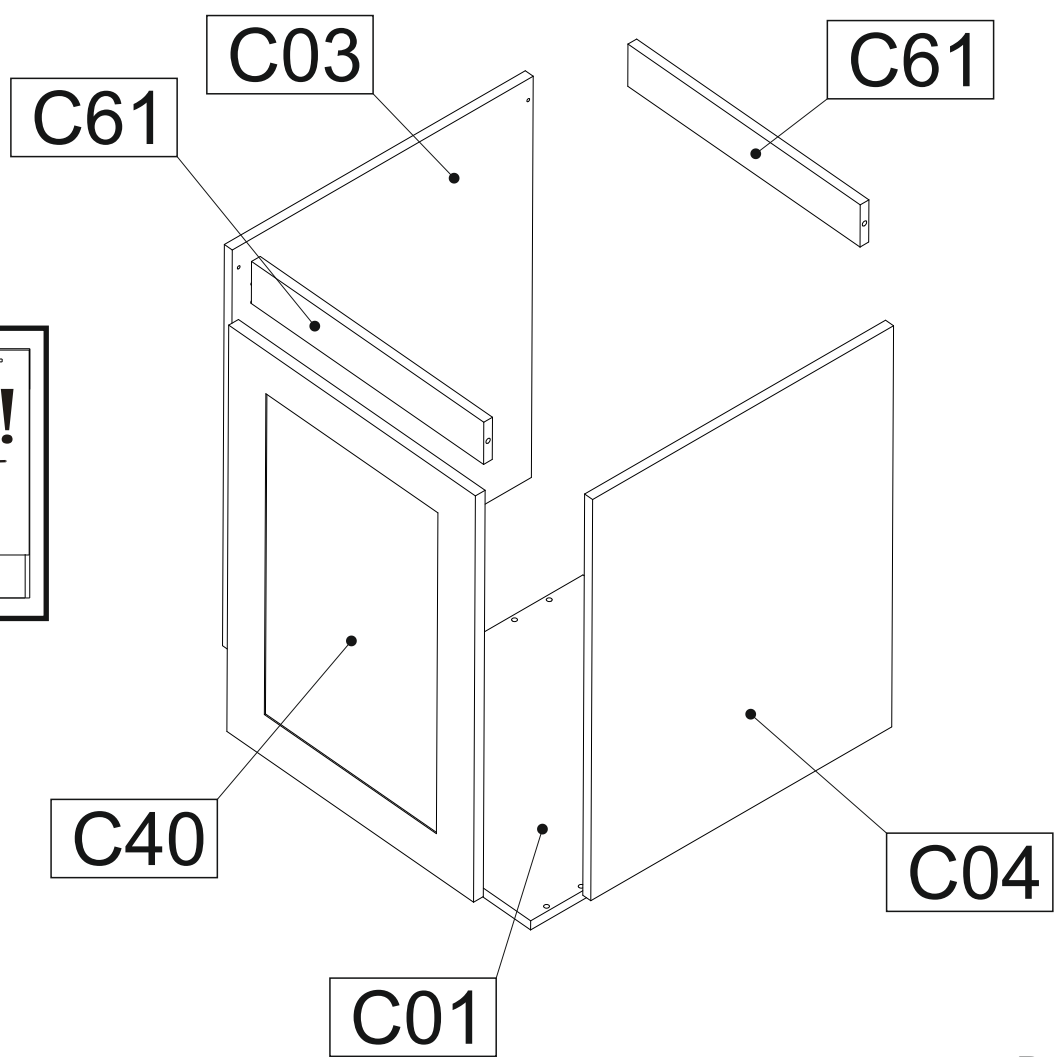
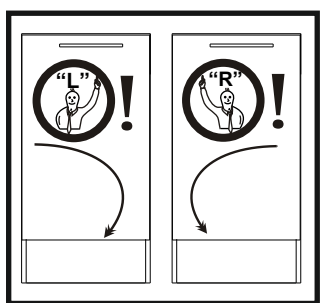
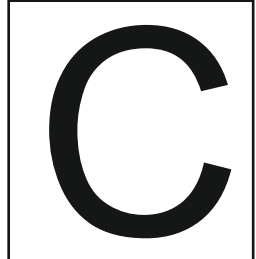

A	B_(mm)	C_(mm)	D_(mm)	E	F
C01	500	555	16	1	4 6
C03	704	555	16	1	4 6
C04	704	555	16	1	4 6
C40	713	496	18	1	4 6
C61	467	74	16	2	4 6

1

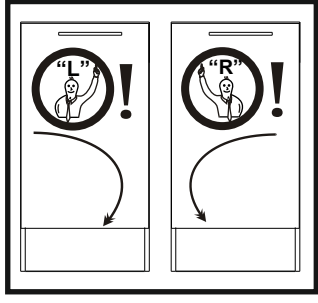

C

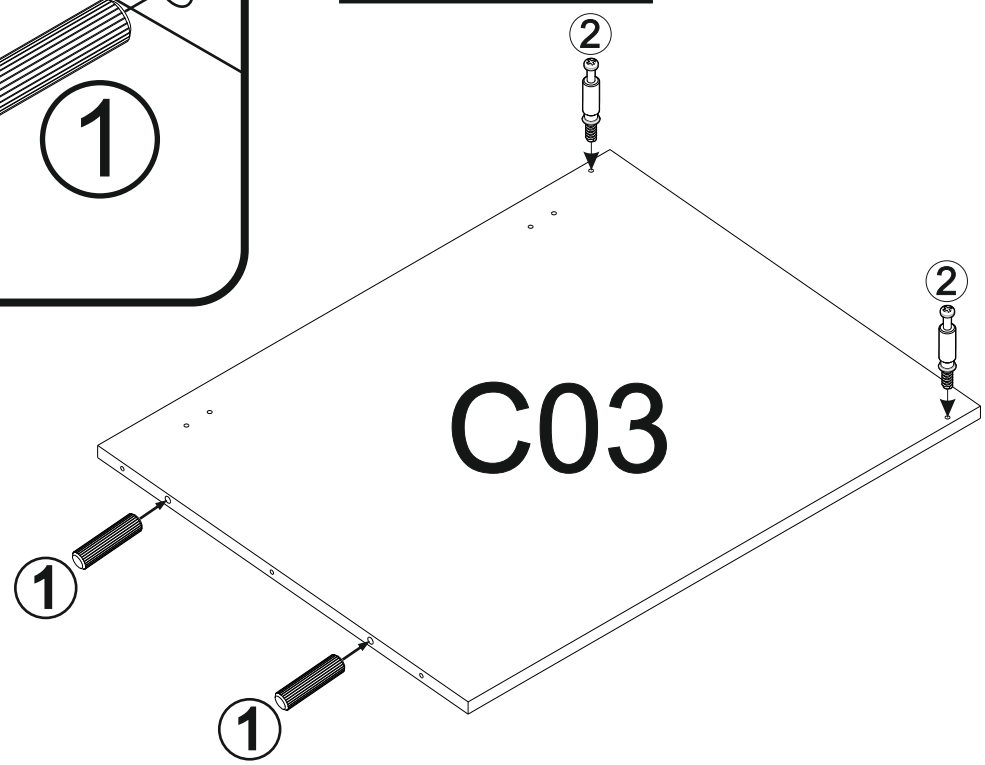
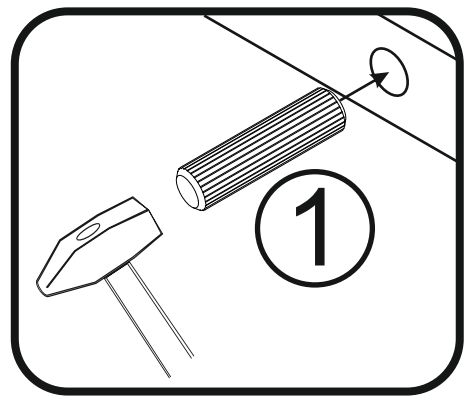
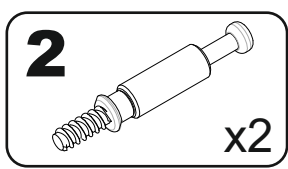
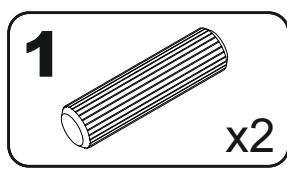

C03

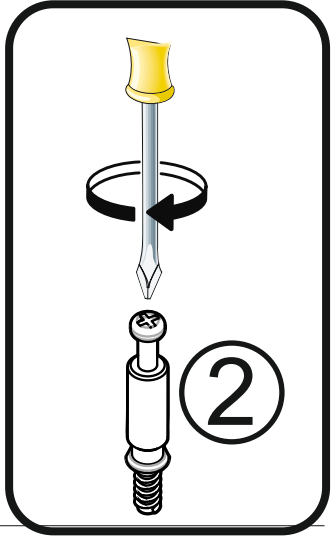

2

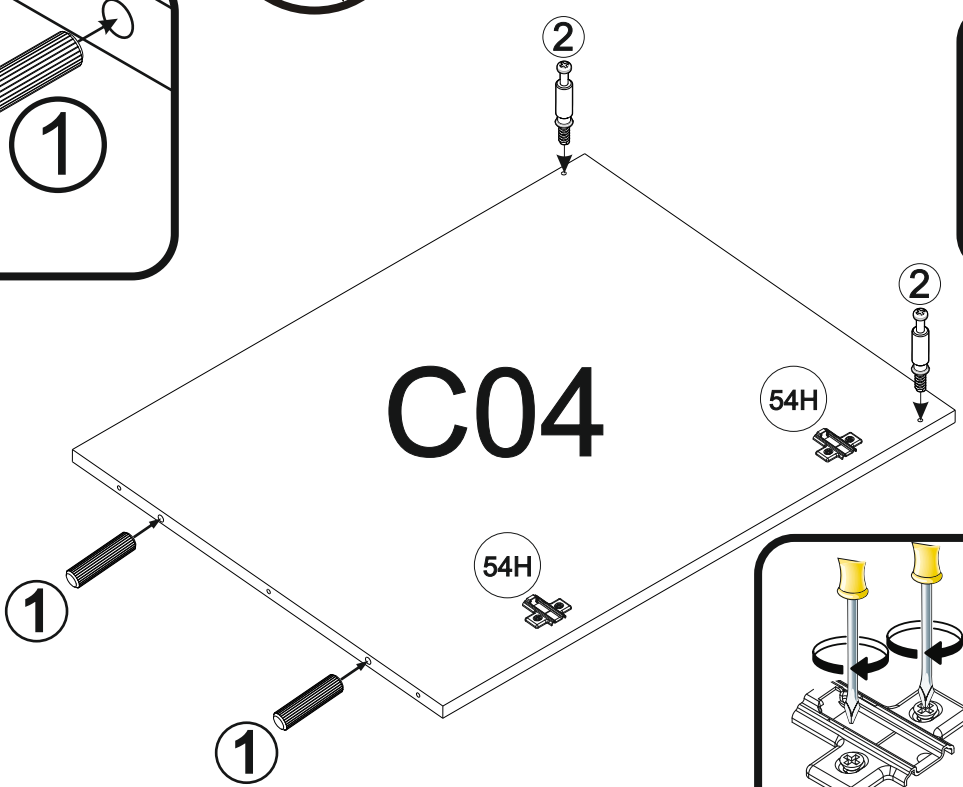
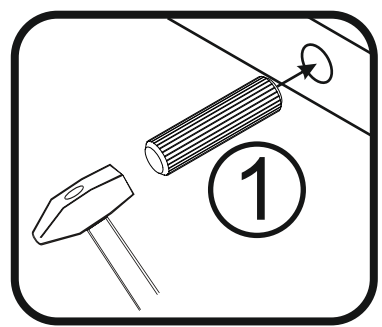
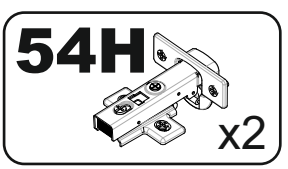
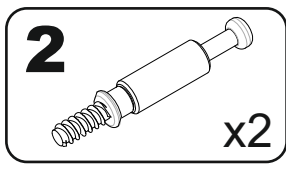
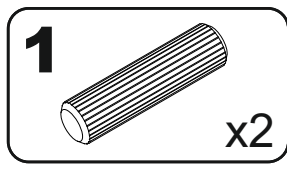

C04

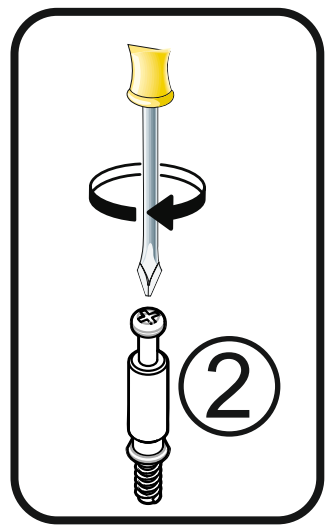
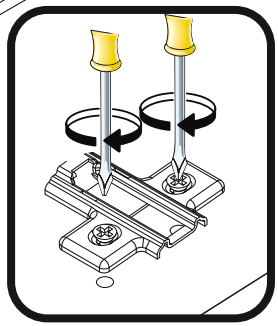
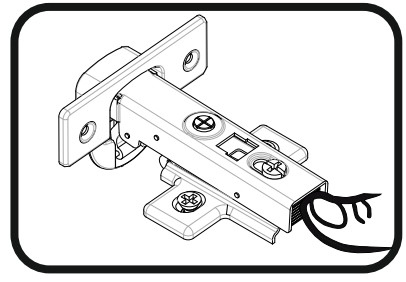

3

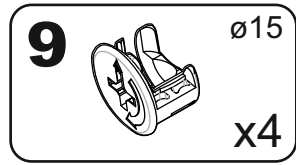
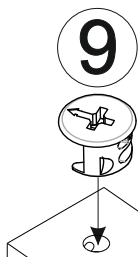

C61

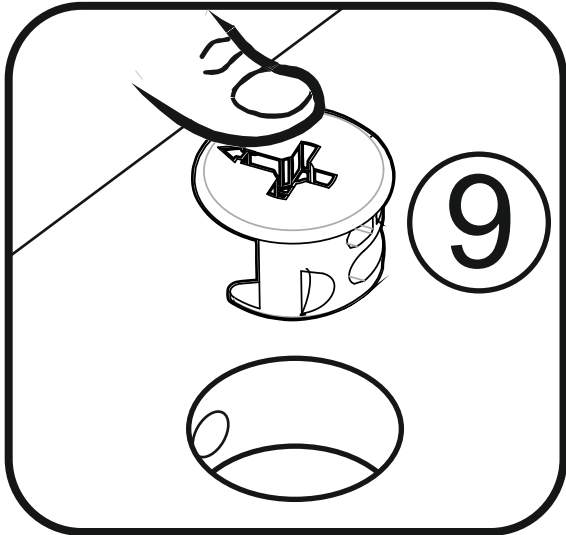

x2

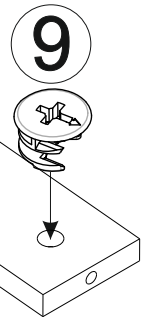

4

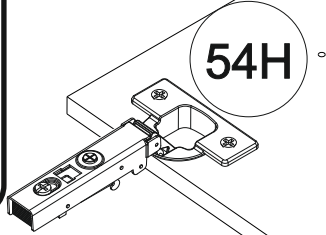
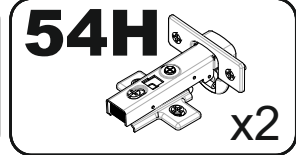
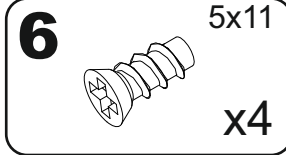
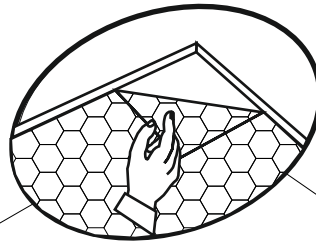
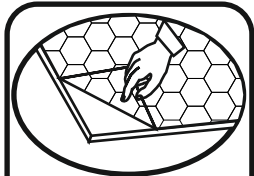

C40

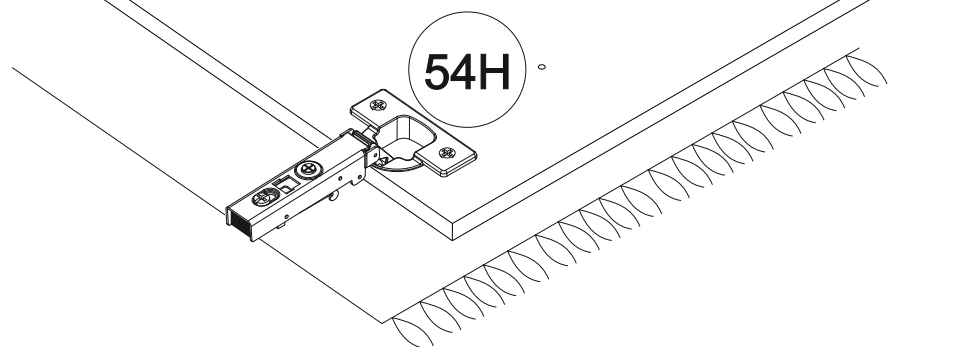
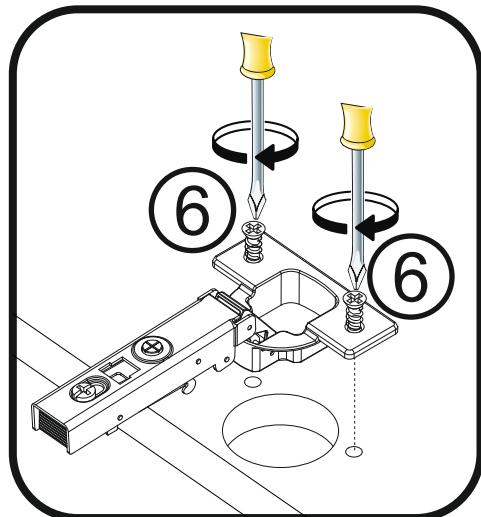

5

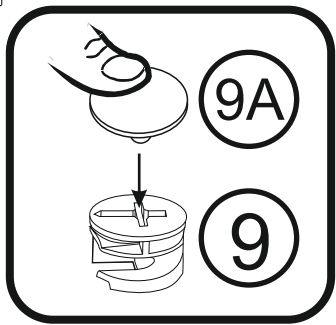
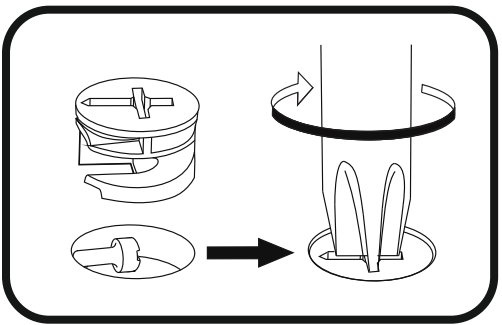
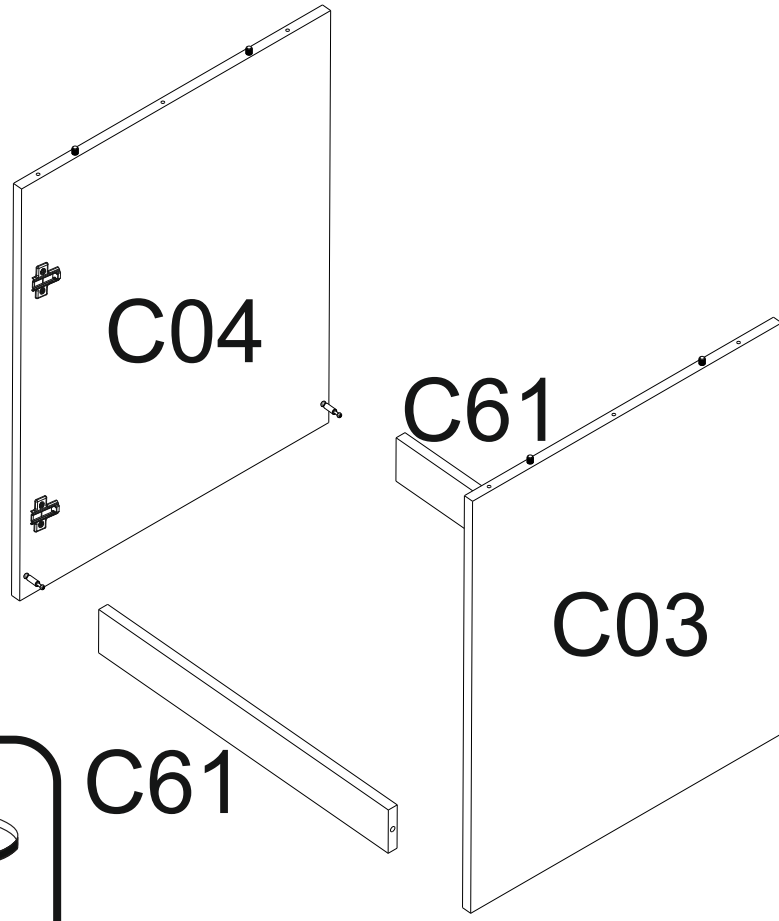
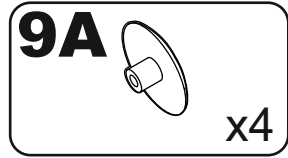

6

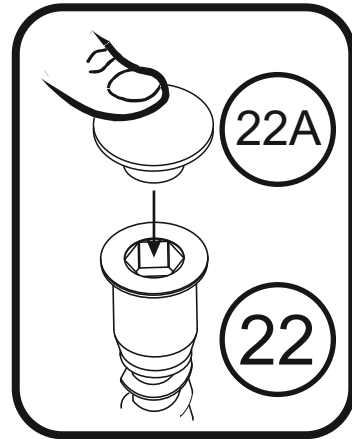
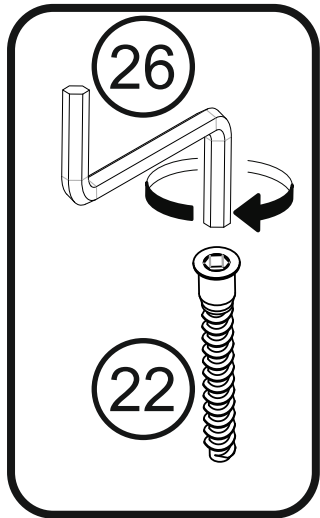
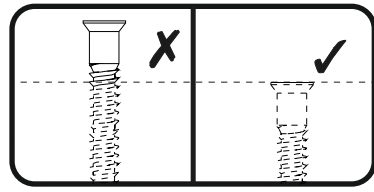
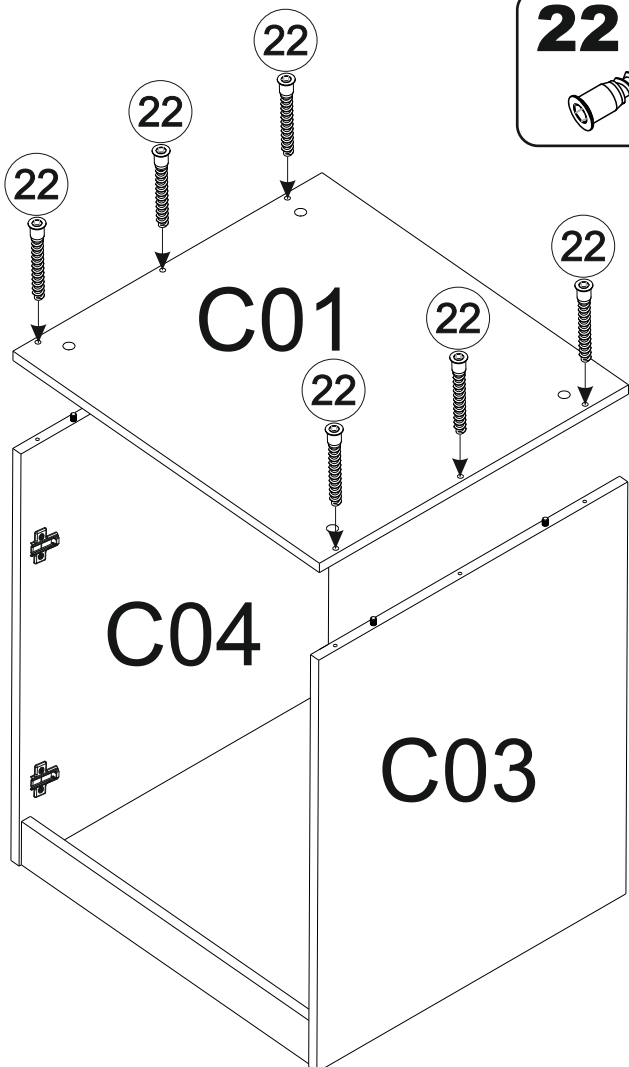
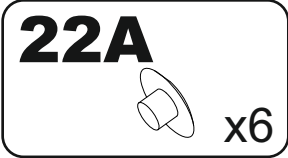
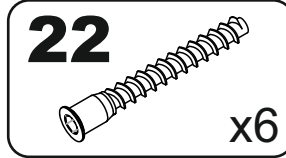

7

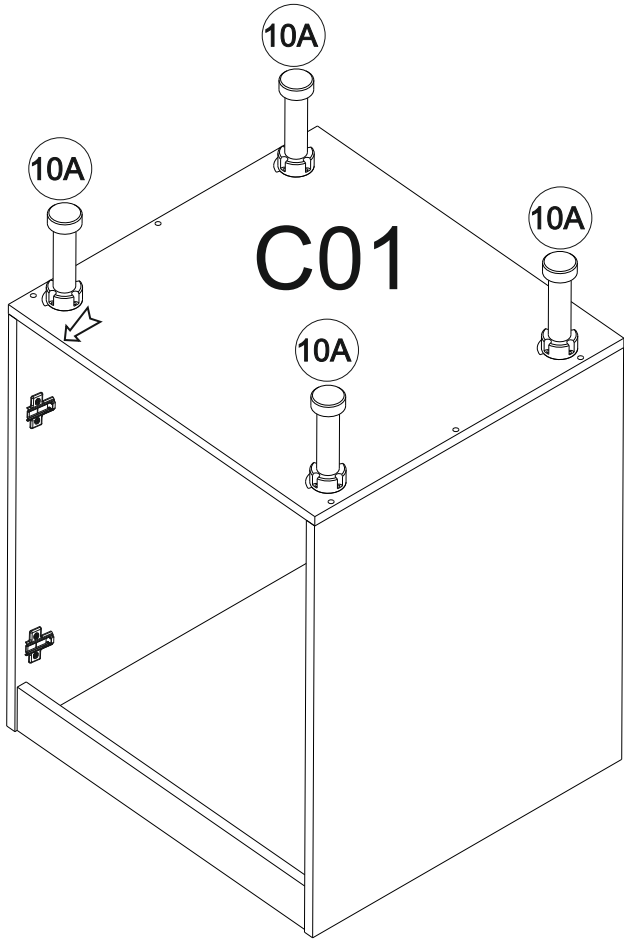

- 10A** x4
- 11** 3.5x13 x16

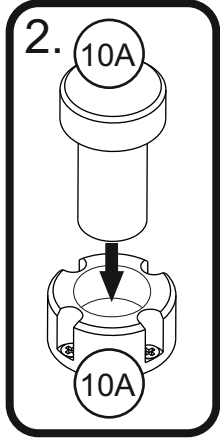
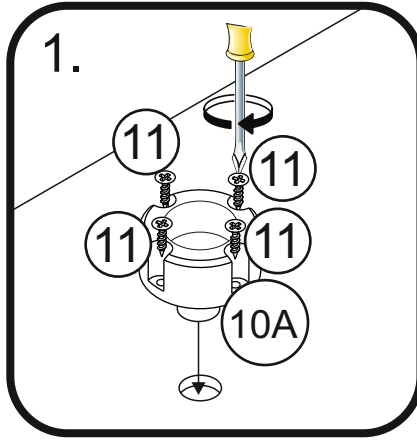
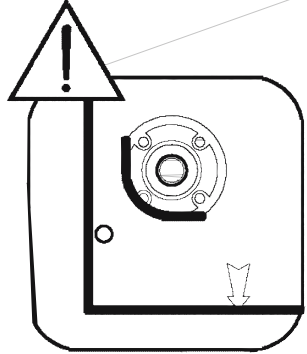

8

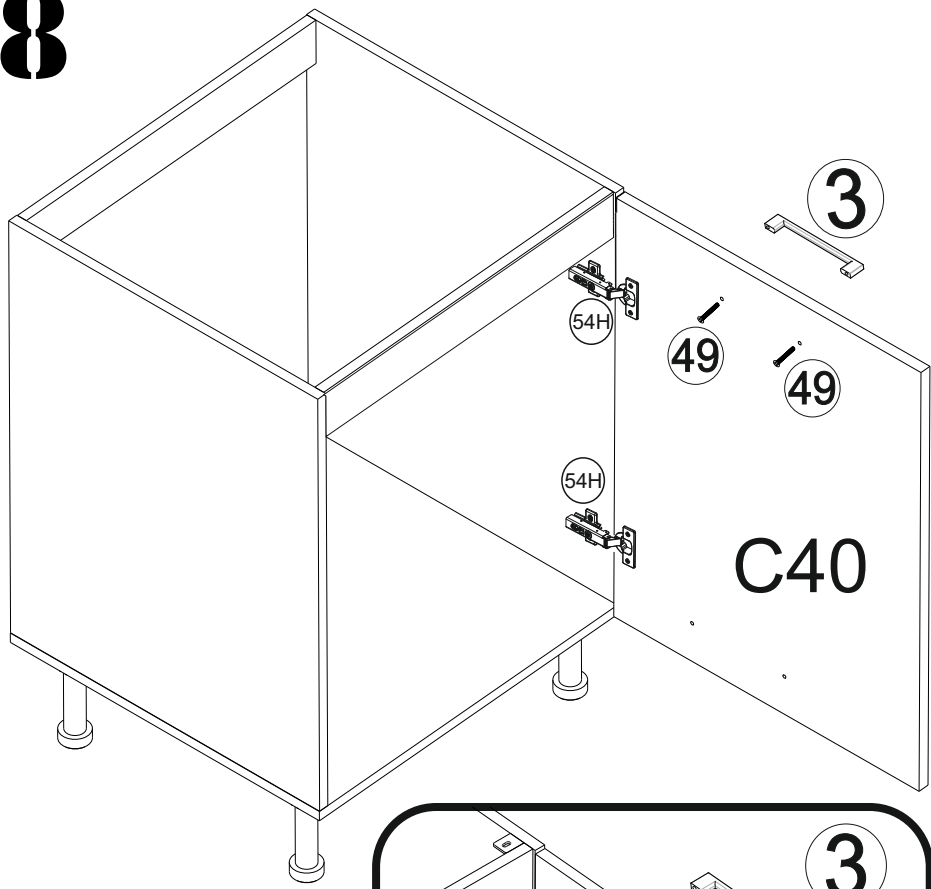

- 3** x1

- 49** M4x22 x2

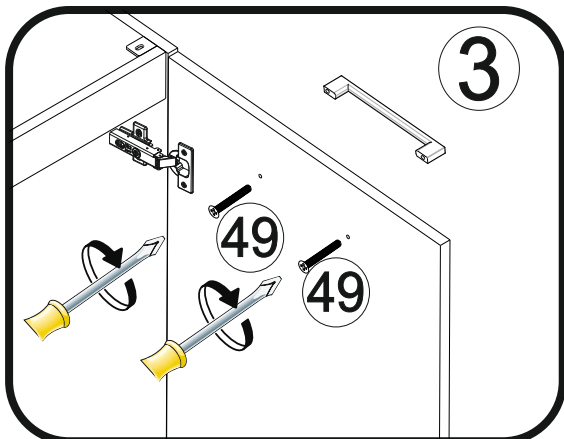
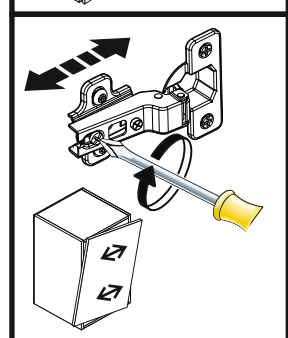
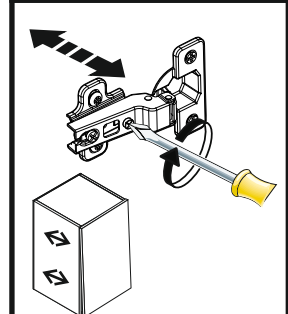
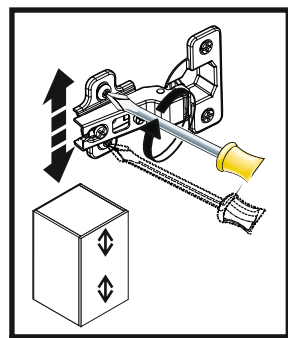
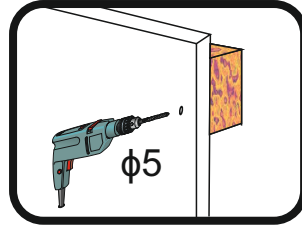
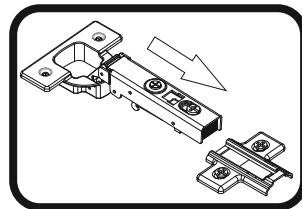

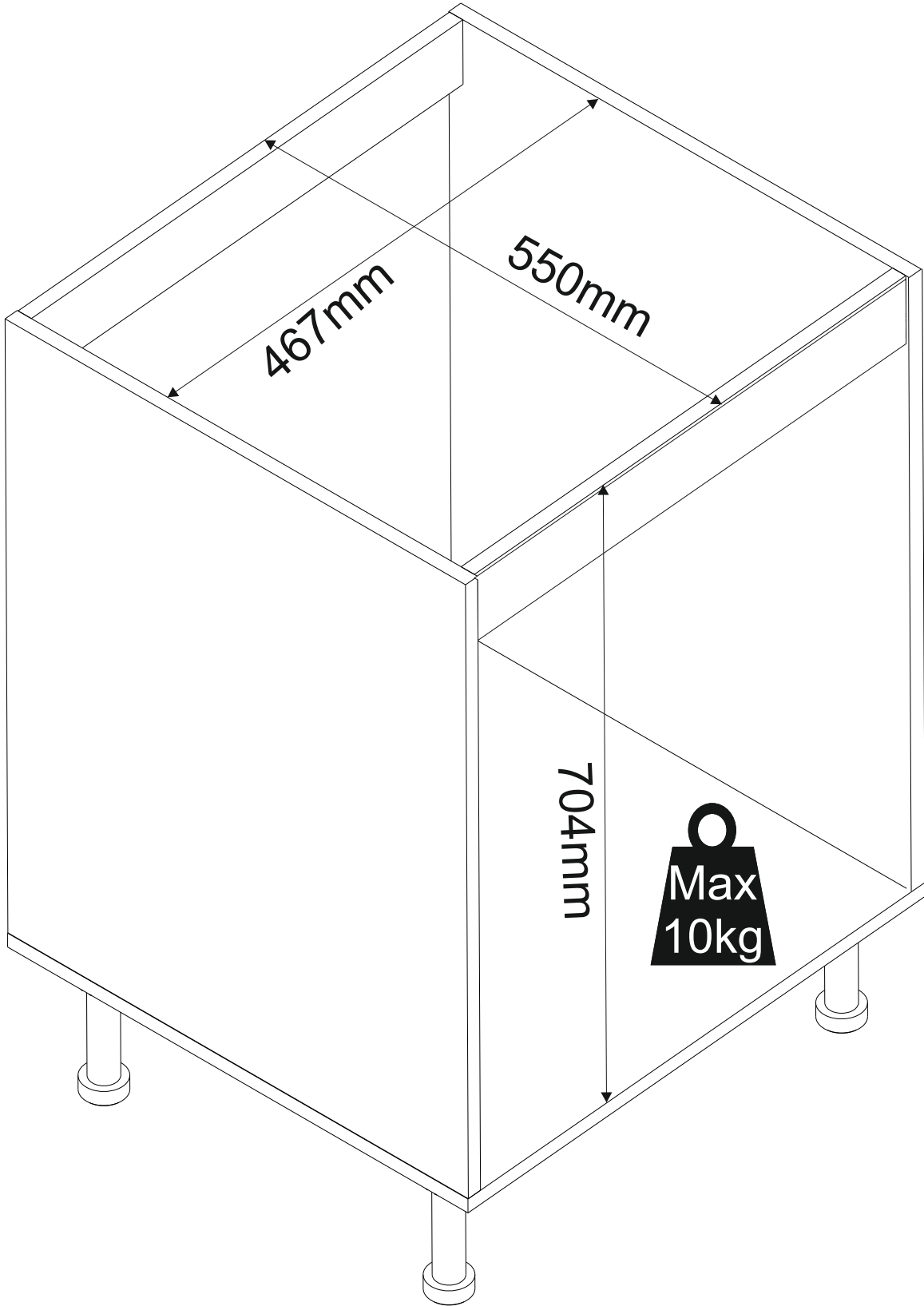
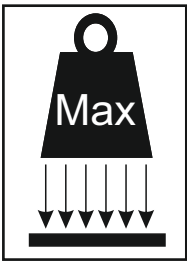

D

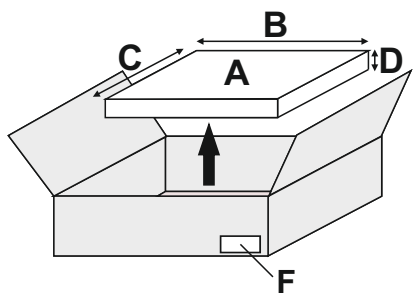
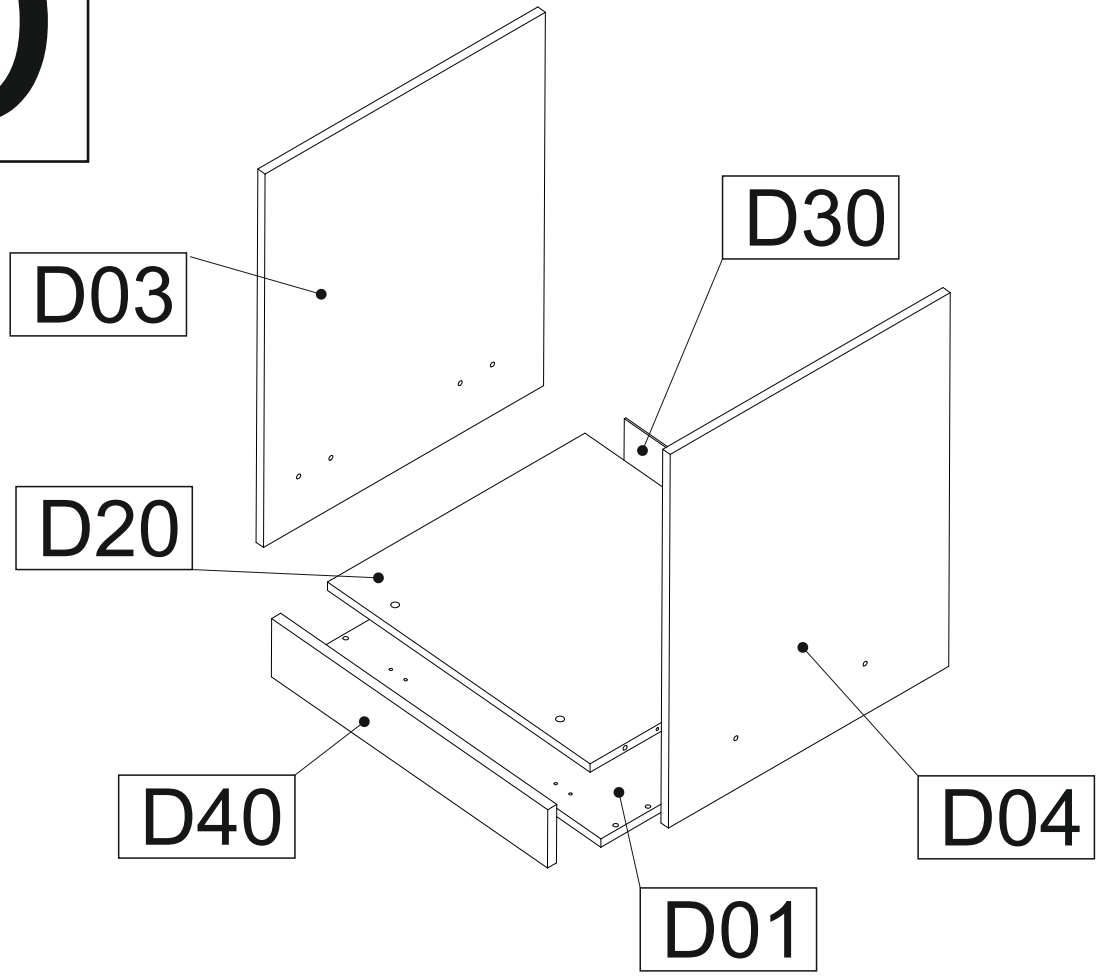

D01	600	555	16	1	5 6
D03	704	555	16	1	5 6
D04	704	555	16	1	5 6
D20	567	510	16	1	5 6
D30	564	103	3	1	5 6
D40	596	110	18	1	5 6

1

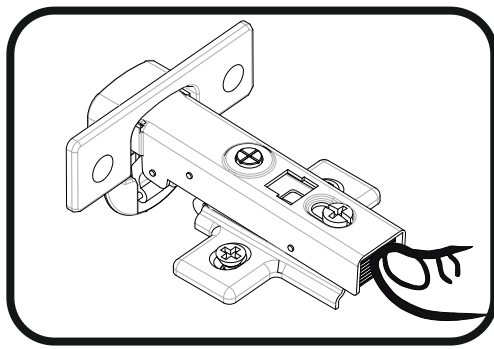
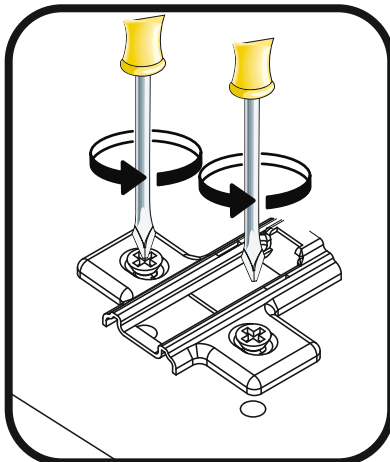
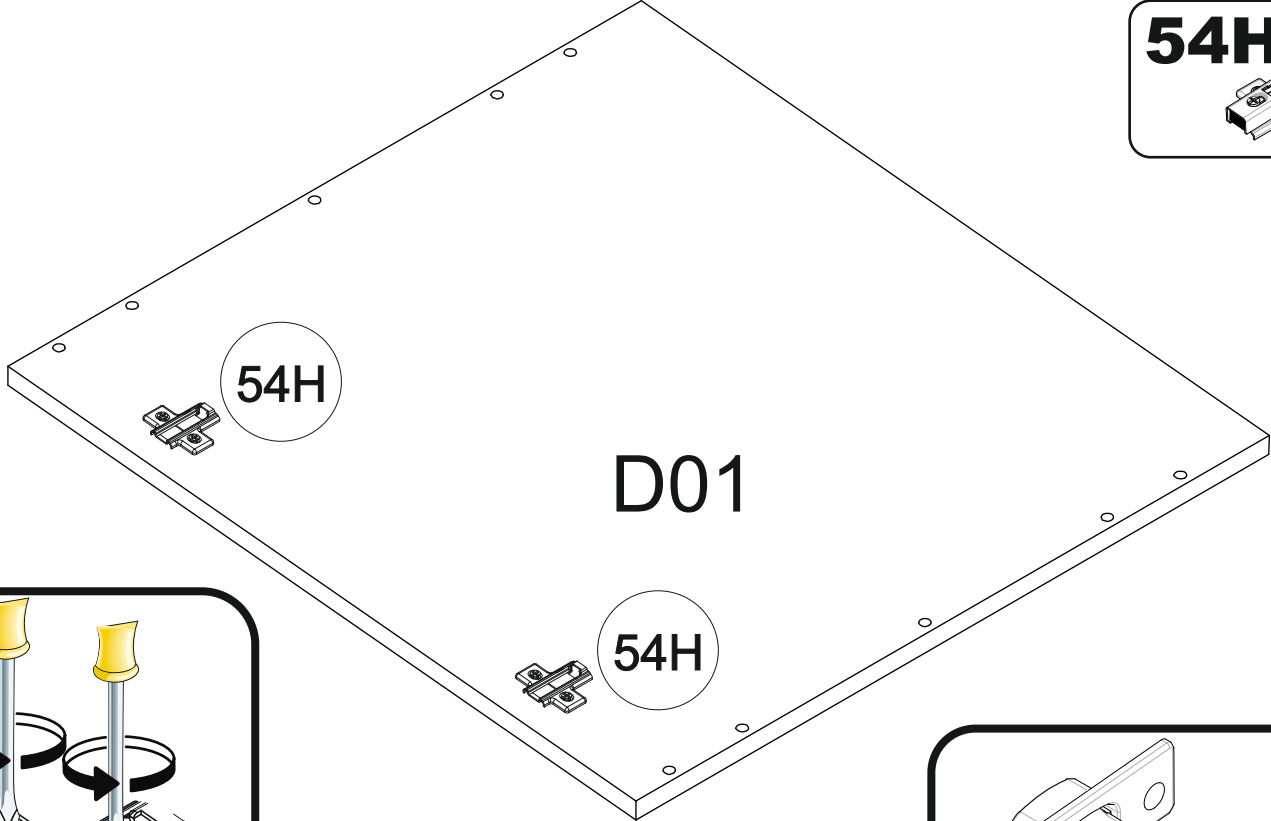
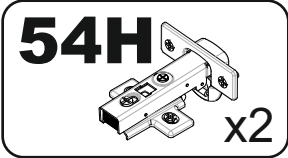

2

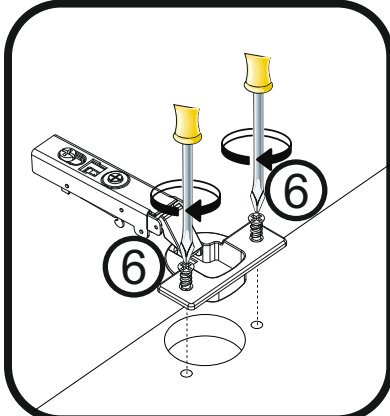
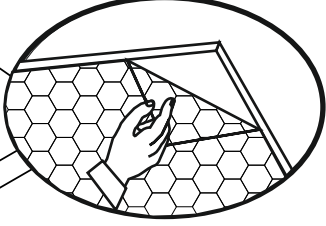
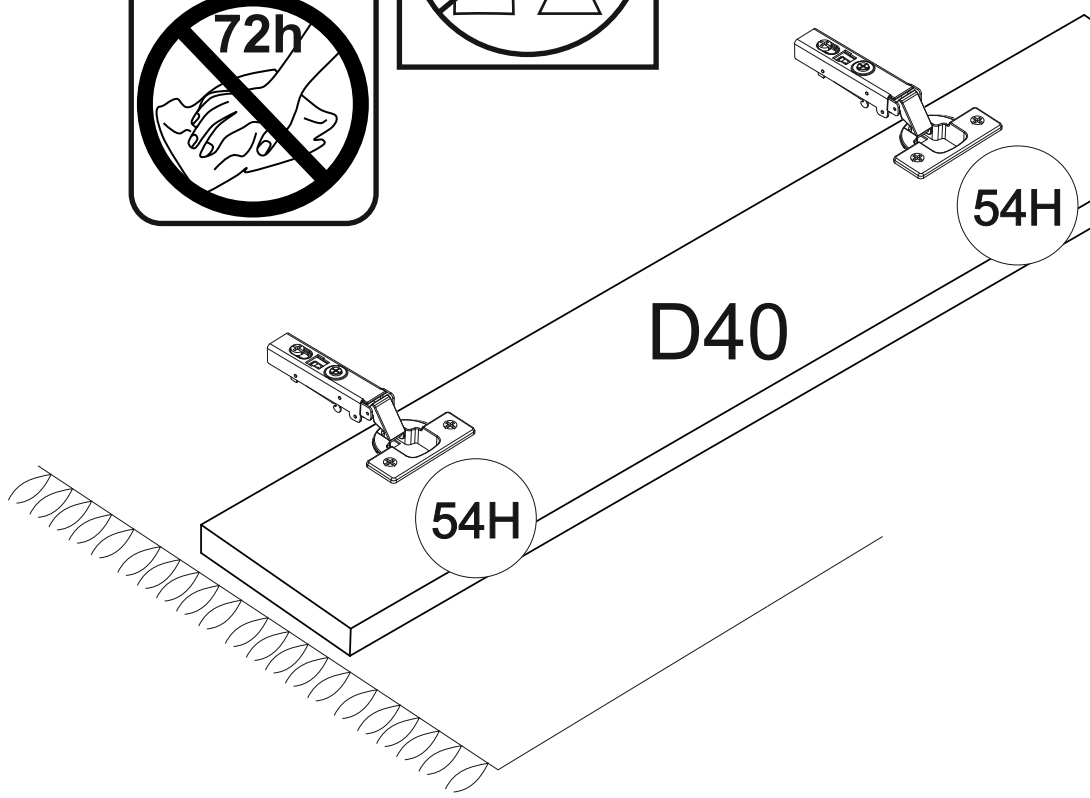
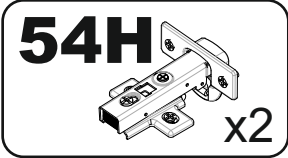
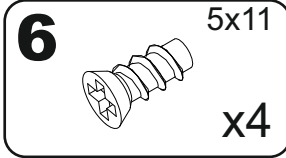
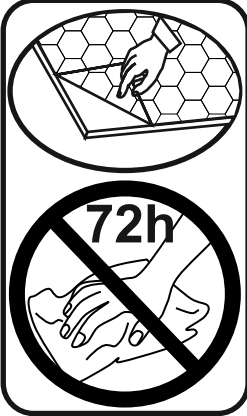

3

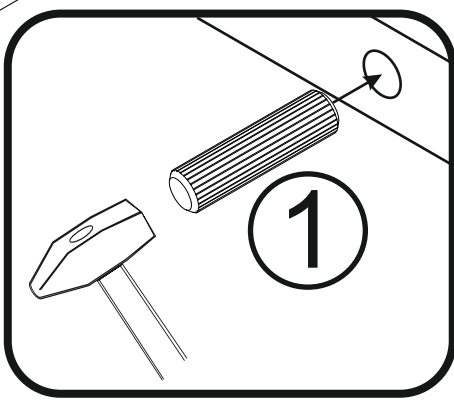
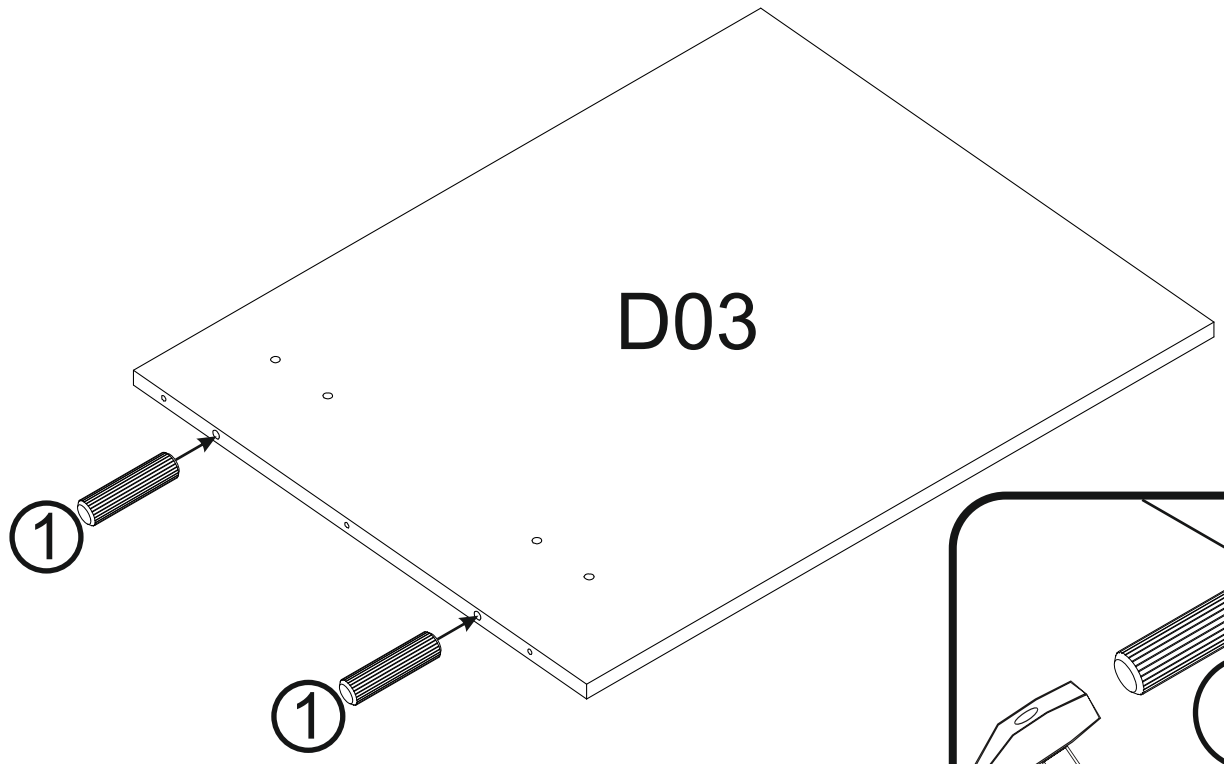
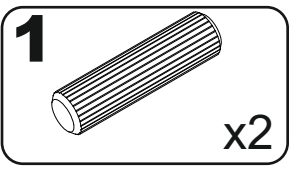

4

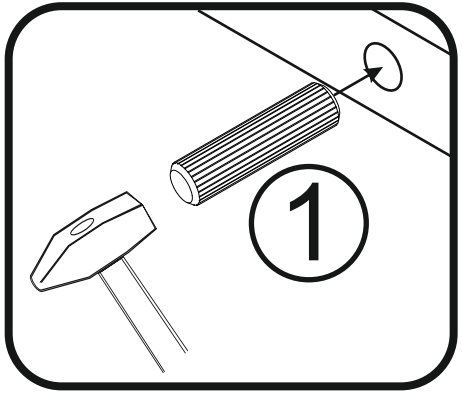
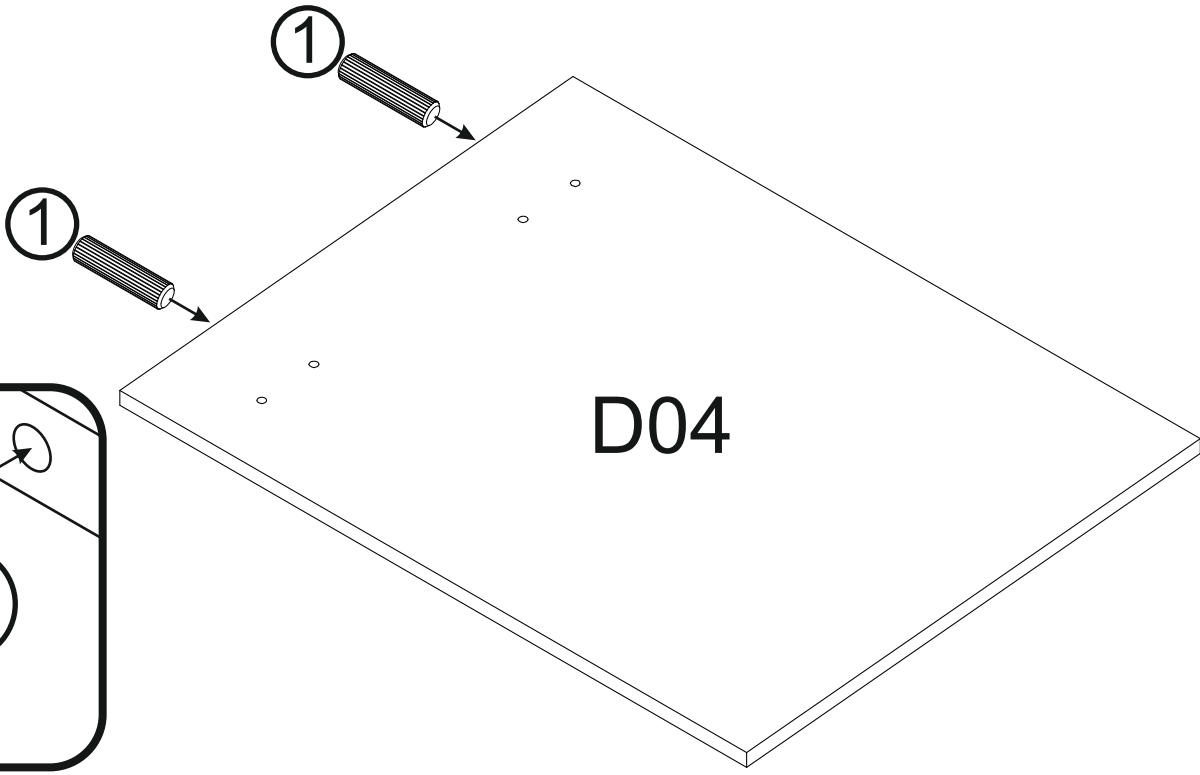
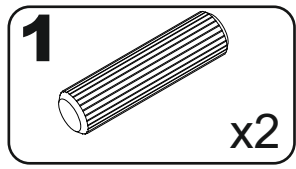

5

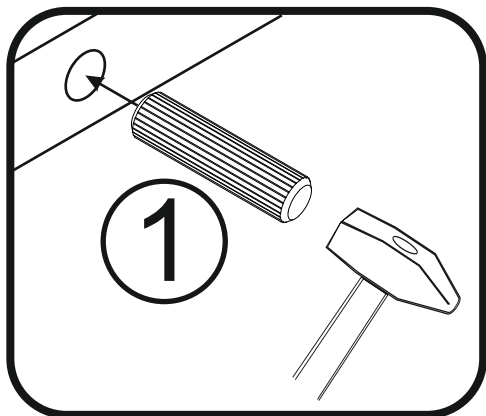
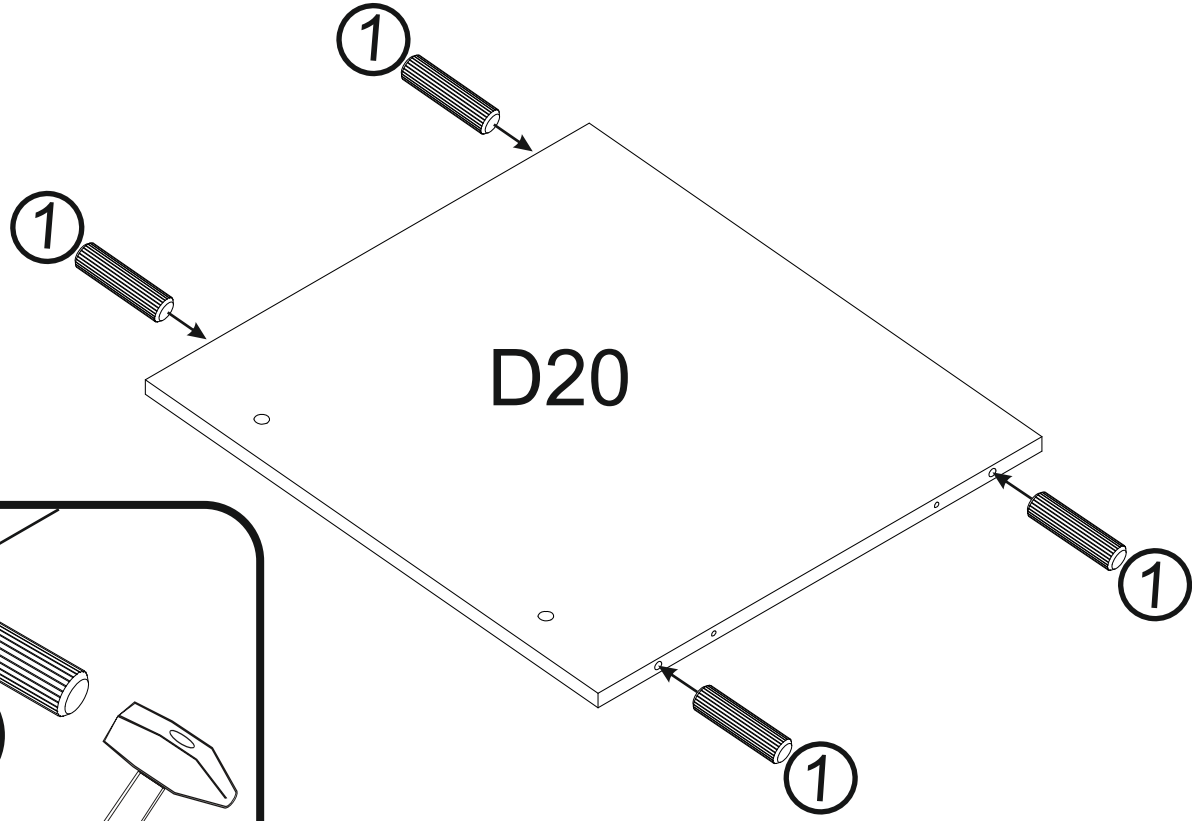
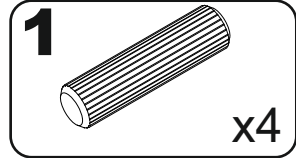

6

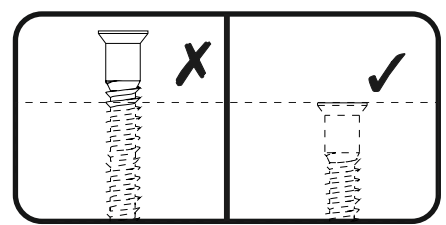
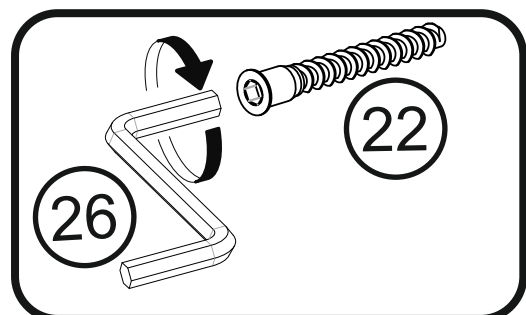
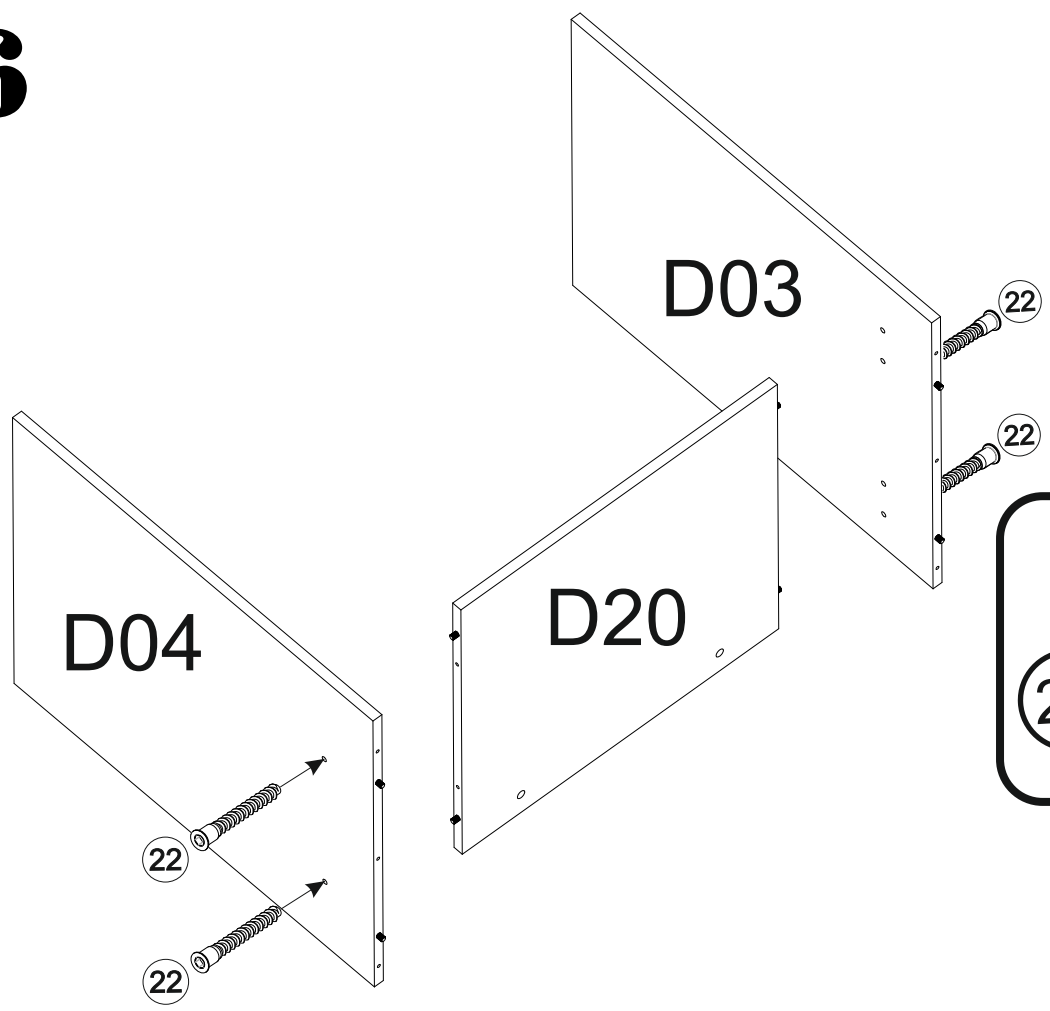
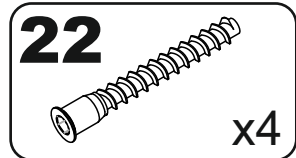

7

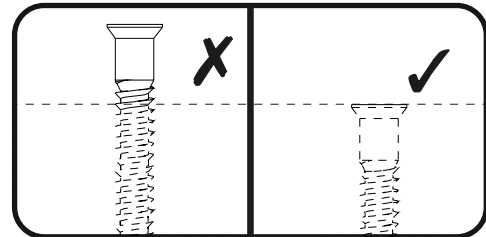
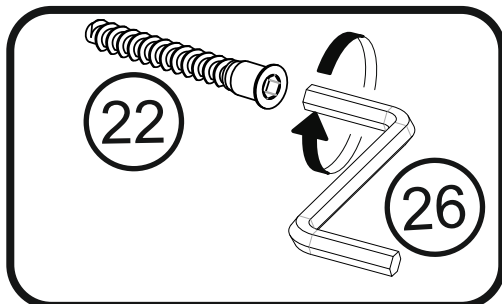
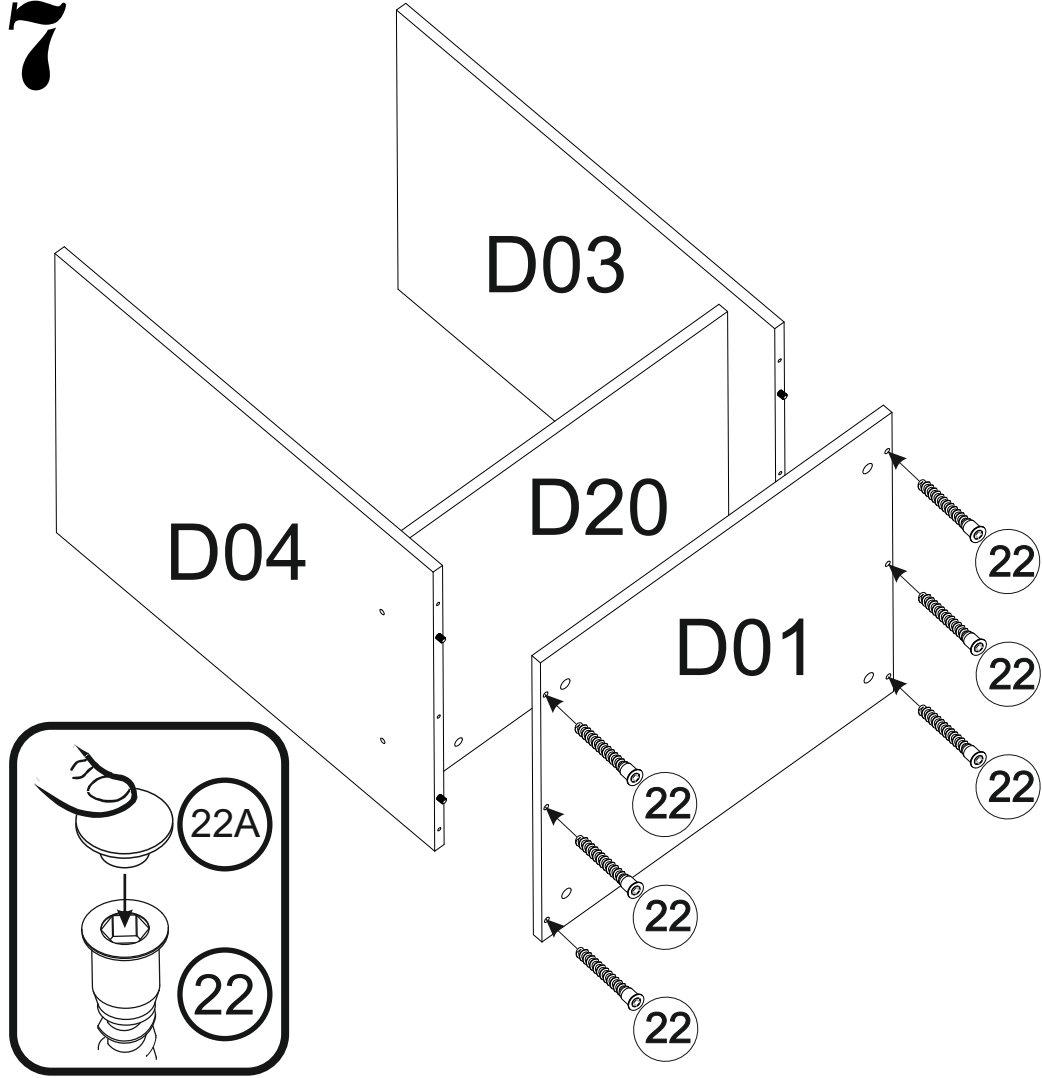
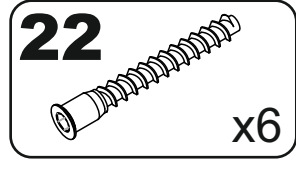

8

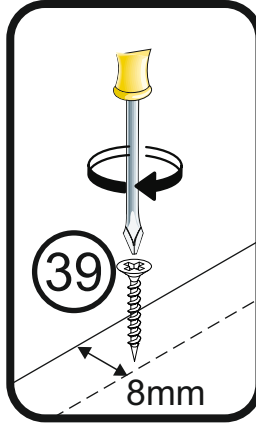
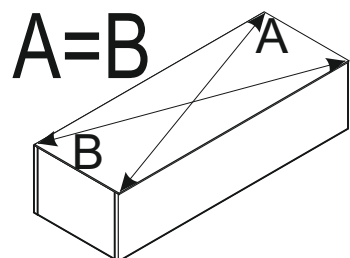
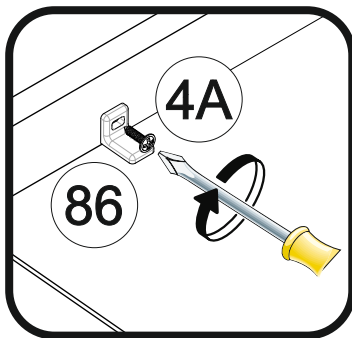
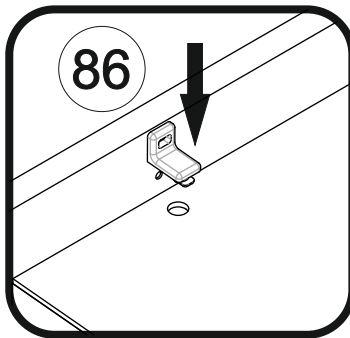
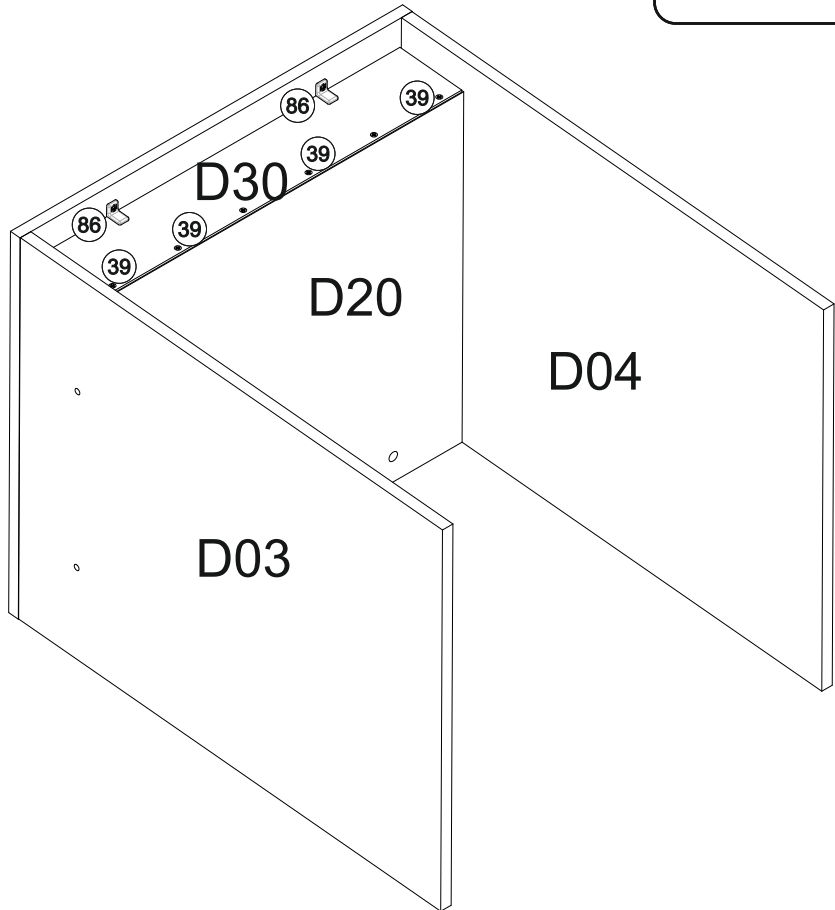
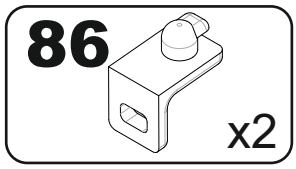
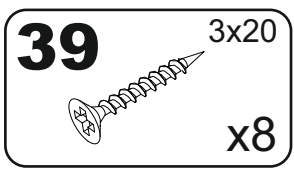
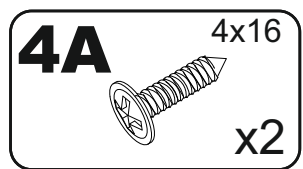

9

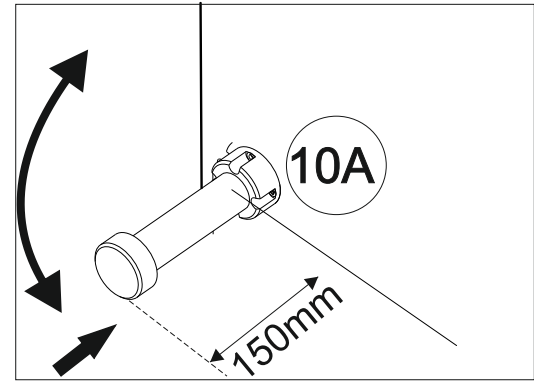
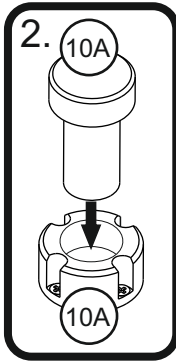
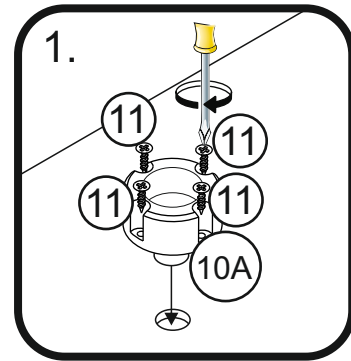
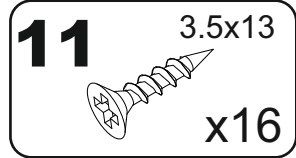
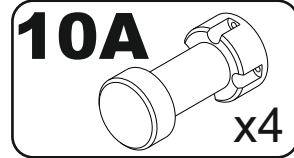
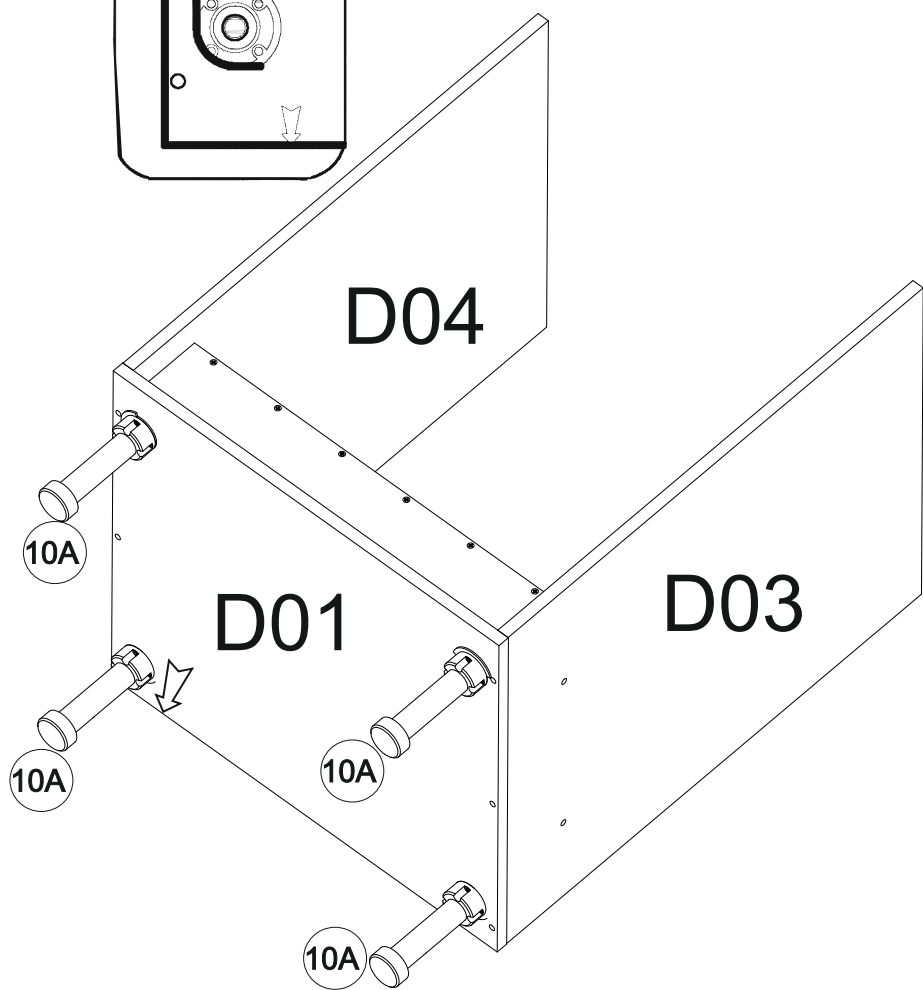
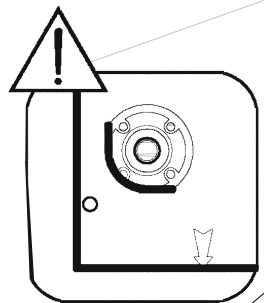

10

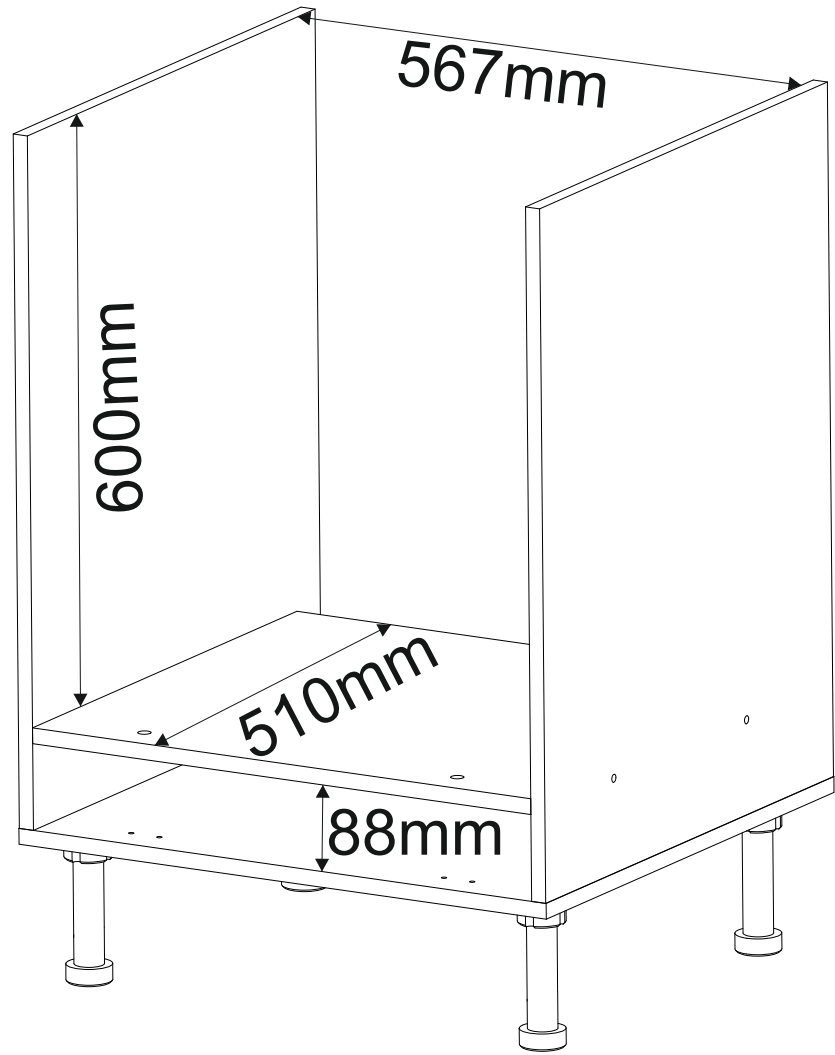

G

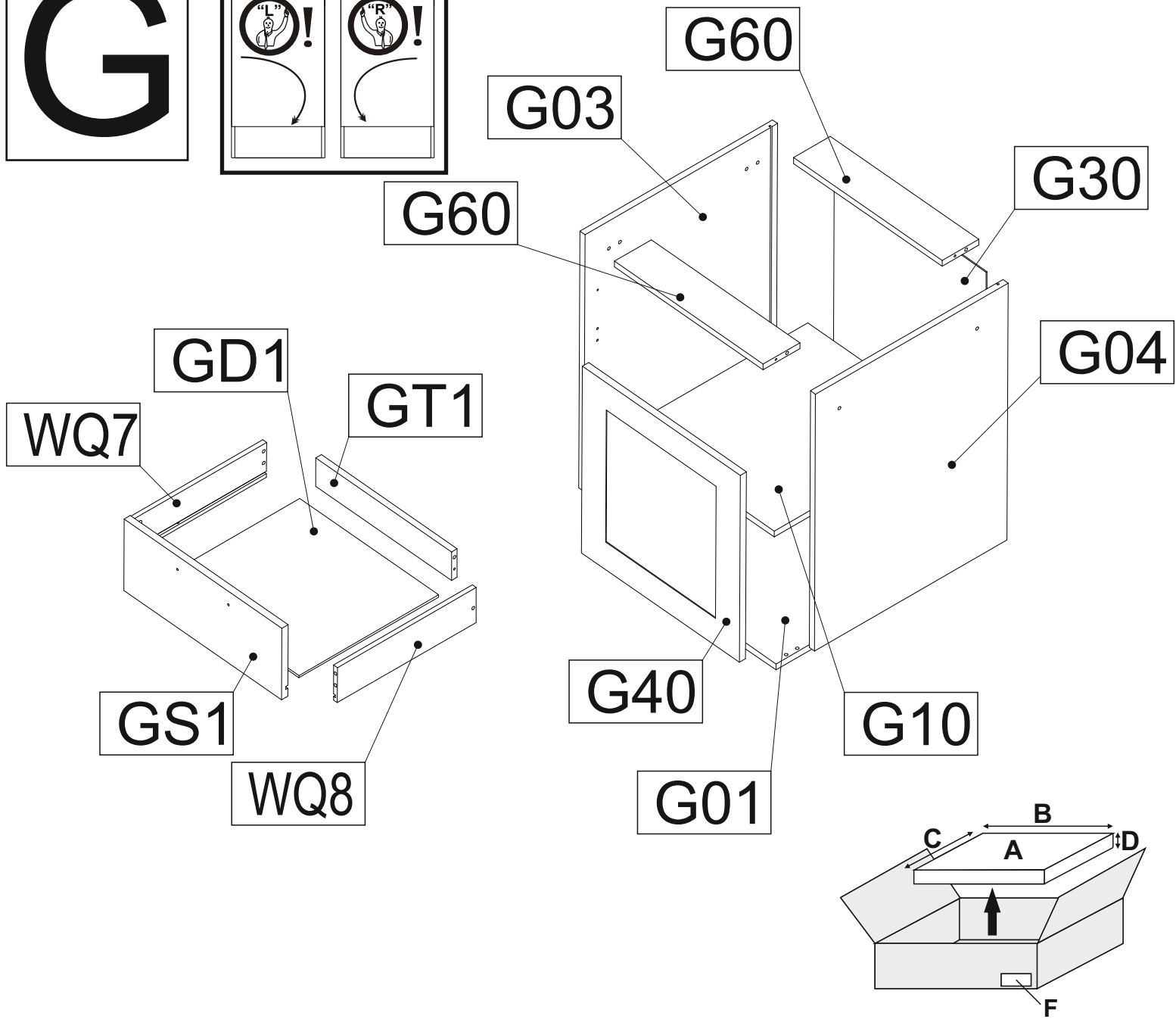
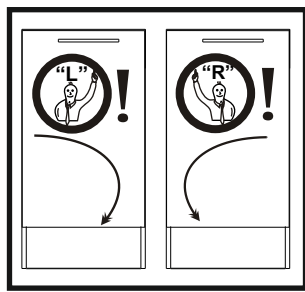

A	B_(mm)	C_(mm)	D_(mm)	E	F
G01	500	555	16	1	3 6
G03	704	555	16	1	3 6
G04	704	555	16	1	3 6
G10	467	525	16	1	3 6
G30	639	477	3	1	3 6
G40	496	512	18	1	3 6
G60	467	106	16	2	3 6
GD1	437	403	6	1	3 6
GS1	496	196	18	1	3 6
GT1	427	78	16	1	3 6
WQ7	400	96	12	1	3 6
WQ8	400	96	12	1	3 6

1

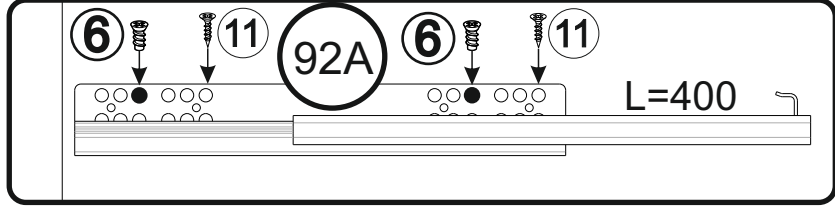
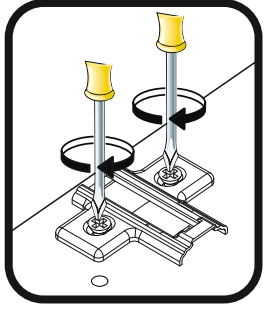
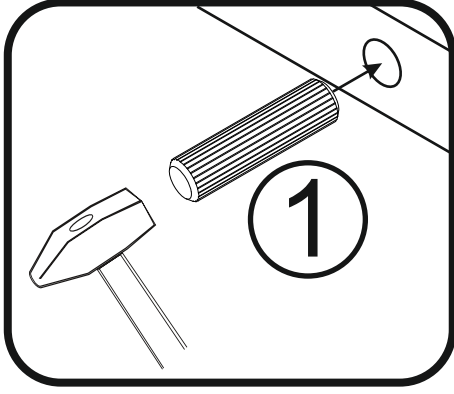
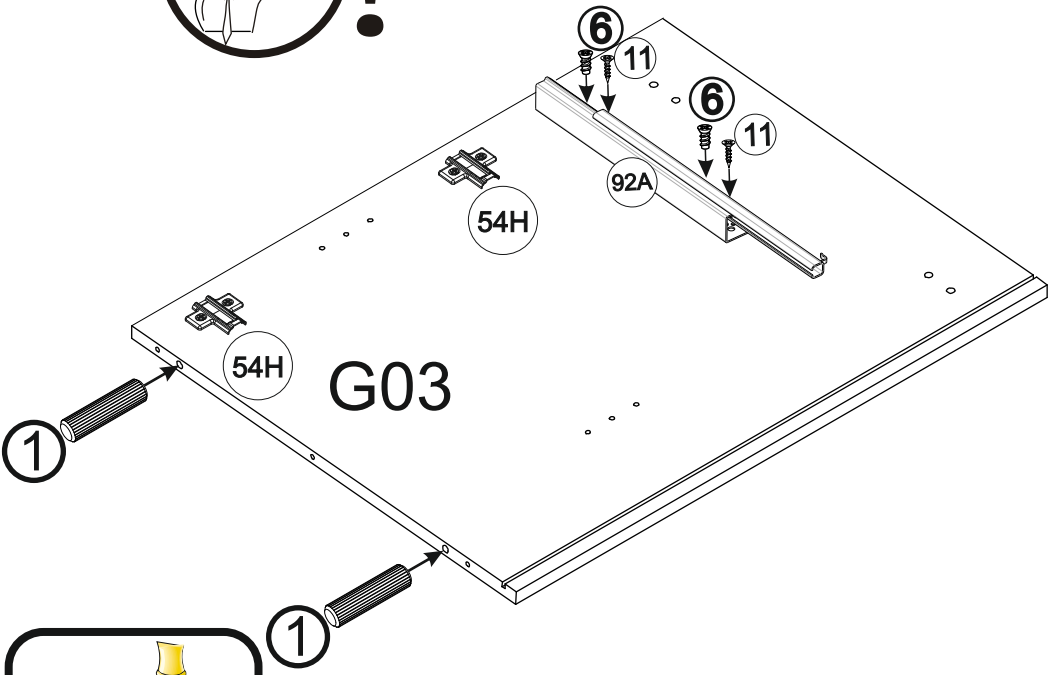
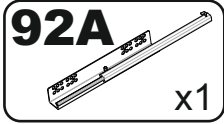
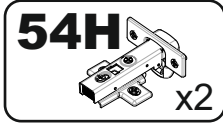
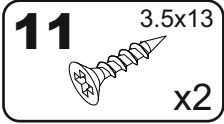
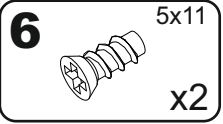
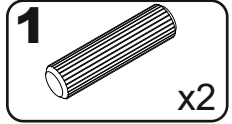
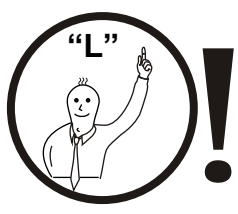

2

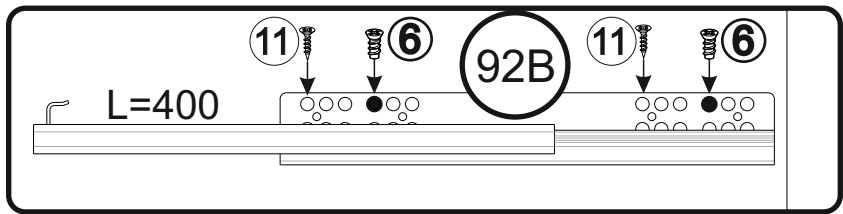
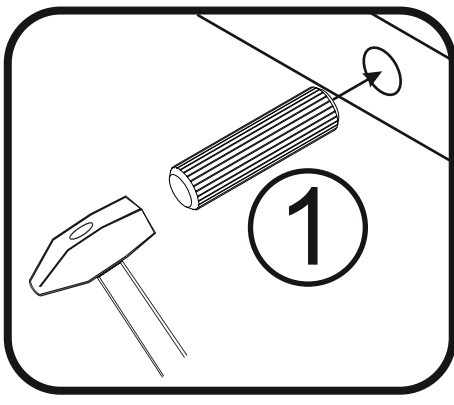
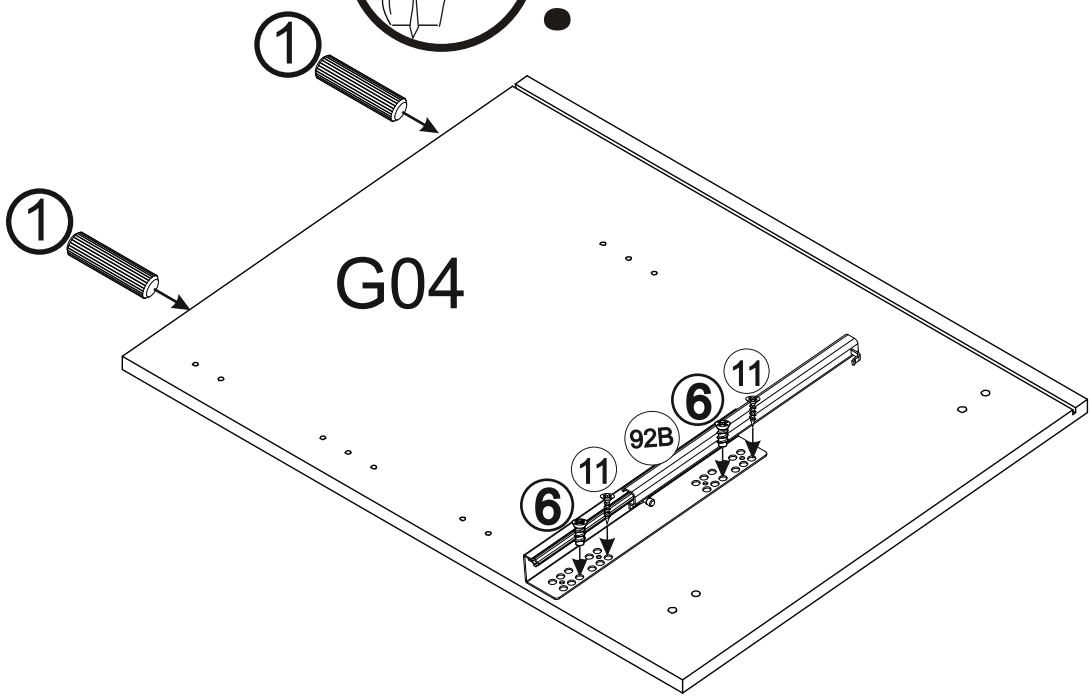
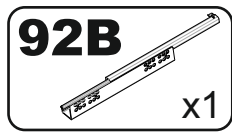
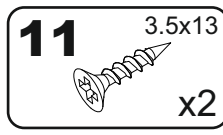
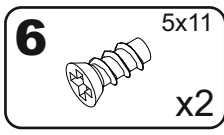
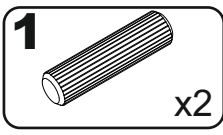
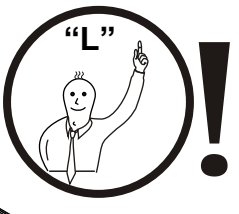

3

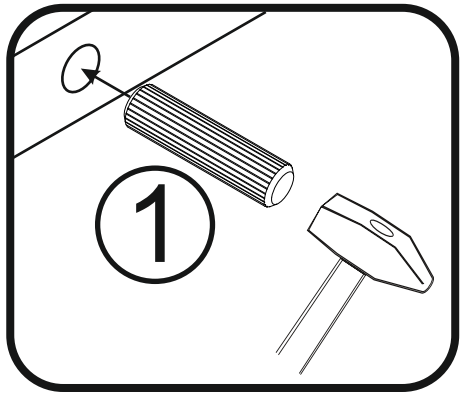
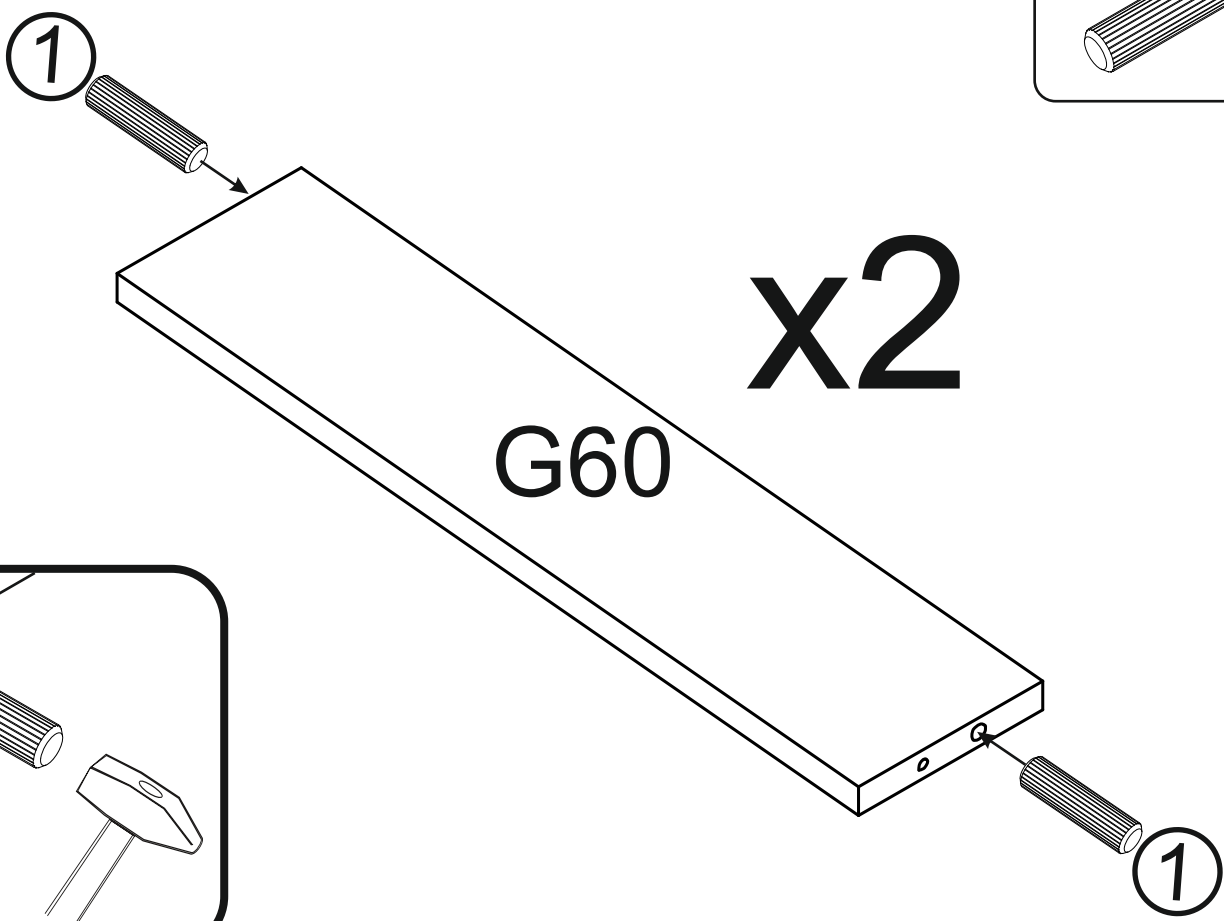
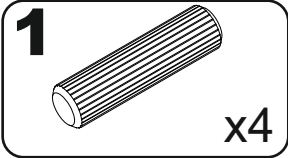

4

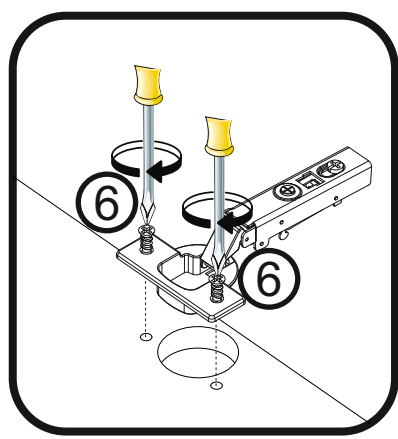
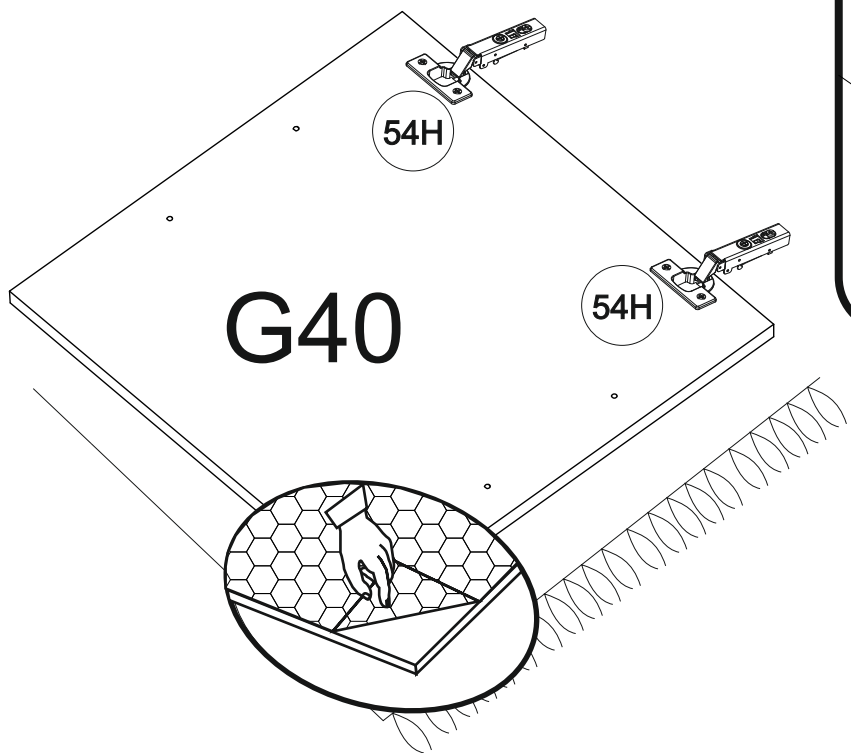
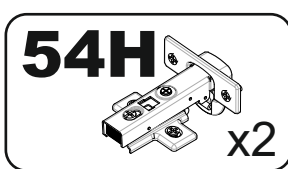
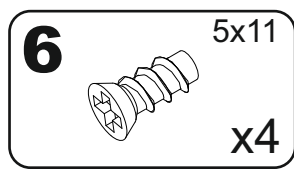

5

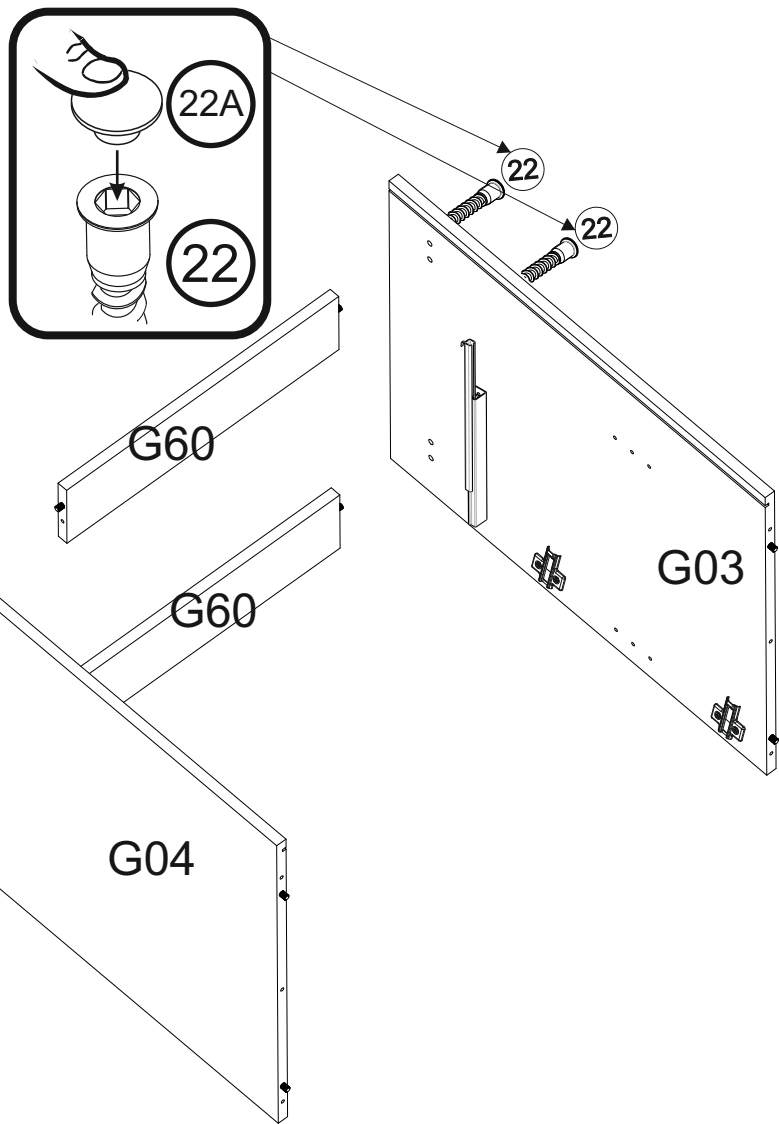

22 x4

22A x2

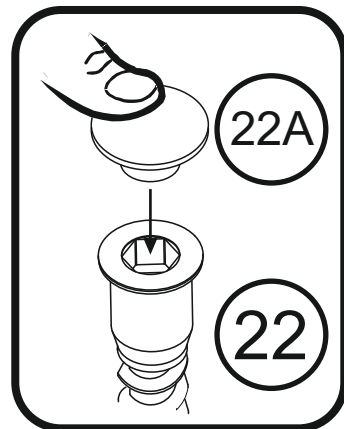
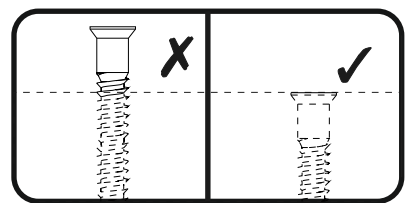
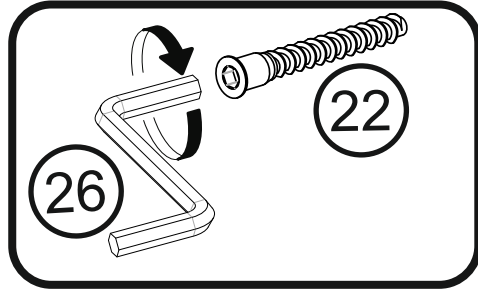

6

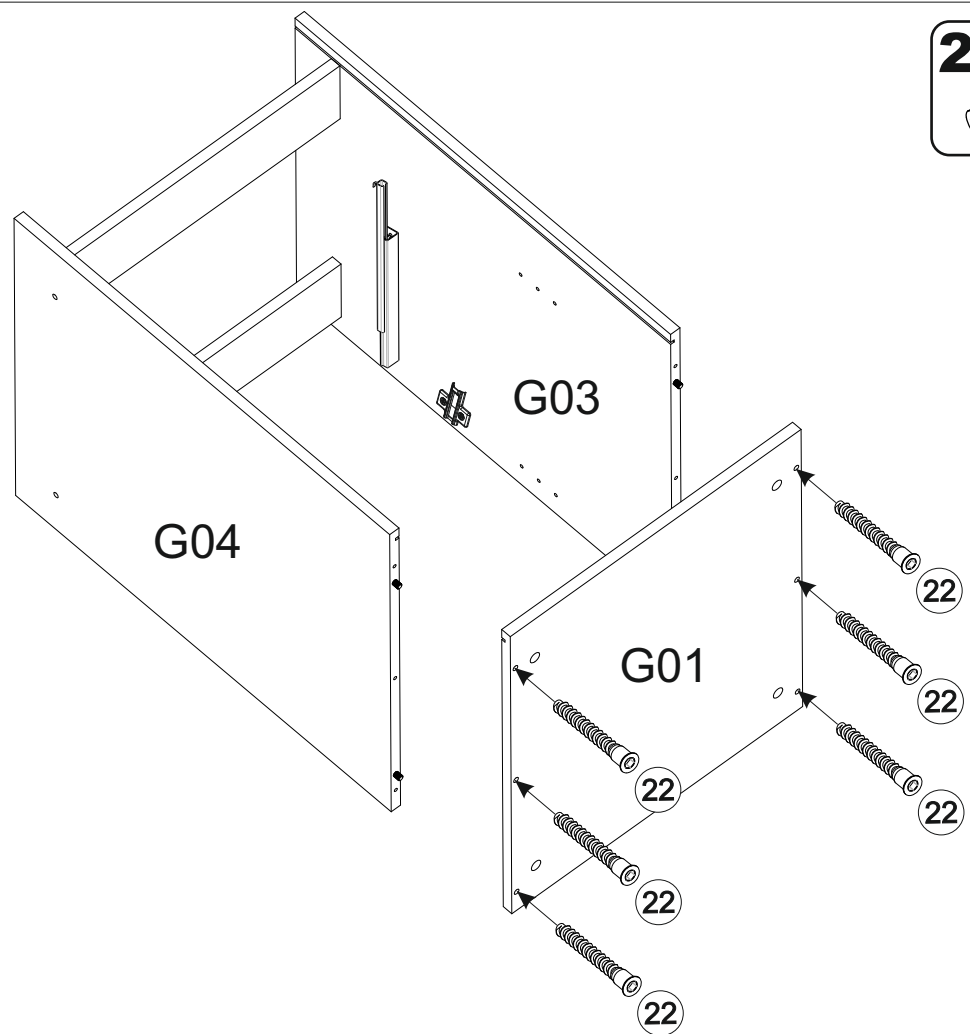

22 x6

22A x6

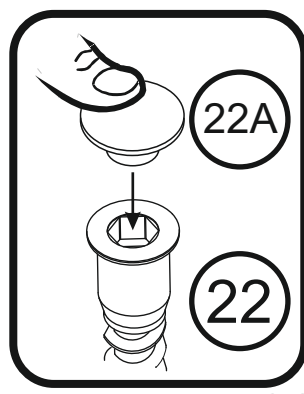
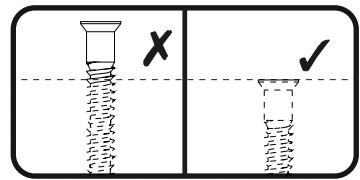
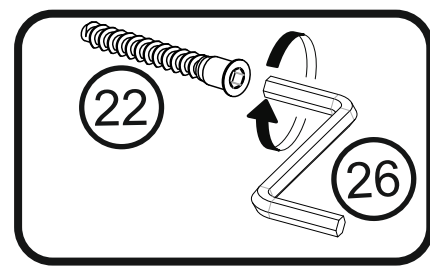

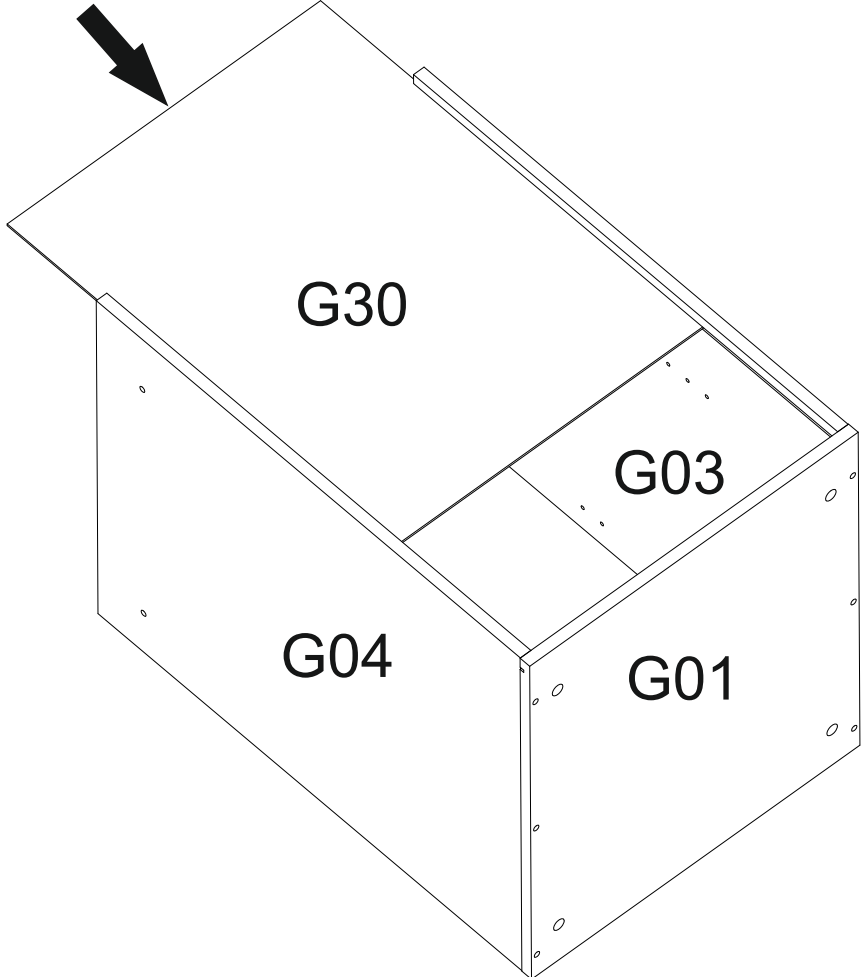

8

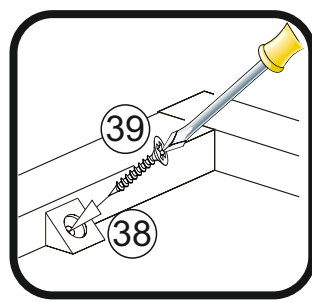
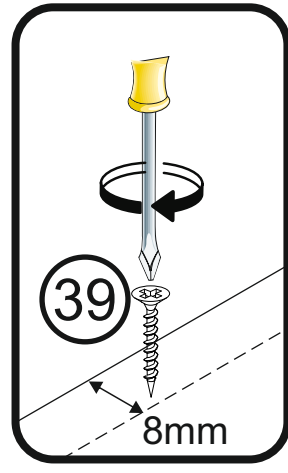
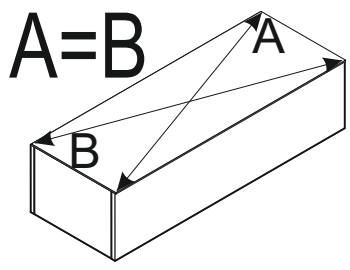
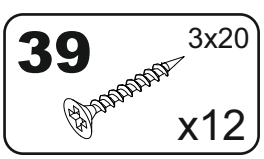
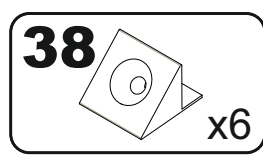
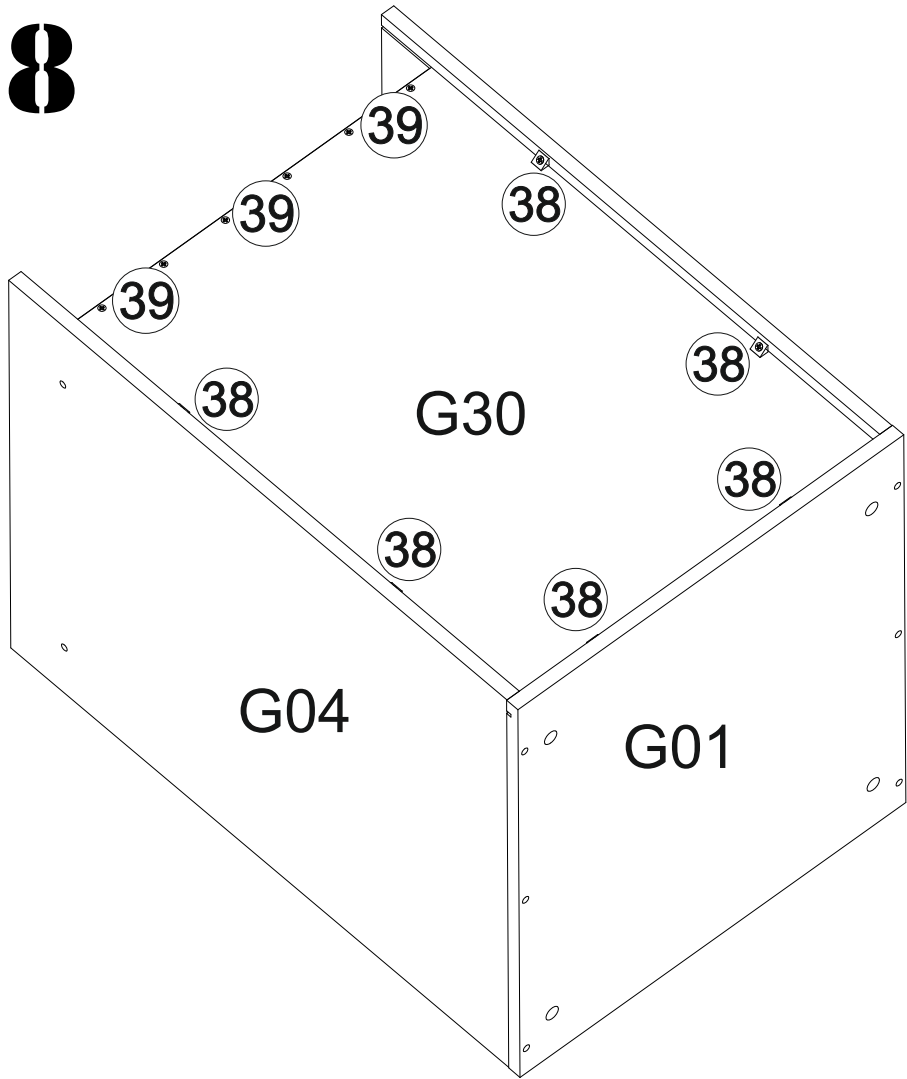

9

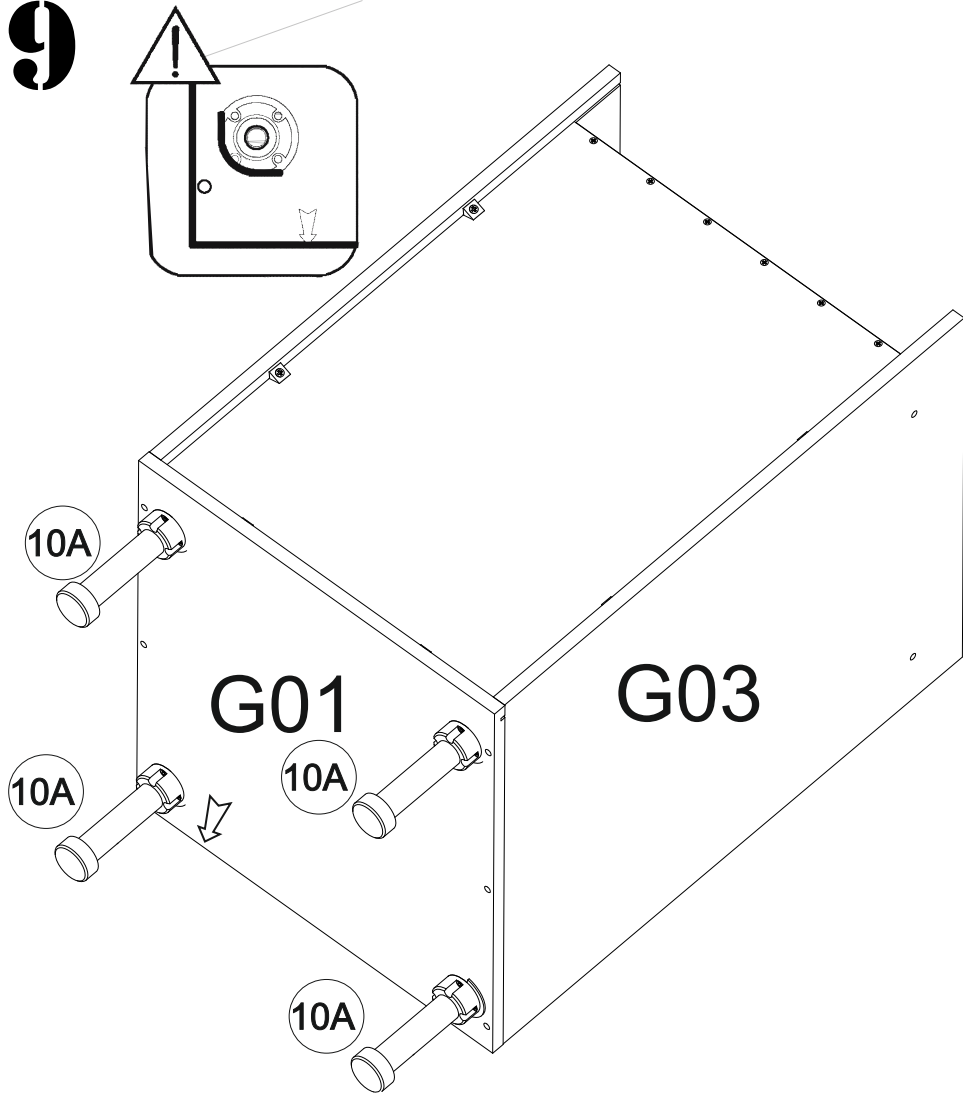

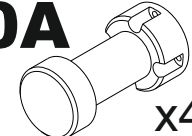
10A  x4

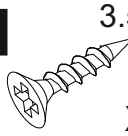
11  3.5x13 x16

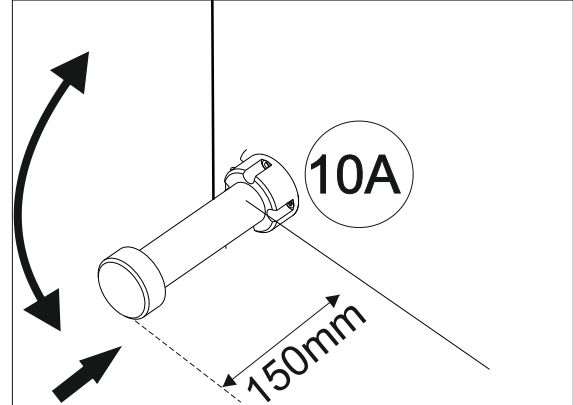
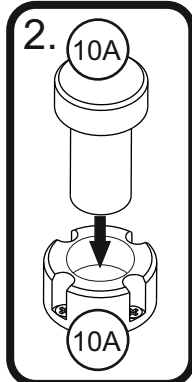
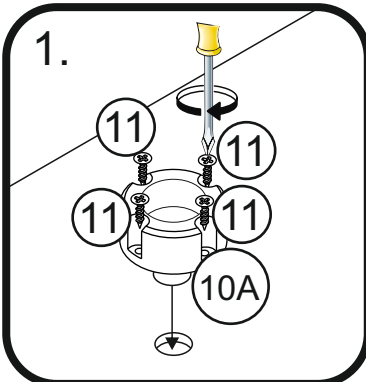

10

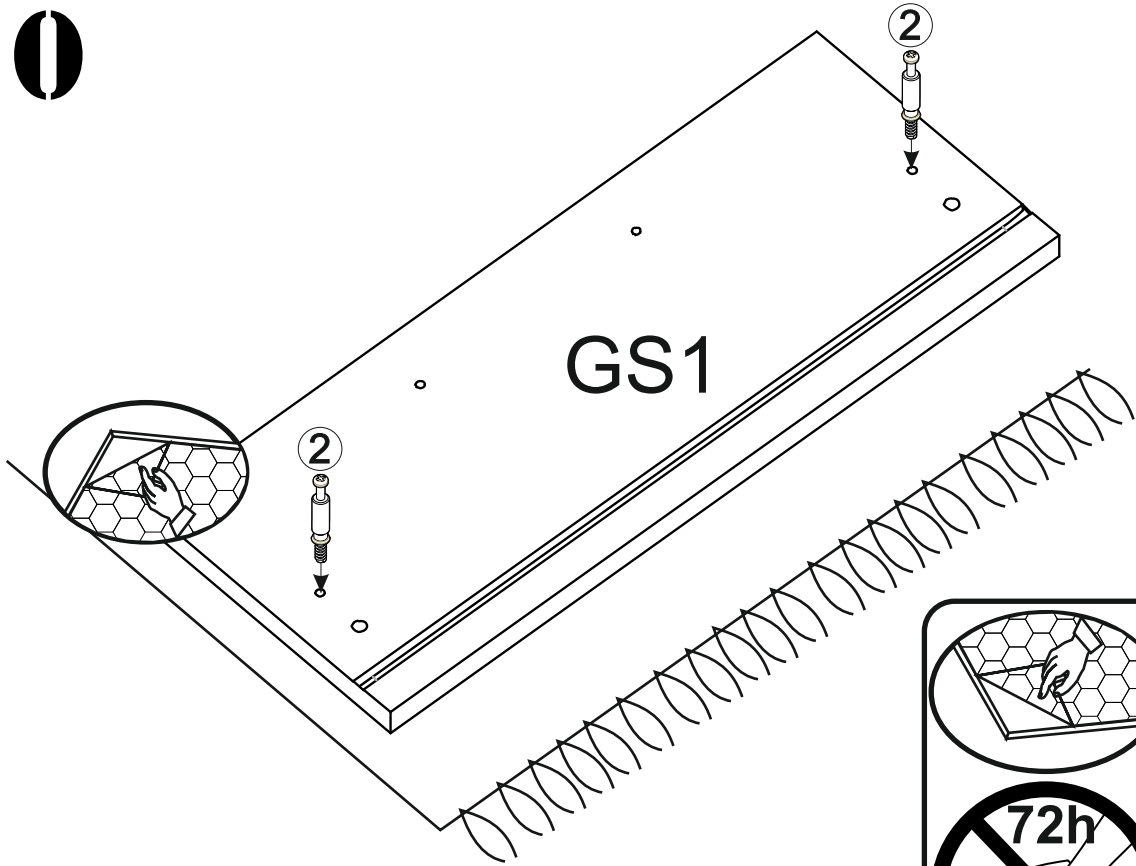

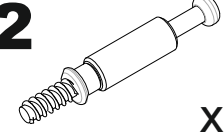
2  x2

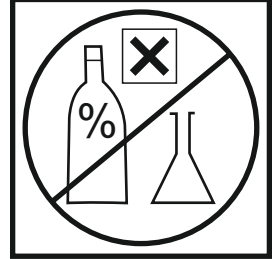
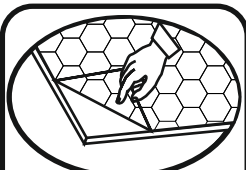
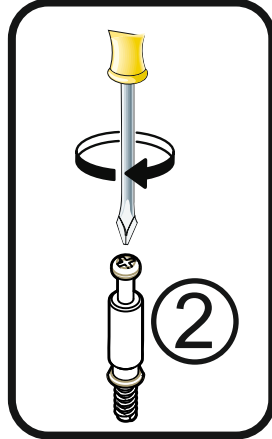

11

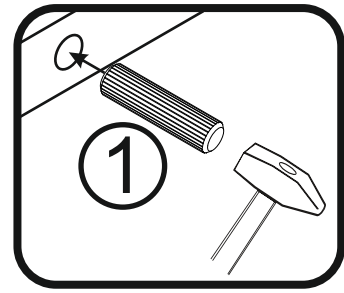
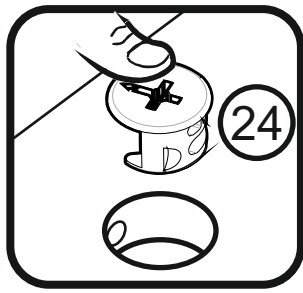
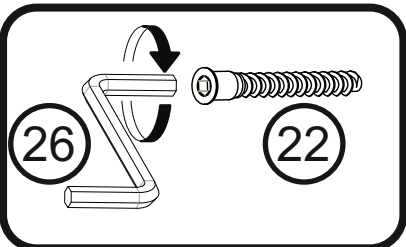
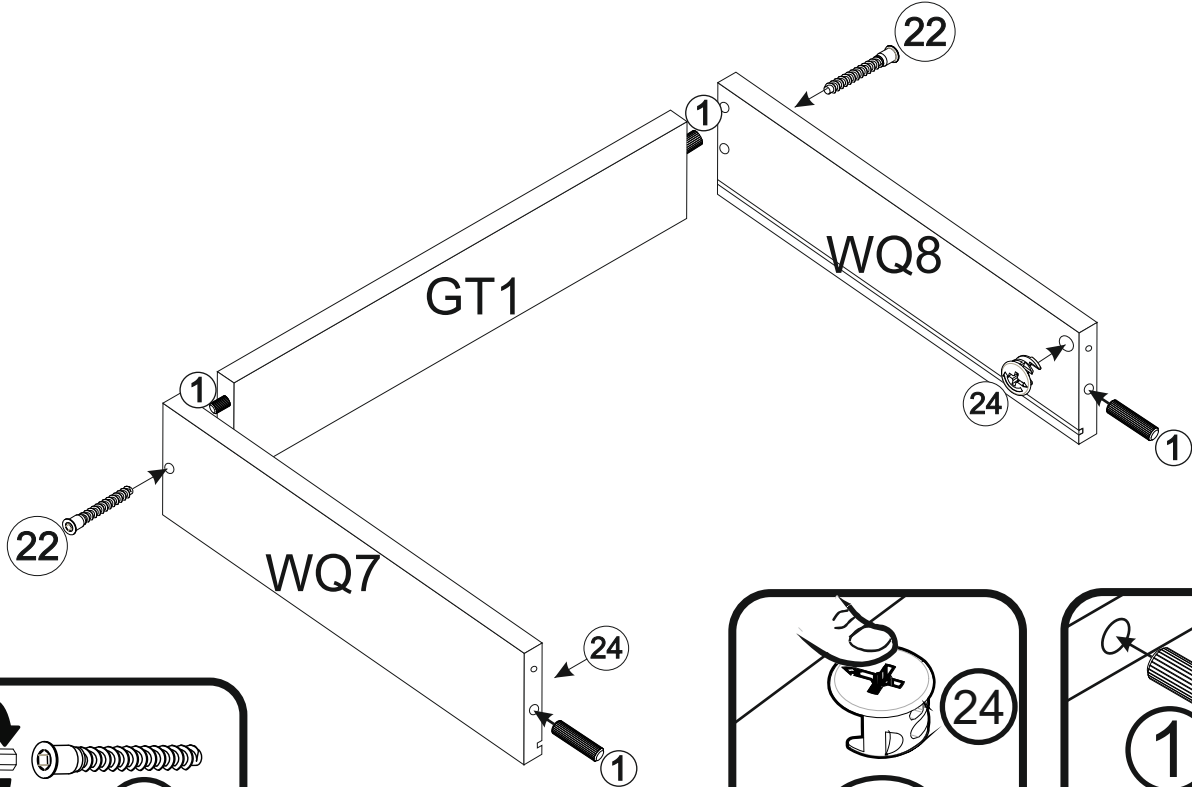
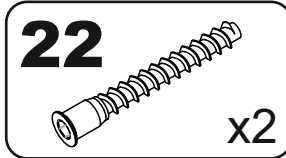
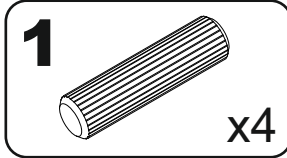

12

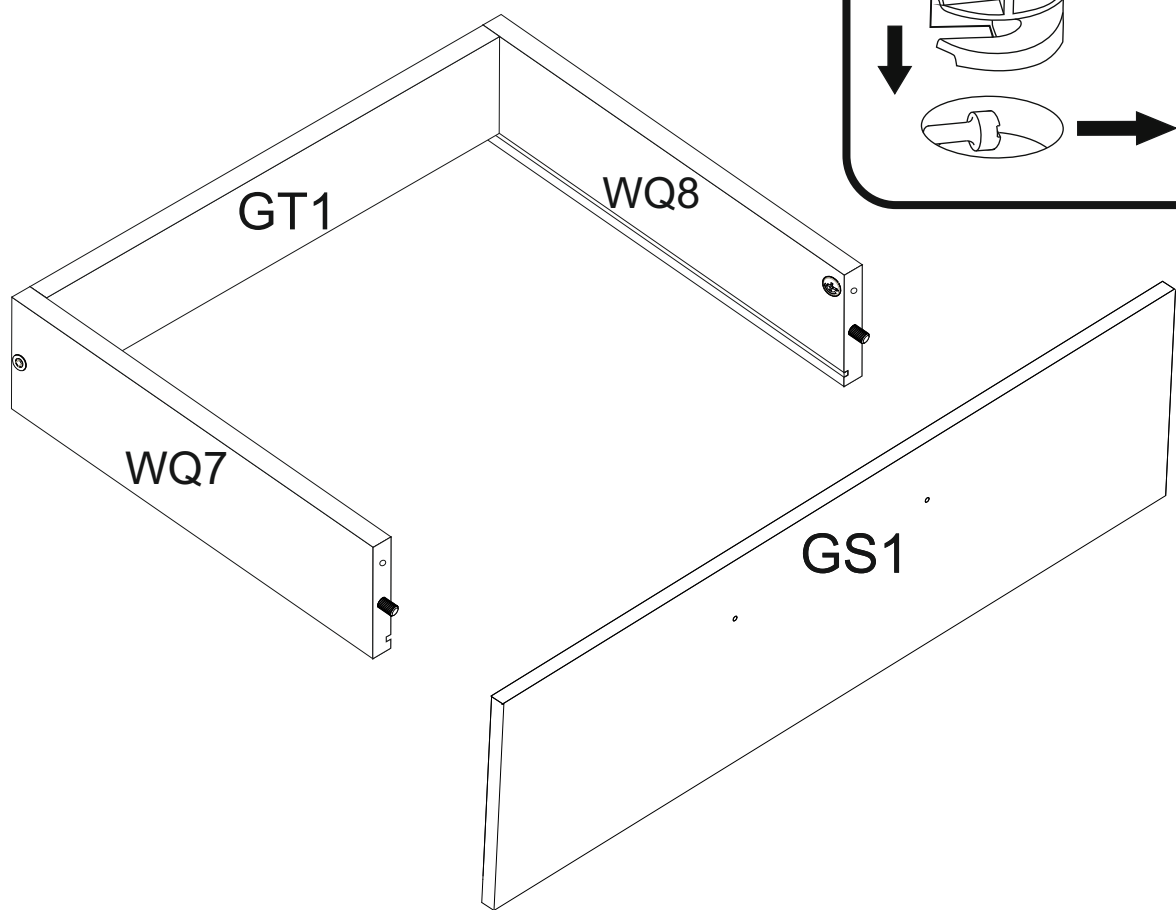
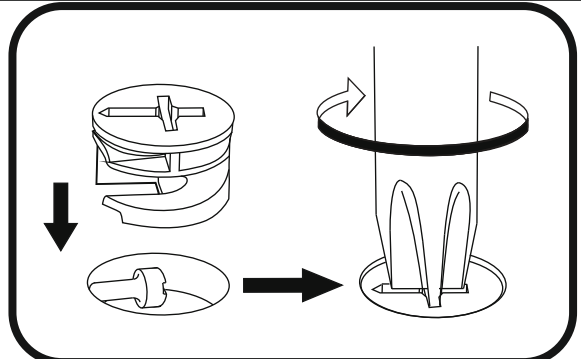

13

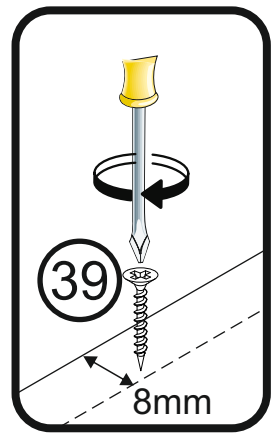
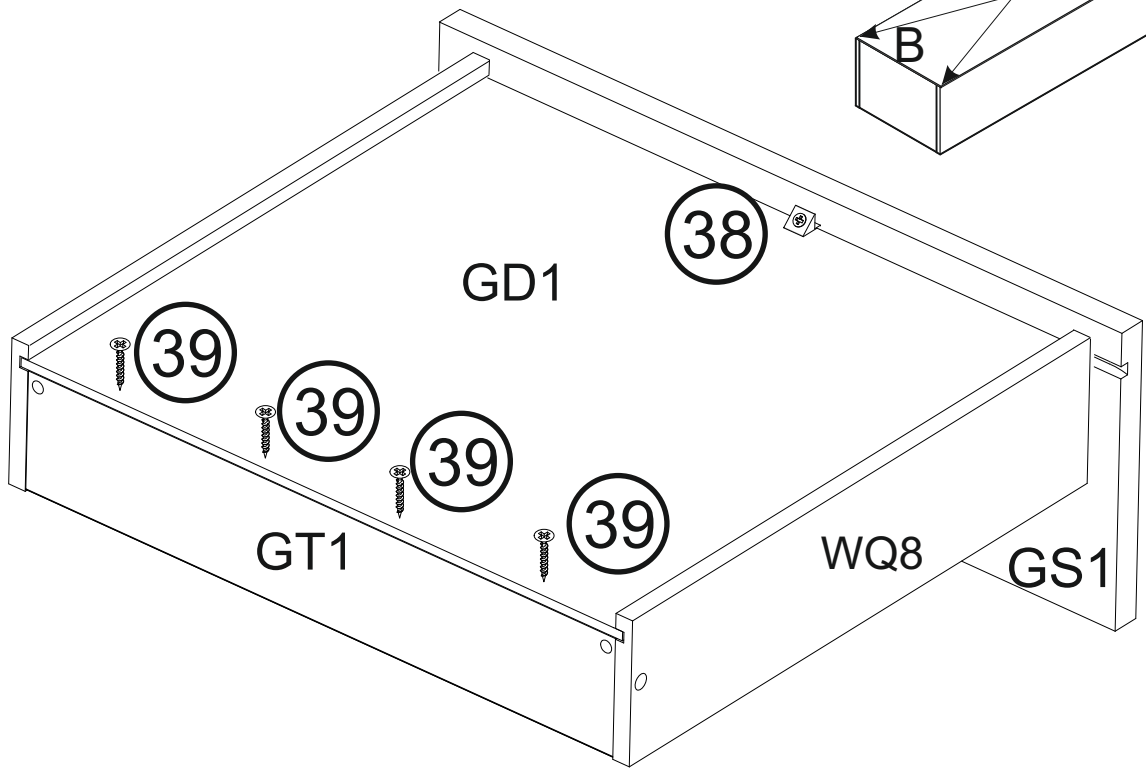
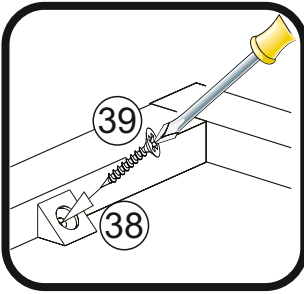
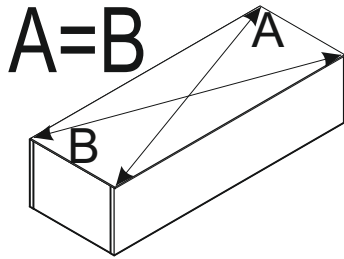
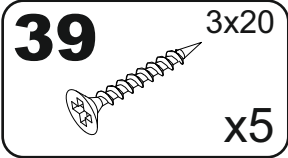
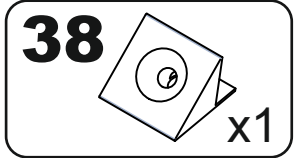

14

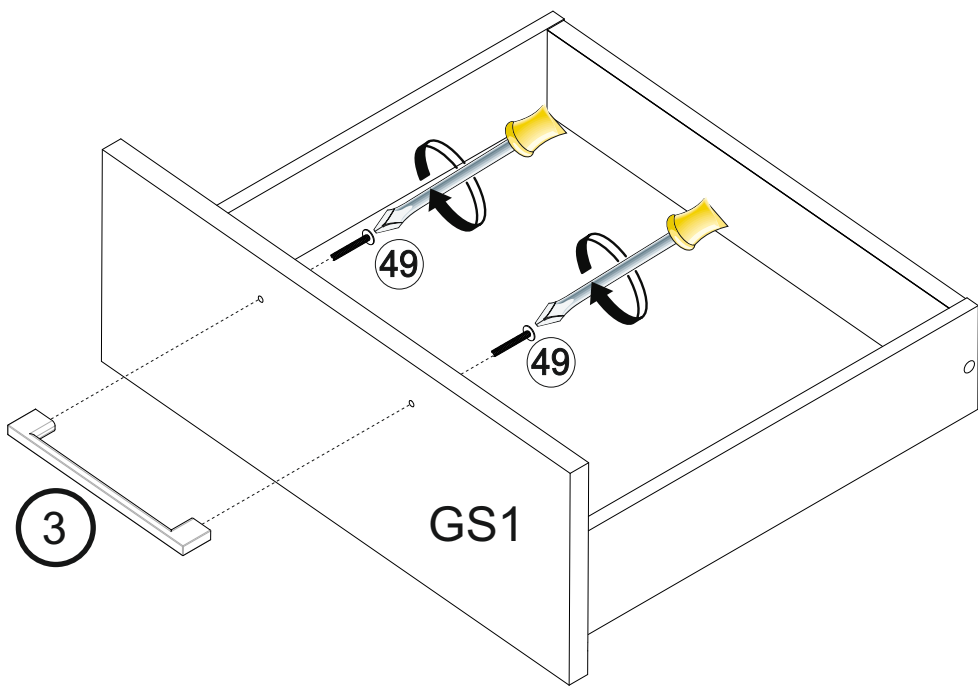
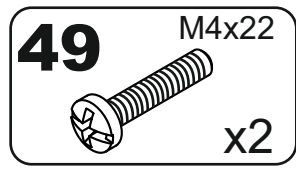
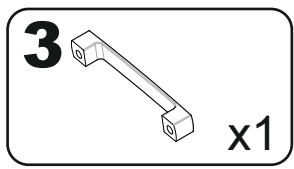

15

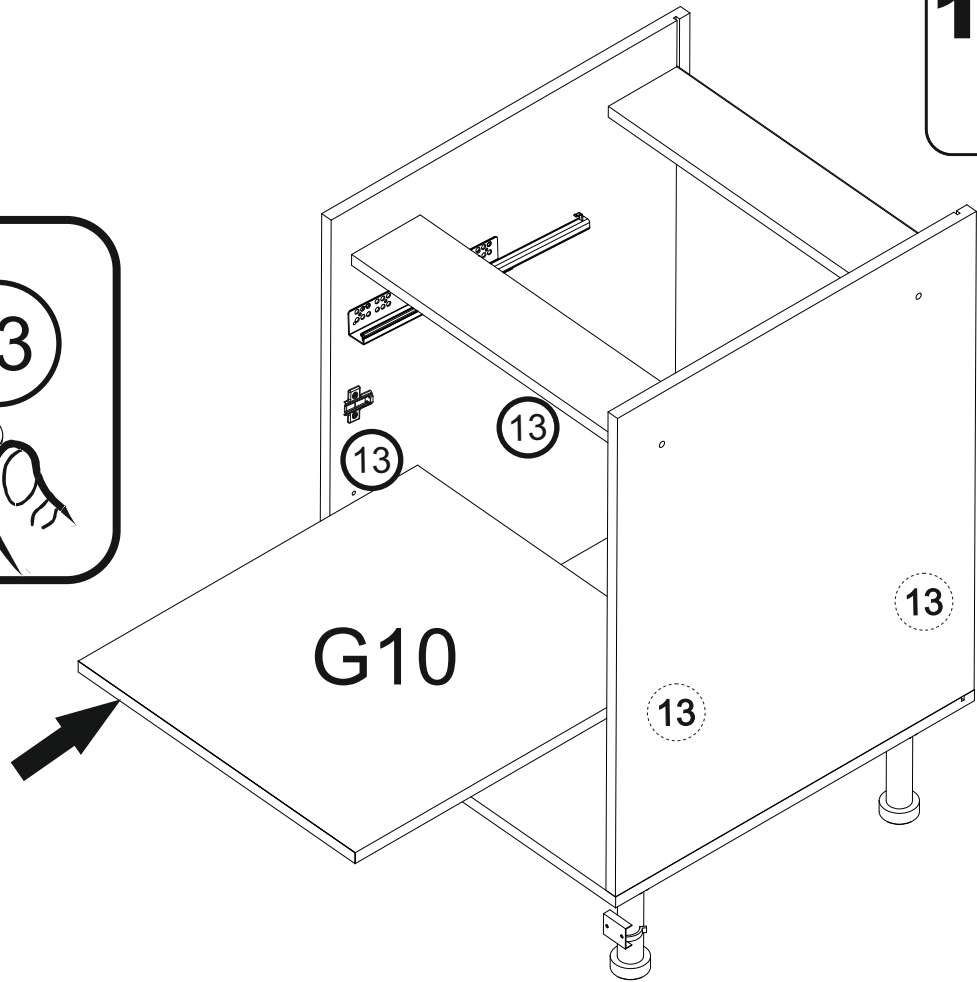
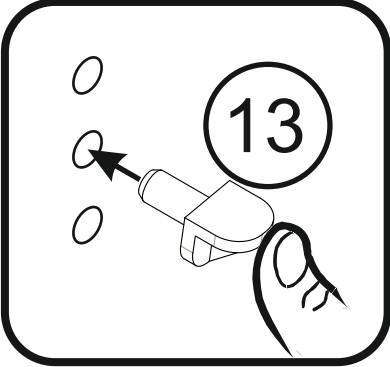
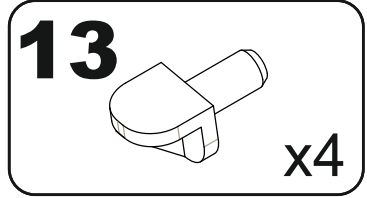

16

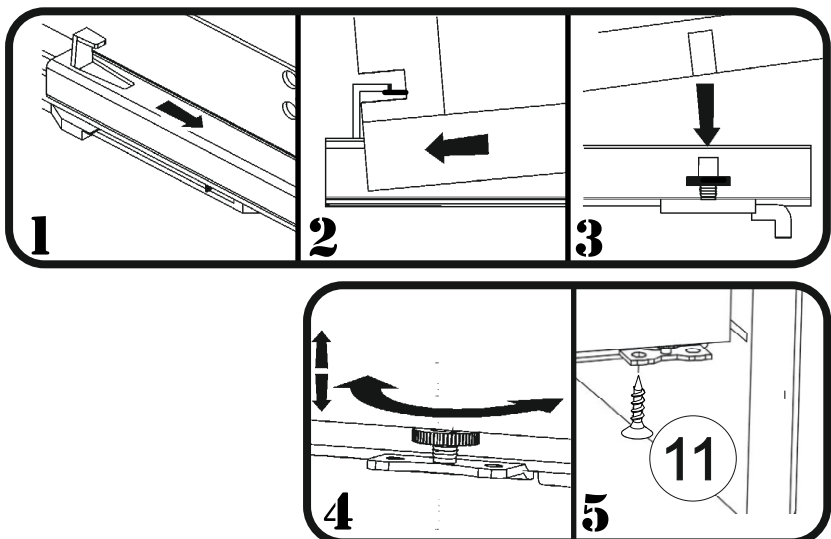
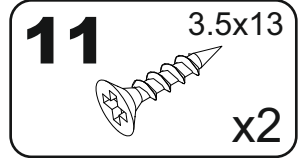

17

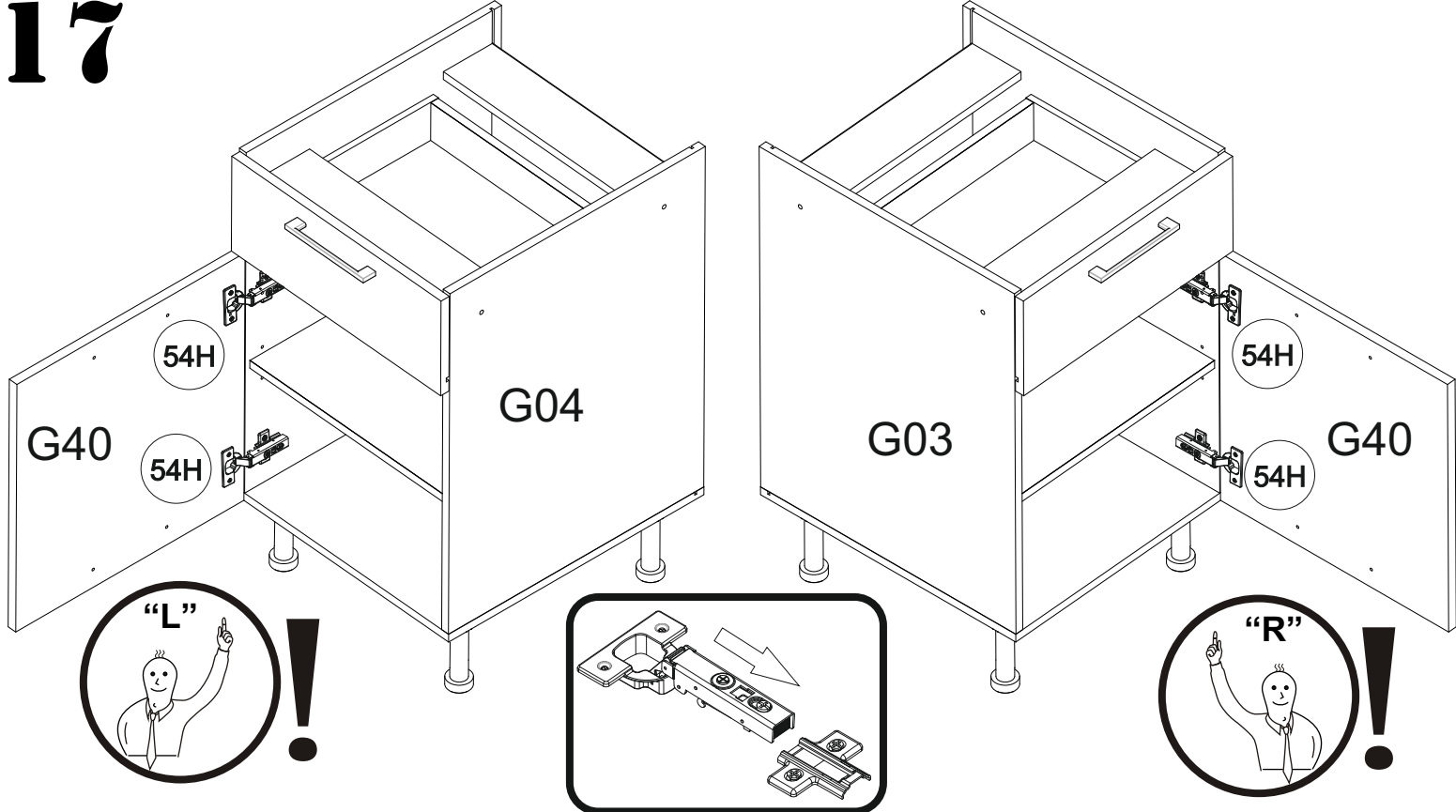

18

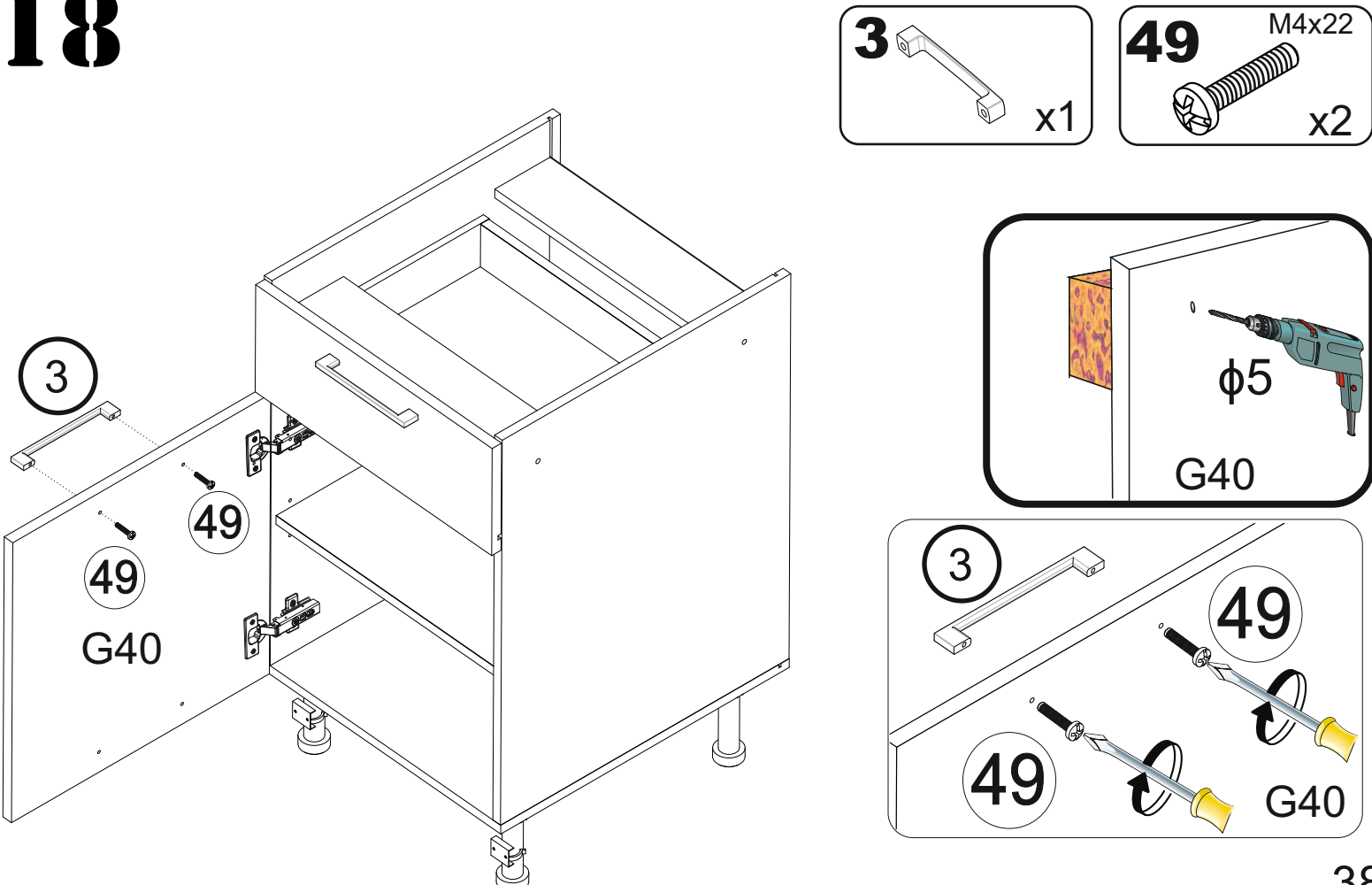

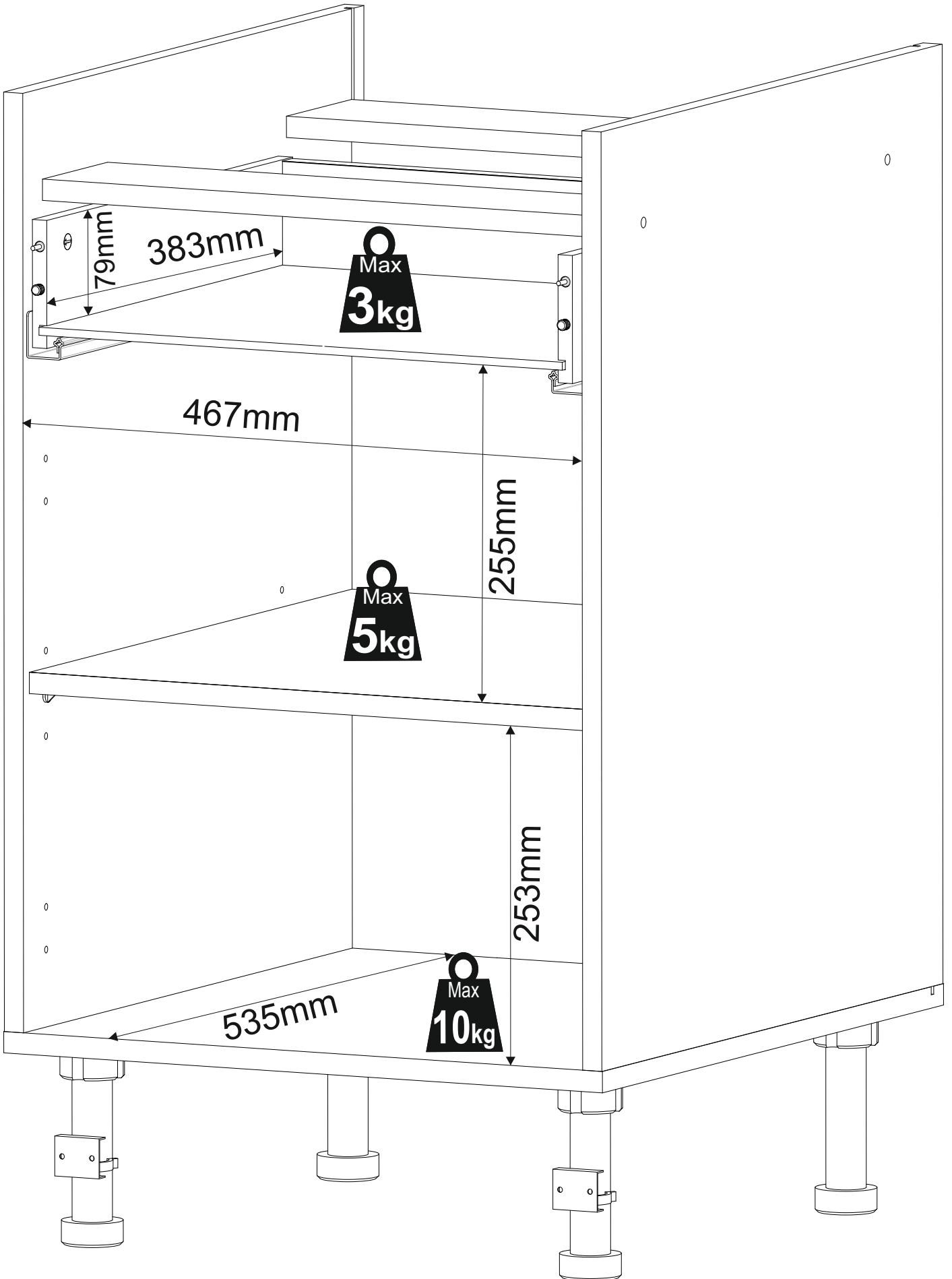
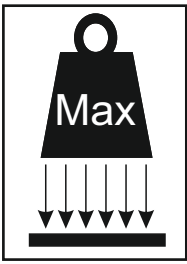

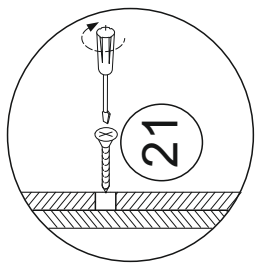
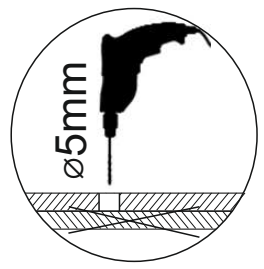
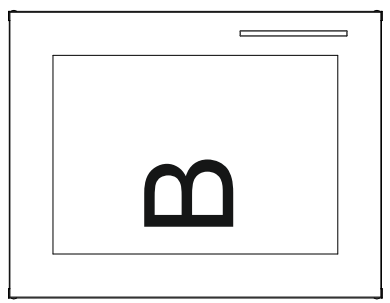
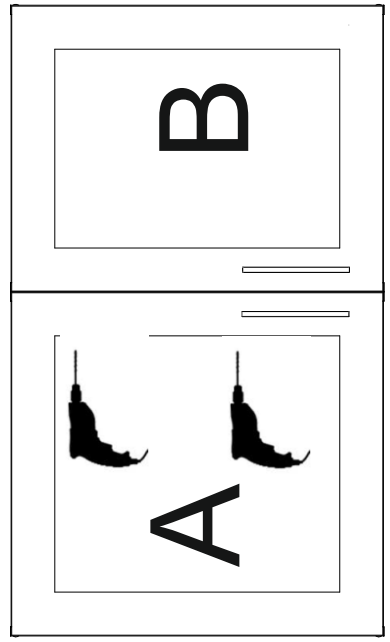
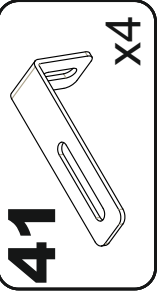
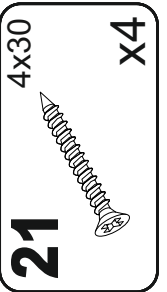
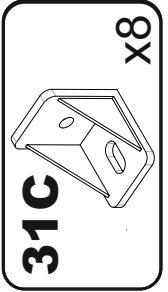
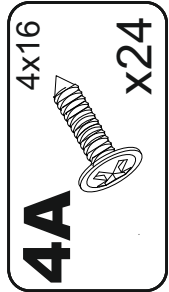

Z01

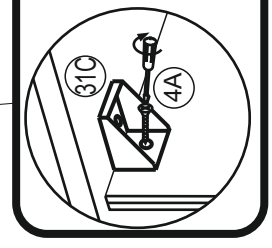
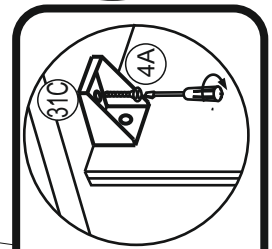
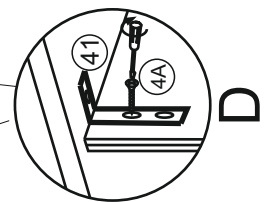
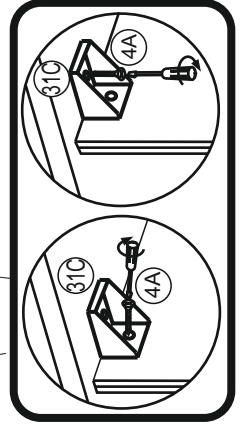
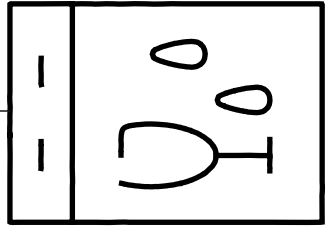
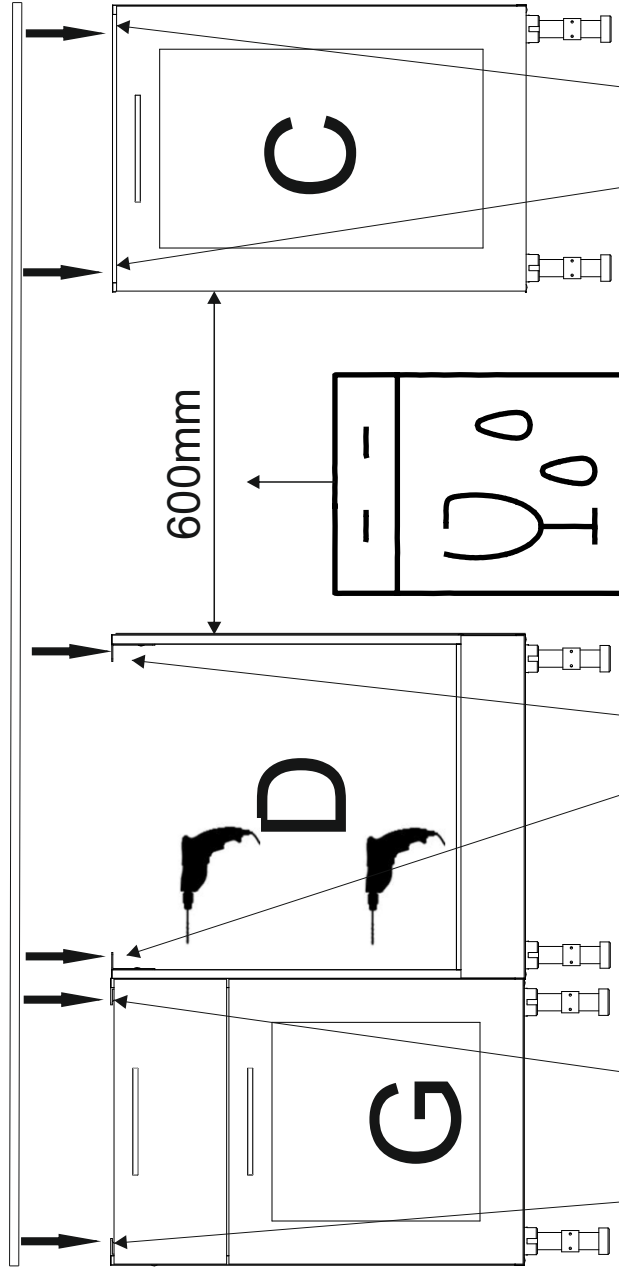

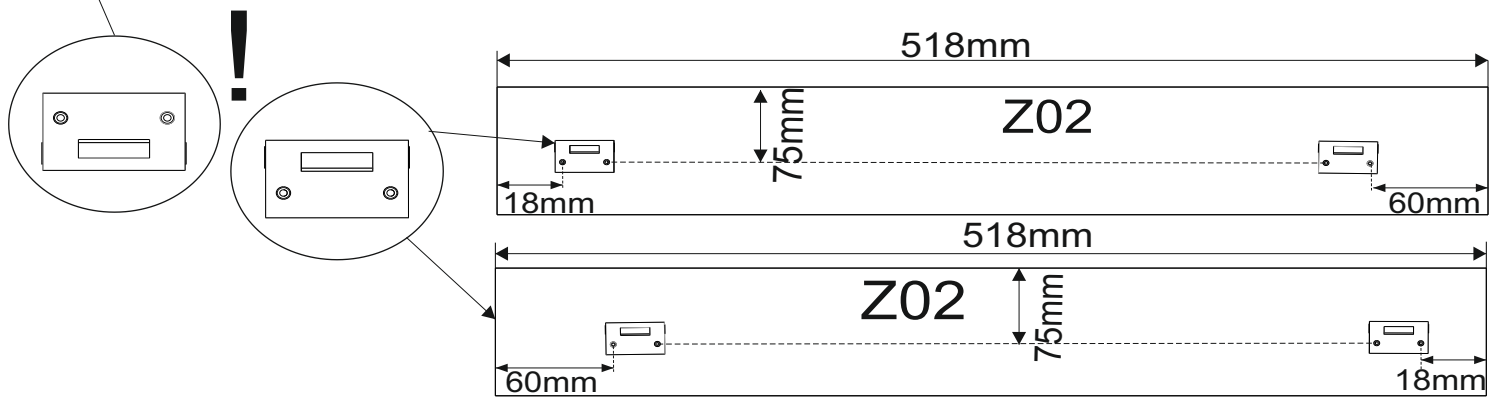
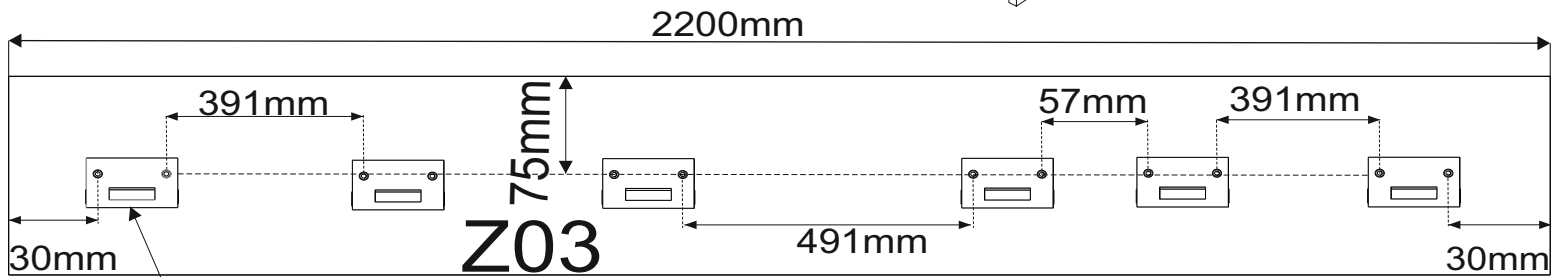
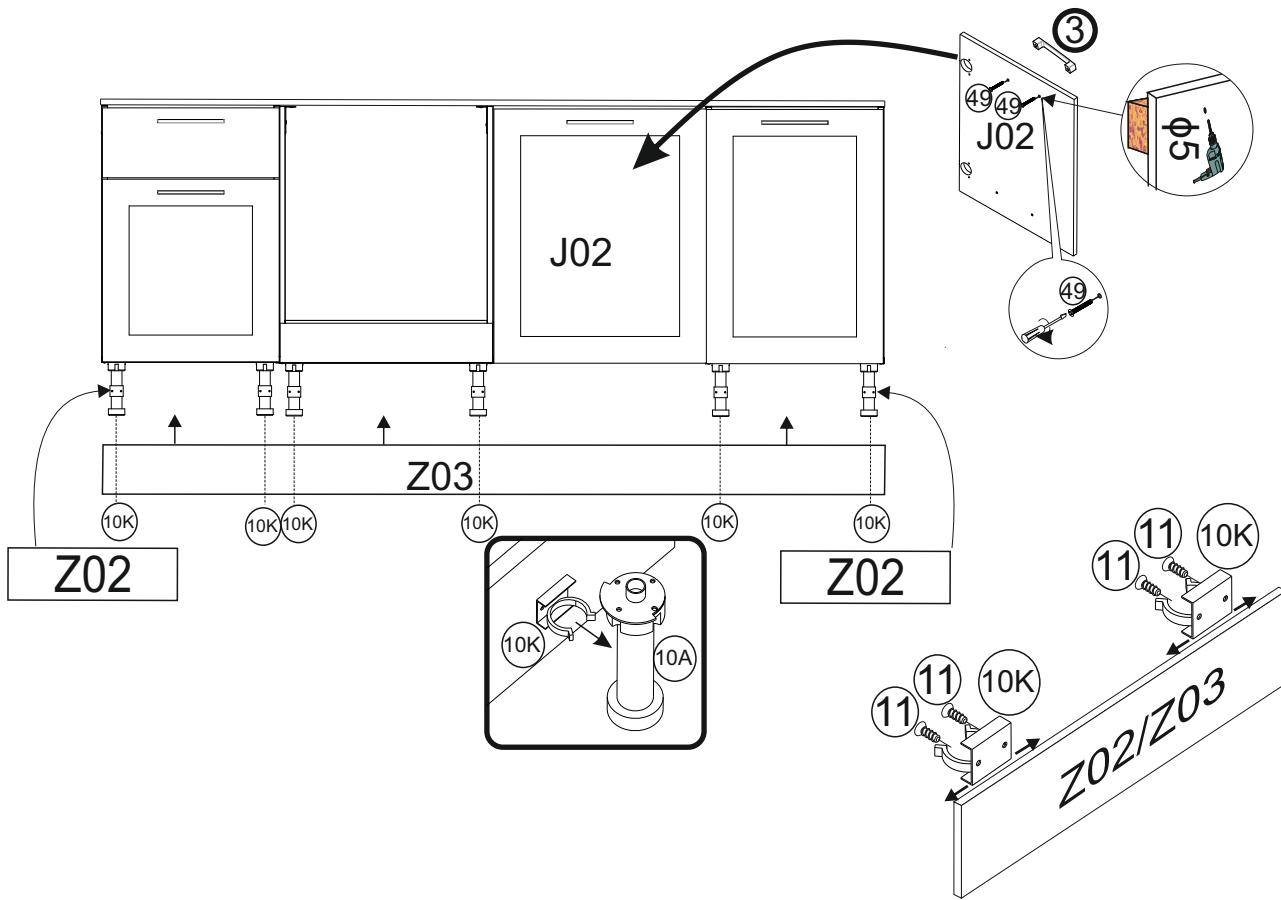
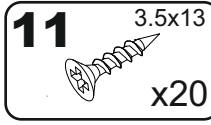
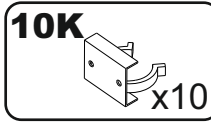
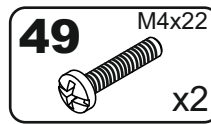
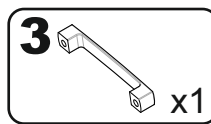
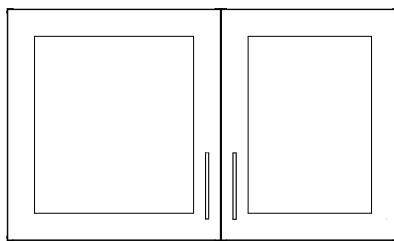
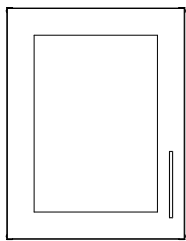

A	B_(mm)	C_(mm)	D_(mm)	E	F
Z01	2202	600	28	1	6 6
Z02	518	150	16	2	6 6
Z03	2200	150	16	1	6 6
J02	713	596	18	1	5 6

Erst wenn alles exakt steht, verbinden Sie die einzelnen Schränke mit Schrauben. Damit dabei nichts verrutscht, empfehlen wir Ihnen dringend den Einsatz von zwei Schraubzwingen. Die Schrankoberflächen schützen Sie mit Zulagehölzern vor Eindrücken.

Ermitteln Sie durch exaktes Messen die Positionen der Bohrungen für die Hängebeschläge

Legen Sie die Arbeitsplatte auf die Korpusse, richten Sie sie aus, und fixieren Sie sie mit Zwingen. markieren Sie die Lage und -breite des Herdunterschrankes.

Auf der Unterseite der Arbeitsplatte reißen Sie im markierten Bereich den Herdplattenausschnitt auf. Mitteln Sie sie aus, so dass die Spüle mittig im Unterschrank sitzt und vorne und hinten die Plattenrestbreite gleich wird.



Empfohlenes Vorgehen bei der Küchenmontage:

Bohren Sie in den vier Ecken jeweils ein 10-mm-Loch zum leichteren Einsetzen der Stichsäge, und schneiden Sie den Herdausschnitt entlang Ihrer Risse aus. Arbeiten Sie immer von der Plattenunterseite, damit die Plattenoberfläche durch die Stichsäge nicht ausfasert. Schalten Sie dazu auch den Pendelhub an Ihrer Stichsäge, sofern vorhanden, aus.

Zum Schutz der Holzteile können Sie rundum die Sockelteile eine Silikonnaht ziehen



Empfohlenes Vorgehen bei der Küchenmontage:

Bohren Sie in den vier Ecken jeweils ein 10-mm-Loch zum leichteren Einsetzen der Stichsäge, und schneiden Sie den Herdausschnitt entlang Ihrer Risse aus. Arbeiten Sie immer von der Plattenunterseite, damit die Plattenoberfläche durch die Stichsäge nicht ausfasert. Schalten Sie dazu auch den Pendelhub an Ihrer Stichsäge, sofern vorhanden, aus.

Zum Schutz der Holzteile können Sie rundum die Sockelteile eine Silikonnaht ziehen



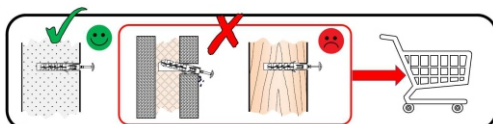
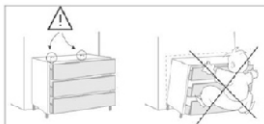

DE	<p>Warnhinweis:</p> <p>Wenn der Ware Dübel und Schrauben beiliegen, sind sie ausschließlich zur Anwendung an Wänden aus massiven und einheitlichen Materialien bestimmt, um ein Umkippen zu verhindern. Vergewissern Sie sich vor dem Bohren, dass sich keine Gas-, Wasser-, oder Stromleitungen an der Bohrstelle befinden. Zur Befestigung an anderen Wänden müssen Spezialdübel verwendet werden. Erkundigen Sie sich im Handel nach den für die jeweilige Wandbeschaffenheit geeigneten Schrauben und oder Dübel. Für eine unsachgemäße Montage und dadurch entstandene Schäden übernimmt der Hersteller keine Haftung. Bitte alle Schrauben in regelmäßigen Abständen überprüfen und nachziehen.</p>
FR	<p>Avertissement :</p> <p>Pour éviter le basculement accidentel du meuble, la fixation du meuble au mu rest obligatoire.</p> <p>Si des chevilles et des vis sont fournies avec l'article, elles sont exclusivement destinées à être utilisées sur des murs en matériaux massifs et homogènes pour éviter tout basculement. Avant de percer, assurez-vous qu'aucune conduite de gaz, d'eau ou d'électricité ne se trouve à l'endroit où vous percez. Pour la fixation sur d'autres murs, il faut utiliser des chevilles spéciales. Renseignez-vous en magasin sur les vis et les chevilles adaptées à chaque type de mur. Le fabricant décline toute responsabilité en cas de montage incorrect et de dommages qui en résulteraient. Veuillez vérifier et resserrer toutes les vis à intervalles réguliers.</p> <p>ATTENTION !</p> <p>Les meubles contenant des panneaux à base de bois (panneaux de particules, panneaux de fibres, contreplaqué...) peuvent émettre des substances polluantes dans l'air intérieur. Il est ainsi recommandé, après l'installation du meuble dans son logement, d'aérer fréquemment la pièce concernée pendant au moins quatre semaines afin de réduire son exposition aux polluants émis par le meuble</p> <p>LED:</p> <p>Ce luminaire est un produit de décoration. Ce luminaire ne convient pas pour l'éclairage principal d'une pièce de la maison.</p>
UK	<p>Warning:</p> <p>If dowels and screws are included with the product, they are only intended for use on walls made of solid and uniform materials to prevent them from tipping over. Before drilling, make sure that there are no gas, water or electricity pipes at the drilling site. Special anchors must be used for fastening to other walls. Ask in the trade for the screws and or dowels suitable for the respective wall condition. The manufacturer accepts no liability for improper installation and any resulting damage. Please check and retighten all screws at regular intervals.</p>
IT	<p>Avvertenza:</p> <p>Se con il prodotto sono forniti tasselli e viti, questi sono destinati esclusivamente all'utilizzo su pareti realizzate con materiali solidi ed uniformi, per evitare il ribaltamento. Prima di eseguire i fori assicurarsi che non ci siano condutture di gas, acqua o elettriche vicino al punto di perforazione. Per il fissaggio ad altre pareti è necessario utilizzare tasselli speciali. Chiedere al proprio rivenditore le viti e/o tasselli adatti al tipo di parete in questione. Il produttore non si assume alcuna responsabilità in caso di montaggio improprio e dei danni che ne derivano. Controllare e serrare tutte le viti a distanza regolare.</p>
PL	<p>Ostrzeżenie:</p> <p>Jeżeli do towaru dołączone są kołki i śruby, są one przeznaczone wyłącznie do stosowania na ścianach wykonanych z solidnych i jednolitych materiałów, aby zapobiec przewróceniu. Przed rozpoczęciem wiercenia należy upewnić się, że w miejscu wiercenia nie są ułożone rury gazowe, wodociągowe lub przewody elektryczne. Do mocowania do innych ścian należy stosować kołki specjalne. O śruby lub kołki odpowiednie dla konstrukcji danej ściany należy pytać w sklepach specjalistycznych. Producent nie ponosi odpowiedzialności za nieprawidłowy montaż i wyniki z tego tytułu szkody. Wszystkie śruby należy regularnie sprawdzać i dokręcać.</p>
ESP	<p>Advertencia:</p> <p>En el caso de incluirse tacos y tornillos con la mercancía, estos están previstos únicamente para su uso en paredes macizas y homogéneas a fin de evitar un posible vuelco. Antes de taladrar, asegúrese de que por el punto de perforación no pasan tuberías de gas o agua o cables eléctricos. Para la fijación en otro tipo de paredes deben utilizarse tacos especiales. Pregunte en la tienda por los tornillos o tacos adecuados para las características de la pared en cuestión. El fabricante no asume ninguna responsabilidad por un montaje incorrecto ni por los daños resultantes del mismo. Compruebe todos los tornillos en intervalos regulares y apriéte los.</p>
CZ	<p>Výstražné upozornění:</p> <p>Pokud jsou k výrobku přiloženy hmoždinky a šrouby, jsou určeny výhradně pro použití do stěn zhotovených z masivních a homogenních materiálů, a to za účelem zajištění proti převrácení. Před vrtáním se ujistěte, že se v místě vrtání nenachází vedení plynu, vody nebo elektřiny. Pro připevnění k jiným stěnám je nutné použít speciální hmoždinky. Informujte se v obchodě o hmoždinkách a/nebo šroubech vhodných pro příslušnou strukturu stěny. Výrobce nenes odpovědnost za nesprávnou montáž a za škody jí způsobené. Všechny šrouby pravidelně kontrolujte a dotahujte.</p>
SK	<p>Informácia o nebezpečenstve:</p> <p>Ak sú k tovaru priložené príchytky a skrutky, sú určené výlučne na použitie na stenách z masívnych a jednotných materiálov, aby sa zabránilo prevráteniu. Pred vrtaním sa uistite, že sa na vrtanom mieste nenachádzajú žiadne plynové, vodovodné alebo elektrické vedenia. Na upevnenie na iných stenách musia byť použité špeciálne príchytky. Spýtajte sa v predajni na skrutky a/alebo príchytky vhodné pre príslušný typ steny. Výrobca nepreberá ručenie za nesprávnu montáž a tým vzniknuté škody. Všetky skrutky v pravidelných intervaloch kontrolujte a dotiahnite.</p>
HU	<p>Figyelmeztetés:</p> <p>Amennyiben a termék csomagolásá tipliket és csavarokat is tartalmaz, azok kizárólag masszív, egységes anyagból készült falakon használhatók, a felborulás megakadályozásának céljából. A fúrás előtt bizonyosodjon meg arról, hogy a fúrás helyén nem található gáz-, víz- vagy elektromos vezeték. Egyéb falakra történő rögzítéshez speciális tiplik szükségesek. Az egyes faltípusokkal használható megfelelő csavarokkal és/vagy tiplikkal kapcsolatos információkért kérjük, forduljon forgalmazójához. A nem szakszerű szerelésért és az abból keletkező károkért a gyártót semmilyen felelősség nem terheli. Minden csavart ellenőrizzen és rögzítsen rendszeresen.</p>
BG	<p>Предупредително указание:</p> <p>Ако в окомплектовката на доставката на стоката са включени дюбели и винтове, те са предназначени единствено за употреба върху стени от масивни и еднородни материали, за да се предотврати преобръщане. Преди пробиване се уверете, че на мястото на пробиване няма тръби за газ, за вода или електрически проводници. За закрепване към други стени трябва да се използват специални дюбели. Информирайте се в търговската мрежа относно подходящите винтове и/или дюбели за съответната конструкция на стената. Производителят не поема отговорност за неправилен монтаж и възникнали в резултат на това щети. Моля, проверявайте и затягвайте всички винтове на редовни интервали.</p>
TR	<p>Uyarı:</p> <p>Ürün paketinde dübel ve vida varsa, bunlar devrilmeyi önlemek amacıyla, sadece masif ve yekpare malzemelerden imal edilmiş duvarlardaki kullanım için öngörülmüştür. Matkapla delik açmadan önce delme noktasında gaz, su veya elektrik hatlarının olmadığından emin olun. Ürünü başka duvarlara sabitlemek için özel dübeller kullanılmalıdır. Piyasadaki satıcılardan ilgili duvarın özelliğine uygun vidalar ve dübeller hakkında bilgi alın. Usulüne aykırı bir montaj ve bu nedenle oluşmuş hasarlar için üretici sorumluluk almamaktadır. Lütfen tüm vidaları düzenli aralıklarla kontrol edip tekrar sıkın.</p>

PT	Advertência: Caso o produto venha com buchas e parafusos incluídos, os mesmos são exclusivamente destinados à fixação em paredes de materiais sólidos e uniformes, para evitar que o produto tombe. Antes de iniciar a perfuração, certifique-se de que não existem canalizações de gás, água ou fios elétricos a passar no local dos furos. Para a fixação noutra tipo de paredes, têm de ser utilizadas buchas especiais. Informe-se junto de um comerciante especializado sobre os parafusos e buchas a utilizar na parede específica. O fabricante não assume qualquer responsabilidade no caso de uma montagem inadequada e qualquer dano daí resultante. Verifique e volte a apertar todos os parafusos regularmente.
SI	Opozorilo: če so blagu priloženi zidni vložki in vijaki, so ti namenjeni izključno za uporabo na stenah iz masivnih in enotnih materialov, da se prepreči prevrnitev. Pred vrtnanjem se prepričajte, da na mestu vrtnanja ni plinskih, vodnih ali električnih napeljav. Za pritrditev na druge stene je treba uporabljati posebne zidne vložke. Pozanimajte se v trgovini o vijakih in/ali zidnih vložkih, primernih za posamezno sestavo stene. Proizvajalec ne prevzema jamstva za nepravilno montažo in zaradi tega nastalo škodo. Vse vijake redno preverjajte in naknadno privijajte.
NL	Waarschuwing: Indien er bij het product pluggen en schroeven zijn meegeleverd, zijn deze uitsluitend bestemd om in muren van massieve en homogene materialen te gebruiken om te voorkomen dat het product kantelt. Controleer voordat u begint of er geen gas-, water- of elektriciteitsleidingen lopen waar u gaat boren. Voor de bevestiging aan andere soorten muren moeten speciale pluggen worden gebruikt. Informeer in de winkel welke schroeven en/of pluggen geschikt zijn voor de desbetreffende muur. De fabrikant is niet aansprakelijk voor een onjuiste montage en de daardoor ontstane schade. Controleer regelmatig of alle schroeven nog goed vastzitten en draai ze zo nodig vast.
SRB	Upozoravajuća napomena: Ako su uz robu priloženi tiplovi i zavrtnji, isti su namenjeni isključivo za primenu na zidovima od kompaktnih i homogenih materijala, kako bi se sprečilo prevrtanje. Pre bušenja se uverite da se na mestu bušenja ne nalaze vodovi za gas, vodu ili struju. Za fiksiranje na drugačijim zidovima moraju da se upotrebe specijalni tiplovi. Raspitajte se u trgovini o zavrtnjima i/ili tiplovima koji su adekvatni za dotičnu teksturu zida. Proizvođač ne preuzima nikakvu odgovornost za nestručnu montažu i štete koje su nastale na taj način. Sve zavrtnje kontrolišite i dotežite u redovnim intervalima.
RO	Indicație de avertizare: Dacă produsul este livrat împreună cu șuruburi și dibluri, acestea sunt destinate exclusiv utilizării pe pereții construiți din materiale masive și uniforme, pentru a preveni răsturnarea produsului. Înainte de a realiza găurile, asigurați-vă că nu există conducte de gaz, apă sau electricitate în locul pe care doriți să-l găuriți. Pentru prinderea pe alte tipuri de pereți, trebuie să utilizați dibluri speciale. Interesați-vă la magazinul specializat, pentru a găsi șuruburile și/sau diblurile potrivite pentru peretele dvs. Producătorul nu este responsabil, în cazul unui montaj necorespunzător pentru daunele rezultate. Vă rugăm să verificați toate șuruburile la intervale regulate și să le strângeți.
HR	Upozorenje: Ako su uz proizvod priložene tiplje i vijci, oni su namijenjeni isključivo za korištenje na zidovima od čvrstih i jednoličnih materijala kako bi se spriječilo prevrtanje. Prije bušenja provjerite da na mjestu bušenja nema električnih vodova, plinskih ili vodovodnih cijevi. Za pričvršćivanje na ostale zidove potrebno je koristiti posebne tiplje. Prilikom kupnje raspitajte se kod svog prodavača o vijcima i tiplama koji su prikladni za odgovarajuću zidnu strukturu. Proizvođač ne odgovara za štete nastale uslijed nepravilne montaže. Sve vijke potrebno je redovito provjeravati i zategnuti.
SE	Varning: Om plugg och skruvar följer med produkten är de endast avsedda för väggar av massivt och enhetligt material för att förhindra att produkten vippas. Försäkra dig om att inga gas-, vatten- eller elledningar befinner sig på platsen som du ska borra innan du börjar. För fastsättning i väggen måste specialplugg användas. Informera dig i en butik om vilka skruvar och plugg som passar till vilken vägg. För en felaktig montering och skador som uppstår på grund av detta tar tillverkaren inget ansvar. Kontrollera och dra åt alla skruvar med jämna mellanrum.
RUS	Предупреждение: Если изделие поставляется вместе с дюбелями и шурупам, они предназначены исключительно для использования на стенах из монолитных и однородных материалов, чтобы предотвратить возможное обрушение. Перед началом сверления убедитесь, что на месте сверления нет газопровода, водопровода или электропроводки. Для крепления к другим стенам необходимо использовать специальные дюбели. Узнайте у продавца, какие шурупы или дюбели подходят для соответствующей структуры стены. Производитель не несет ответственности за неправильный монтаж и вызванный им ущерб. Регулярно проверяйте и подтягивайте все шурупы.
UKR	Попередження: Якщо до виробу додаються дюбелі та гвинти, вони призначені виключно для використання на стінах з цільних й однорідних матеріалів, щоб не допустити перекидання. Перед свердлінням переконайтеся, що на місці свердління немає ліній газо-, водопостачання чи електропроводки. Для кріплення до інших стін необхідно використовувати спеціальні дюбелі. Запитайте продавця, які гвинти та/або дюбелі підходять для стіни з відповідною структурою. Виробник не несе відповідальності за неправильний монтаж та збитки, що виникли внаслідок цього. Перевіряйте та підтягуйте всі гвинти через регулярні проміжки часу.
LT	Įspėjimas: jei prie prekės pridėtos mūrvinės ir varžtai, jie skirti naudoti tik ant sienų, pagamintų iš tvirtų ir vienodų medžiagų, kad būtų galima išvengti apvirtimo. Prieš gręždami įsitinkite, kad gręžiamoje vietoje nėra dujotiekio, vandentiekio ar elektros linijų. Tvirtinant prie kito tipo sienų reikia naudoti specialias mūrvines. Teiraukitės pardavėjo atitinkamai sienos konstrukcijai tinkamų varžtų ir (arba) mūrvinių. Gamintojas nepriima atsakomybės dėl netinkamo montavimo ir dėl to atsiradusios žalos. Visus varžtus reguliariai tikrinkite ir priveržkite.
LV	Brīdinājums: Ja prece ir pievienoti dībeļi un skrūves, prece ir paredzēta izmantošanai tikai uz sienām, kas izgatavotas no cietiem un viendabīgiem materiāliem, lai novērstu apgāšanos. Pirms urbšanas pārlicinieties, ka urbšanas vietā nav gāzes, ūdens vai elektropārvades līniju. Lai piestiprinātu pie citām sienām, jāizmanto speciāli dībeļi. Jautājiet savam izplatītājam par skrūvēm un/vai dībeļiem, kas ir piemēroti attiecīgajai sienas konstrukcijai. Ražotājs neuzņemas atbildību par nepareizu montāžu un no tās sekojošajiem bojājumiem. Lūdzu, regulāri pārbaudiet un pievelciet visas skrūves.
EE	Hoiatus! Kui tootele on kaasa pandud tüüblid ja kruvid, on need mõeldud kasutamiseks üksnes massiivsest ja ühtsest materjalist seintel, vältimaks ümberkukkumist. Veenduge enne puurimist, et puurimiskohas ei oleks gaasi- või veetorusid ega elektrijuhtmeid. Seintele kinnitamiseks tuleb kasutada spetsiaalseid tüüpleid. Uurige kaubandusvõrgust, millised kruvid ja/või tüüblid konkreetse seina jaoks sobivad. Tootja ei võta endale mittenõuetekohasest paigaldamisest tingitud kahjude eest mingit vastutust. Kontrollige ja järelpingutage kõiki kruvisid regulaarselt.



INFO RECYCLAGE:

<https://quefairedemesdechets.fr>